



TECHNICAL REPORT

# STATE OF THE ART: CCS TECHNOLOGIES 2022



GLOBAL CCS  
INSTITUTE

NOUMAN MIRZA, Ph.D  
Consultant - CCS Technologies

DAVID KEARNS, Ph.D  
Principal Consultant - CCS Technologies



# CONTENTS

FOREWORD	4
CAPTURE	6
AIR LIQUIDE	8
AIR PRODUCTS	16
AKER CARBON CAPTURE	20
AXENS	24
C-CAPTURE	28
CARBON ENGINEERING	32
CARBON CLEAN	34
CO2 CAPSOL	38
DECARBONTEK	42
ENTROPY	44
HONEYWELL	46
IHI	50
LEILAC GROUP (CALIX)	54
SAIPEM	56
SHELL	60
SVANTE	70
TRANSPORT	74
K-LINE	76
KNCC	78
MAN	82
SVANEHOJ	84
TORISHIMA	86
STORAGE	90
DRIL-QUIP	92
MAXTUBE	94
FULL VALUE CHAIN	98
BAKER HUGHES	102
CAPTICO2	122
CARBFIX	124
CHEVRON	128
JCCS	132
LINDE	136
NOV	148
SCHLUMBERGER	152
SICK	156





# FOREWORD

Carbon Capture and Storage (CCS) has emerged as an indispensable tool in humanity's efforts to combat climate change and reach its goal of net-zero emissions. Industries as diverse as cement, iron and steel, chemicals, natural gas and electricity generation can benefit from the ability of CCS to cut industrial CO<sub>2</sub> emissions deeply.

CCS is also moving into carbon dioxide removal (CDR) in applications such as Direct Air Capture (DAC) and Bioenergy with CCS (BECCS), drawing down historical CO<sub>2</sub> emissions from the atmosphere.

The CCS sector has been growing at an unprecedented rate in recent years, and that growth is only accelerating. The increased dependence of global plans for net-zero on CCS means that the economic performance of CCS is becoming increasingly important.

Technology development will be a significant driver of improved economics for CCS. Higher energy efficiency, reduced variable operating costs, capital cost reductions, and plant performance improvements, enabled by new technologies, are meeting the demand for improved CO<sub>2</sub> capture system performance, transport system costs, and CO<sub>2</sub> storage options.

CCS is happening now, and the technology is ready to purchase today. This inaugural Technology Compendium is intended to showcase the breadth and depth of commercially-available CCS technologies worldwide. Contributions to this Compendium have come from some of the world's most prominent technology providers, as well as promising emerging firms.

David T. Kearns, PhD.  
Principal – CCS Technologies  
Global CCS Institute

May 2022

## Acknowledgements

We are grateful for the contributions and support of all the technology companies who have contributed to this publication.

Thank you to Dr Nouman Mirza for his invaluable editing and coordination of this report.

Special mentions also go to Bruno Gerrits, Christina Staib, Erin Billeri, Yasuo Murakami and Kazuko Miyashita of the Global CCS Institute for their efforts and support.





# CAPTURE







## SUMMARY

Air Liquide Engineering & Construction (Air Liquide E&C) also engineers solvent-based technologies such as amine to capture CO<sub>2</sub> from synthesis gas or flue gas. Through long term partnerships with the key amine license providers, Air Liquide has installed 80+ units and benefits from its long-term operational experience of amine units.

Considered as the industrial base case, amine technology can deliver high purity gaseous CO<sub>2</sub> (99+%) at low pressure,

which can be combined with Cryocap™ XLL. For CO<sub>2</sub> capture on flue gases with low CO<sub>2</sub> concentration (below 10%), amine technology remains the most competitive solution, provided the availability of large amounts of excess steam or high grade heat. Air Liquide Engineering & Construction is also offering proprietary technologies for CO<sub>2</sub> capture from synthesis gas (Rectisol, Recticap).

## BENEFITS

- Fully referenced in all applicable scales and different applications
- Process uses inexpensive, available and chemically stable solvent
- Technology provides low operating costs and high availability
- Process configuration can be tailored to optimize CapEx and OpEx

## DESCRIPTION

### Acid Gas Removal – Amine Wash

The process configuration and solvent selection will be tailored according to feedstock and sweet gas application. Air Liquide E&C can offer very energy-efficient processes such as the BASF OASE® purple or OASE® yellow as well as other proprietary or generic amines for pipeline or liquefied natural gas specifications. This process presents the advantage of very low hydrocarbon co-absorption. With selective processes, deep H<sub>2</sub>S removal with low to moderate CO<sub>2</sub> co-absorption can be achieved for pipeline specifications. Capacity is up to 1,500,000 Nm<sup>3</sup>/h per train.

### CO<sub>2</sub> Removal from Flue Gas (3-25% CO<sub>2</sub>) - Amine Wash

Trace components such as particles and SO<sub>x</sub> are handled in the upstream pretreatment. Air Liquide offers energy efficient solutions with highly stable, low maintenance solvents based on proprietary second-generation amines. CO<sub>2</sub> capture rates of up to 95% can be reached irrespective of the feed's CO<sub>2</sub> content, and CO<sub>2</sub> product specifications of up to >99.9%. Capacities are up to 1,500,000 Nm<sup>3</sup>/h feed per train, and up to 4,000 tpd CO<sub>2</sub> per train.

### CO<sub>2</sub> Removal from Syngas - Amine Wash

Air Liquide E&C offers very energy-efficient processes such as BASF OASE® white. The process configuration will be tailored according to treated gas requirements and CO<sub>2</sub> product specification as well as optimized CapEx and OpEx. The process can be heat-integrated with the upstream gas generation. CO<sub>2</sub> specifications in the treated gas of < 20 ppm are achievable, making this process ideal for CO<sub>2</sub> removal upstream of any coldbox or ammonia process. CO<sub>2</sub> capture rates from syngas of >99% can be achieved to produce a decarbonized hydrogen product. Since the process has a very low co-absorption even at higher feed gas pressures, CO<sub>2</sub> product specifications with CO<sub>2</sub> > 99% are achievable.

### Rectisol™

Harmful acid gases contained in raw gases from any gasification are removed by absorption with a physical solvent (cold methanol). Rectisol™ is the leading process when it comes to the purification of gasification-based syngas for catalytic applications (production of SNG, methanol, ammonia, or Fischer-Tropsch) as well as hydrogen and syngas for power production. Using inexpensive solvent in combination with optimized heat integration, the Rectisol™ process has extremely low operating costs and high availability.

### Key Figures

- 50,000 - 1,000,000 Nm<sup>3</sup>/hr per train (feed gas)
- Special setups for removal of mercaptans, metal carbonyls and BTX available
- Accumulation of all harmful contaminants within the acid gas to be safely processed in an SRU

### Recticap™

Recticap™ is AL-Lurgi's Rectisol™ tailored for carbon capture from natural gas reforming to produce low-cost blue hydrogen in large capacities (>300,000 kNm<sup>3</sup>/hr) at moderate to high pressures (>25 bar). In contrast to a Rectisol™, Recticap™ removes only CO<sub>2</sub> from the raw hydrogen/syngas and has a simplified process setup with reduced capital expenditures. The solution allows up to >95% CO<sub>2</sub> capture from syngas. Dry CO<sub>2</sub> capture-ready at >98.5% purity is achievable.





## SUMMARY

Air Liquide Engineering and Construction has developed Cryocap™ XLL, which is specifically designed to liquefy large volumes of CO<sub>2</sub>. The solution allows aggregation of CO<sub>2</sub> from various emitters utilizing possibly different types of carbon capture technologies. On top of liquefying CO<sub>2</sub>, Cryocap™ XLL also allows the removal of moisture and other compounds (such as O<sub>2</sub>) to meet CO<sub>2</sub> sink specifications. The technology has been developed for large scale and is able to reduce specific power for CO<sub>2</sub> liquefaction by 40% compared to existing small scale CO<sub>2</sub> liquefier used for industrial merchant application.

The technology is especially suited for CO<sub>2</sub> industrial hubs and basins where the CO<sub>2</sub> needs to be transported via ships, trucks, or trains. Cryocap™ XLL is a HSE-friendly solution that does not involve the use of any toxic or flammable external refrigerant (such as ammonia or propane). As a single compressor is used for both the feed and the cycle, it is also a very compact and cost-effective solution.

## BENEFITS

- HSE-Friendly
- Custom plant: flexible design
- Moisture and other light compounds (O<sub>2</sub>, N<sub>2</sub>...) removal
- High compactness
- Low specific energy
- Cost efficiency

## DESCRIPTION

The Cryocap™ XLL process is proposed as an industrial solution to compress, liquefy, and purify the raw CO<sub>2</sub> stream resulting from upstream units. The CO<sub>2</sub> feed gas is compressed in the feed/recycle compressor, dried at an intermediate pressure and then compressed again. The compressed gas is cooled down and then routed to the cold process. In the cold process, the high-pressure, dry CO<sub>2</sub> is cooled down and split into various streams. One of these streams is purified by distillation in the Stripping Column to produce liquid CO<sub>2</sub> product, which is routed to the unit's battery limits. The remaining streams are expanded to different levels and vaporized in the main heat exchanger, providing the refrigeration load required for the liquefaction of CO<sub>2</sub>. Once vaporized, these streams are recycled at ambient temperature to the feed/recycle compressor. This configuration makes it possible to handle the compression of the feed gas and the refrigeration with a single compressor (so called self-refrigerated cycle).

## Key Figures

- 800 to 10,000+ tpd
- Custom plant: flexible design
- Liquefies CO<sub>2</sub> at ambient temperature
- 5-25€/t CO<sub>2</sub> liquefied
- Very low OpEx: 30-130 kWh/t CO<sub>2</sub>
- HSE-friendly (CO<sub>2</sub> cycle)

## Reference Examples

- 2020 - Industrial FEED for 7000 tpd in Belgium (Antwerp@C)







## SUMMARY

Air Liquide has been designing gas separation technologies for more than 100 years, and has leveraged its industrial demonstration units on power plants, steel blast furnaces, and H<sub>2</sub> production plants to develop the Cryocap™ product line. Cryocap™ is a proprietary technological innovation for CO<sub>2</sub> capture that is unique in the world, and uses a cryogenic process (involving low temperatures to separate gases). Cryocap™ can be adapted to specific applications combining a variety of Air Liquide technologies. Customers can reduce their CO<sub>2</sub> emissions by up to 98% and have the possibility to valorise other molecules contained in the feed gas (e.g. CO and H<sub>2</sub>). Cryocap™ technology is the most environment-friendly technology and available to service customers looking to reduce the carbon footprint of their production facilities.

Driven by innovation and the need to decarbonize carbon intensive processes, Cryocap™ reference examples date back to 2005 and the product line has since been selected for multiple engineering studies, pre-Front End Engineering & Design (pre-FEED), FEED, and implementation across four continents for a diverse set of industries. To further showcase its innovative and efficient design in CO<sub>2</sub> capture, Cryocap™ has resulted in several patent filings, has been awarded by the 2021 EU Innovation Fund through several projects, and has also been selected for FEED study by US DOE for industrial capture projects.

Our portfolio of cryogenic technologies includes:

- Cryocap™ H<sub>2</sub> for hydrogen production: Steam Methane Reformer (SMR), AutoThermal Reforming (ATR), or Partial Oxidation (POX)
- Cryocap™ FG for flue gases (optimal: >15% CO<sub>2</sub> dry basis)
- Cryocap™ Oxy for oxy combustion
- Cryocap™ Steel for steel production
- Cryocap™ NG for acid natural gas fields

The first industrial deployment of this technology was made in Port-Jerome, France (Cryocap™ H<sub>2</sub>), at the largest SMR Hydrogen production unit operated by Air Liquide. Since its startup in H1 2015, the plant has proven a highly reliable operation with zero impact on SMR availability, and captures 0.1 Mtpa CO<sub>2</sub> from an existing SMR while boosting H<sub>2</sub> production. Moreover, 300 tpd of liquid CO<sub>2</sub> is produced at food grade quality and sold on the market primarily for the beverage industry. Port Jerome is one of the 4 sites in Europe able to produce Hydrogen certified low carbon. It has been integrated as a pilot site for the project "CertifHy", the first Guarantee of Origin (GO) platform for green and low-carbon hydrogen.

Air Liquide Engineering & Construction (E&C) has always been committed to innovation by improving its vast portfolio of patented technologies and customized

solutions to meet and exceed customer expectations in terms of efficiency, safety, reliability and competitiveness to achieve energy transition goals. As a top technology provider with a longstanding experience in Engineering, Procurement, and Construction (EPC), we cover the entire

project life-cycle: license engineering services/proprietary equipment, high-end engineering & design capabilities, and project management & execution services. In addition, we also offer efficient customer services through our worldwide set-up.

## BENEFITS

The entire Cryocap™ suite was designed to address the challenges experienced from traditional capture solutions. Our customers value the following Cryocap™ features:

- **Minimizes overall carbon footprint:** the technologies run mainly on electricity (negligible steam), which maximizes the CO<sub>2</sub> avoided by reduced indirect CO<sub>2</sub> emissions, high CO<sub>2</sub> recovery (90 - 95%, and up to 98% with Cryocap™ Oxy and Cryocap™ H<sub>2</sub>)
- **High intrinsic process efficiency:** the technology bricks are used within their optimum range
- **Safety and environment-friendly:** solvent-free, and no toxic or flammable gases used

- **Match the end specifications:** all Cryocap™ produce either high pressure gaseous or liquid CO<sub>2</sub> at marginal extra cost and can meet the most stringent CO<sub>2</sub> specifications (up to 99.9% purity)
- **Favour synergies and optimize space:** 1-step capture and liquefaction for any stream containing >15% CO<sub>2</sub> (dry basis), very compact solutions with flexible layout configuration and simplified infrastructure compared to steam-based solutions
- **Improve productivity:** for some applications (H<sub>2</sub> and steel), installing our product improves the efficiency of the original process or enable the co-production of valuable molecules (e.g. Cryocap™ H<sub>2</sub> increases H<sub>2</sub> production by 20%)



## DESCRIPTION

### Cryocap™ H<sub>2</sub>

Based on its extensive experience in hydrogen production units, Air Liquide E&C has developed a technology capable of capturing the CO<sub>2</sub> emitted during hydrogen production (by SMR or ATR or POX). This proprietary technology is the subject of several patents and allows our customers to make significant cost reductions. On top of capturing and liquefying the CO<sub>2</sub> in one step, it is the only technology that can reduce CO<sub>2</sub> emissions during the production process while boosting hydrogen production by 13 - 20%. It has the lowest cost on the market for CO<sub>2</sub> capture in hydrogen production

units (especially compared to activated MDEA), and can be adapted to existing and future hydrogen production units.

The technology uses cryogenic purification to separate CO<sub>2</sub> from Pressure Swing Adsorption (PSA) offgas, containing typically 40-50 vol.% CO<sub>2</sub>. The PSA offgas is compressed, dried and sent to a cryogenic unit, where the CO<sub>2</sub> is separated from the other components by a combination of partial condensation and distillation. A pure and pressurized CO<sub>2</sub> flow is produced from the cold process. The non-condensed gases are recycled through a membrane system to recover H<sub>2</sub> and CO<sub>2</sub>. Residual gas



**DESCRIPTION CONT.**

is sent to the burners of H<sub>2</sub> production plant. The CO<sub>2</sub> product is compressed up to supercritical pressure or liquefied and stored in liquid storage. Liquid CO<sub>2</sub> can also be directly withdrawn from the cold process at marginal costs. The CO<sub>2</sub> can be then liquefied and purified to be used and meet CO<sub>2</sub> specifications of local industrial markets (agri-food and water treatment etc.). Cryocap™ H<sub>2</sub> can be installed for greenfield and brownfield H<sub>2</sub> plants.

**Key Figures**

- Capacity: 300 - 5,000 tpd
- Hydrogen production: increase of 13 - 20%
- Avoided CO<sub>2</sub> cost reduction: up to 40% compared to MDEA
- OpEx + CapEx: - 30-50 €/tCO<sub>2</sub> captured
- Gaseous or liquid CO<sub>2</sub>
- More than 98% of CO<sub>2</sub> recovery from syngas

**Main Applications**

- H<sub>2</sub> production (SMR or ATR)

**Reference Examples**

- 2012 - Industrial CCU EPC for 300 tpd in France
- 2019 - Industrial CCS pre-FEED in EU (Air Liquide SMR)
- 2020 - Industrial CCS FEED in Belgium (Air Liquide SMR)

**Cryocap™ FG**

Air Liquide developed a dedicated capture technology in order to address low-hanging fruits of high-concentrated sources: industrial flue gases. Many high CO<sub>2</sub>-emitting industries have concentrated sources of CO<sub>2</sub> emissions of above 15%, such as hydrogen production with SMR, cement and lime production, blast furnaces in hot metal production, and FCC in refineries. These high-concentrated sources are estimated to represent around 50% of the global industrial direct emissions. Additionally, Cryocap™ FG is not only a CO<sub>2</sub> capture technology, but can also significantly abate NO<sub>x</sub> emissions from flue gas and deliver on-spec liquid CO<sub>2</sub> product at its battery limits, thereby reducing the number of process units and interfaces, and increasing the level of overall optimization and reliability.

Cryocap™ FG is a separation process based on the combination of adsorption and cryogenic separation. The flue gas is first compressed, dried and sent to a PSA (Pressure Swing Adsorption). The PSA pre-concentrates the CO<sub>2</sub> in the offgas.

It is compressed and then sent to a cold process. There, the CO<sub>2</sub> is recovered by the combination of partial condensation and distillation, which allow the removal of various elements such as O<sub>2</sub>, Ar, N<sub>2</sub>, NO and CO. The CO<sub>2</sub> product is compressed, condensed and pumped up to supercritical pressure or directly produced as liquid. The pressurized nitrogen from the PSA is expanded to recover energy.

**Key Figures**

- Capacity: 300 – 10,000 tpd
- PSA-assisted CO<sub>2</sub> condensation
- Compressors, PSA and cryo process can be located in two different plots
- Smart impurities management (high NO<sub>x</sub>)
- 40 to 80 €/tCO<sub>2</sub> captured
- Gaseous or liquid CO<sub>2</sub>
- CO<sub>2</sub> capture rate: up to 95%

**Main Applications**

- Flue gases or off gases with CO<sub>2</sub> content ≥ 15% (SMR, cement/lime, steel blast furnace, refineries (FCC), coal/ biomass power plant, pulp & paper)

**Reference Examples**

- 2020 - Industrial CCS Engineering Study for 2,000 tpd in EU (FCC)
- 2021 - Industrial CCS Process Design Package + License for 2400 tpd in EU (Zeeland Refinery - SMR)
- 2021 - Selection by US DOE for a FEED on Holcim St Genevieve plant in US (e.g. 10,000 tpd CO<sub>2</sub>)

**Cryocap™ Oxy**

Cryocap™ Oxy uses oxy-fuel combustion exhaust as a feedstock. Its unique technological bricks include flue gas drying, dust filtration, and cryogenic purification. Through this technology, a high rate of CO<sub>2</sub> recovery is achieved, and can reduce atmospheric emissions from power plants to almost zero (emissions of NO<sub>x</sub>, SO<sub>x</sub>, fine particles and Hg). Cryocap™ Oxy is in the process of several patent filings.

The flue gas issued from the cement or lime or power plant is first treated in a pre-treatment unit, which aims to cool the gas and remove SO<sub>x</sub>, HF, HCl, most of the NO<sub>x</sub>, and dust. Then, the gas is compressed and dried before entering the cryogenic purification unit. In the cold process, CO<sub>2</sub> is recovered by a combination of partial condensation and

distillation, which allows the removal of heavy compounds such as NO<sub>x</sub> and various light elements such as O<sub>2</sub>, Ar, N<sub>2</sub>, NO and CO. The CO<sub>2</sub> product is compressed, condensed and pumped up to supercritical pressure or directly produced in liquid state.

**Key Figures**

- Capacity: 1,000 and 15,000 tpd
- 30 - 50 €/tCO<sub>2</sub> captured
- Energy savings through residual gas
- Gaseous or liquid CO<sub>2</sub>
- Enriched flue gas above 60% CO<sub>2</sub>
- Smart impurities management (high NO<sub>x</sub>)
- CO<sub>2</sub> capture rate: 90-98%

**Main Applications**

- Cement/Lime
- Power plant
- Any applications with CO<sub>2</sub> concentration of >40%

**Reference Examples**

- 2008 - Demo CCS EP for 200 tpd in France (Total - oxyfuels)
- 2010 - Pilot CCS EP for 80 tpd in Australia (Callide - coal burners)
- 2012 - Pilot CCS EPC for 200 tpd in Spain (CIUDEN - coal oxyboilers)
- 2014 - Industrial CCS FEED for 3,500 tpd in US (Futuregen - coal power plant)
- 2015 - Industrial CCS FEED for 1,500 tpd in France (Lafarge - cement)
- 2021 - Pre-FEED in EU (cement)

**Cryocap™ Steel**

This solution was designed to specifically capture CO<sub>2</sub> from steel-making plants, with CO<sub>2</sub> stream concentrations of 20-50%. The gas is first compressed, dried and sent to a PSA (Pressure Swing Adsorption). The PSA pre-concentrates the CO<sub>2</sub> in the offgas while producing a CO rich stream. The pre-concentrated CO<sub>2</sub> stream is compressed and sent to a cold process. There, the CO<sub>2</sub> is recovered through a combination of partial condensation and distillation, which allows the removal of light elements such as Ar, N<sub>2</sub>, H<sub>2</sub> and CO<sub>2</sub>. The CO<sub>2</sub> product can be produced as a gaseous or liquid product. The pressurized CO-rich stream is either recycled

to the blast furnace or used to produce fuels.

**Key Figures**

- Capacity: 300 - 5000+ tpd
- Compact and flexible footprint: compressors, PSA and cold-box can be located in three different plots
- 25-60 €/t CO<sub>2</sub> captured
- Gaseous or liquid CO<sub>2</sub>
- CO<sub>2</sub> capture rate: 80 to 95%

**Main Applications**

- Iron and Steel Production

**Reference Examples**

- 2005 - Pilot CCS EPC for 40 tpd in Sweden (MEFOS)
- 2012 - Industrial CCS FEED for 3,600 tpd in France (ULCOS)
- 2019 - CCU for 800 tpd in Belgium (Steelanol)
- 2020 - CCU LCO<sub>2</sub> Pre-FEED for 350 tpd in Korea

**Cryocap™ NG**

The CO<sub>2</sub>-rich natural gas is first dried and sent to a cold process, where CO<sub>2</sub> is separated from the other components through a combination of partial condensation and distillation. High CO<sub>2</sub> partial pressure favours the partial condensation of CO<sub>2</sub>, and therefore, makes its separation from natural gas even easier. The non-condensable gas is enriched in methane and sent to a membrane for final purification. The CO<sub>2</sub> purity of the product corresponds to pipeline specifications, generally 1 - 10 mol%. The CO<sub>2</sub>-enriched permeate stream of the membrane is sent back to the cold process. The CO<sub>2</sub> and heavy hydrocarbons condense in the cold process and are collected at high pressure. NGL recovery is possible with almost no additional cost. Cryocap™ NG is tolerant to some content of H<sub>2</sub>S. Cryocap™ NG also allows for bulk removal of H<sub>2</sub>S from NG.

**Key Figures**

- Up to 1,000,000 Nm<sup>3</sup>/h
- Separation cost: less than 1 USD/MMBTU
- CapEx savings: > 50% vs. amine absorption (at high CO<sub>2</sub> content)

**Main Applications**

- Natural gas with high CO<sub>2</sub> content (>35%)



### Air Products' Blue H<sub>2</sub>, Syngas & CCUS Portfolio

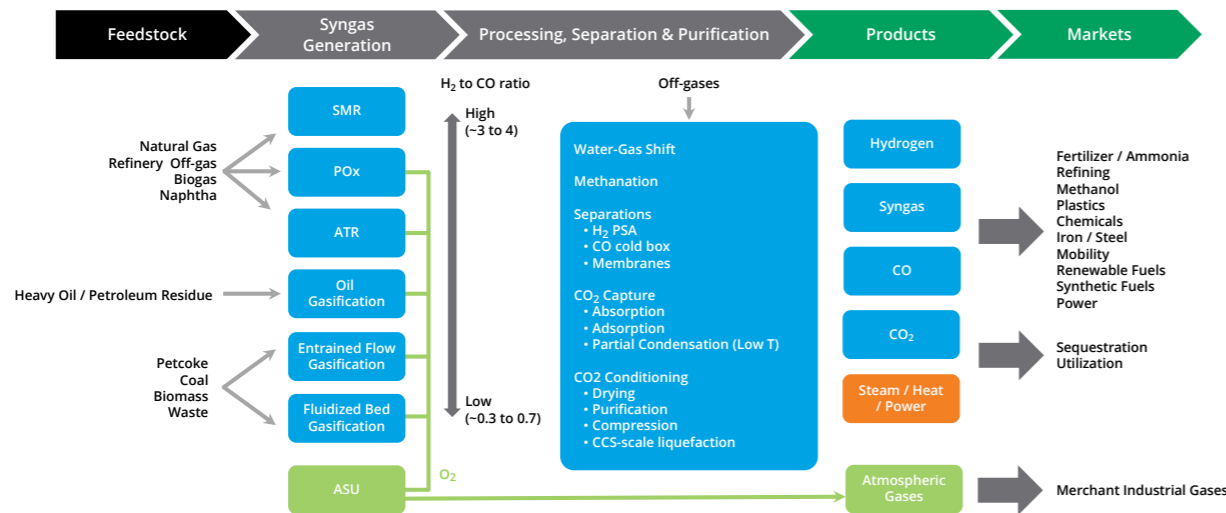

### SUMMARY

Air Products operates in approximately 50 countries, serving clients globally with a unique portfolio of products and technologies in dozens of industries including refining, LNG, chemicals, metals, electronics, and manufacturing. The company's integrated approach to research, development, production, and distribution of industrial gases is a key competitive advantage, helping it become a leading player in this space. Leveraging its integrated platform, Air Products is executing an ambitious growth plan driven by its mission to support clients through the energy transition with environmentally sustainable solutions.

Air Products has successfully demonstrated large-scale carbon capture at its Port Arthur hydrogen facility in Texas, USA. Operating since 2013, key learnings from this project

have helped the company develop the next generation of low-carbon hydrogen projects in its franchise. In Canada, the Net-Zero Hydrogen Energy Complex, targeted for 2024, incorporates +95% carbon capture and hydrogen-fired power generation. In the U.S. Gulf Coast, the Louisiana Blue Hydrogen Clean Energy Complex, targeted for 2026, includes the development of one of the world's largest carbon sequestration operations.

Air Products' diverse portfolio of technologies enables the production of hydrogen and syngas from a variety of feedstocks with diverse options for carbon capture, sequestration and/or utilization. The company maximises value for all stakeholders by operating an integrated industrial gases platform that is continuously focused on safety, reliability, and cost.

### BENEFITS

- A diverse portfolio of technologies enables optimised hydrogen and syngas solutions considering technical, economic, and legislative factors.
- Multifacility integration and monetization of co-products are key enablers of value creation for all stakeholders.
- An integrated approach to technology development and operational excellence has led to superior safety, reliability, and cost performance.

### DESCRIPTION

Air Products is an industry leader with expansive operations, continuously refining and optimizing its technology portfolio at research and engineering centres located in the United States, Europe, Saudi Arabia, India, and China. A global team of engineering and construction professionals are responsible for bringing these technologies to life, building world-scale industrial gas projects including carbon capture, utilization, and sequestration (CCUS) facilities. Completing the technology lifecycle, as one of the sector's largest operators, Air Products gathers real-world data and experience for technology refinement, which is achieved through cross-collaboration among research, engineering, and operations teams. The integrated approach to technology and operational excellence is a major source of strength and differentiation, leading to advantages in safety, reliability, and cost performance.

When developing low-carbon hydrogen projects, Air Products tailors facility configurations from an extensive portfolio of technologies (as seen in the figure on the left hand side). With multiple technologies available for each step of the process, Air Products develops an optimised and integrated solution considering technical, economic, and legislative factors. Hydrogen and syngas generation can be designed for a wide variety of feedstocks, allowing carbon capture from any input stream including solid, liquid, or gaseous hydrocarbons, waste, and/or biomass.

Air Products operates the world's longest hydrogen pipeline in the US Gulf Coast, linking about 25 hydrogen production plants across approximately 1,100 km (around 700 miles) from New Orleans to Texas City, USA. Within the Gulf Coast System, the Port Arthur Blue Hydrogen plant in Texas approached 8 million tonnes of captured CO<sub>2</sub> as of 2021.

### Net-Zero Hydrogen Energy Complex (Alberta, Canada)

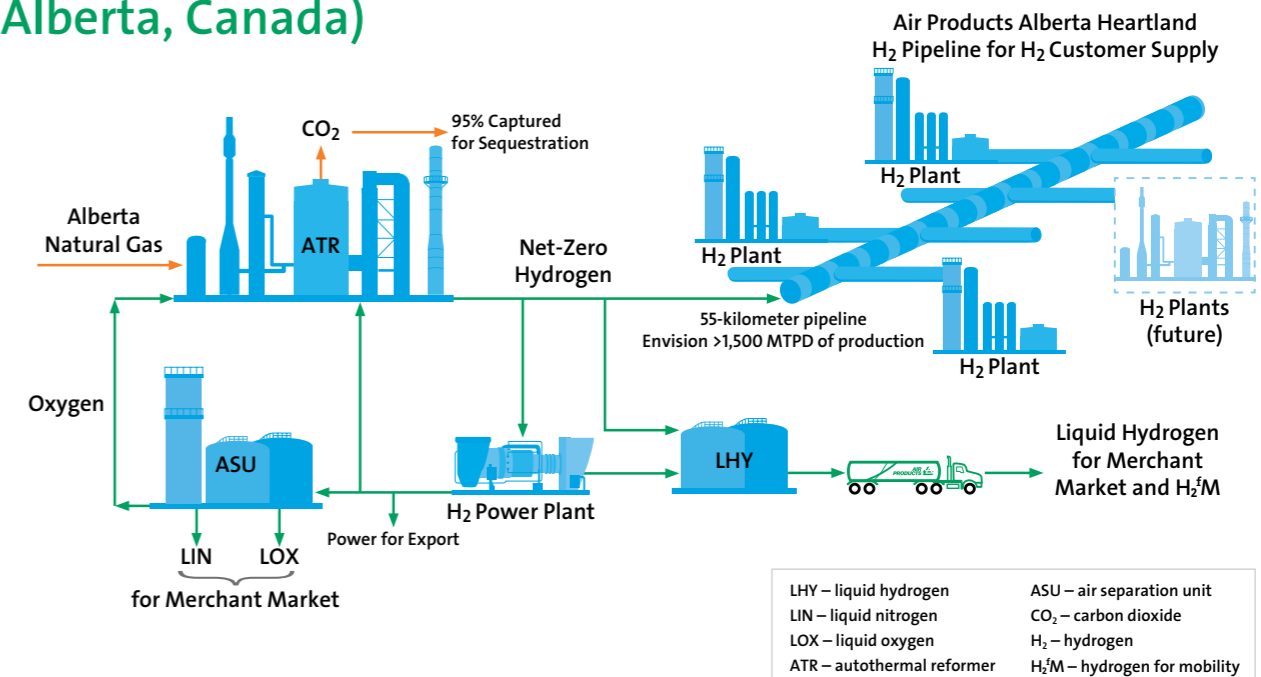



**HYDROGEN TECHNOLOGY PORTFOLIO FOR  
LOW-CARBON SOLUTIONS**

# AIR PRODUCTS

CONTACT

Sina Keivani  
Email: keivans@airproducts.com  
Web: www.airproducts.com

The project, completed in 2013, entailed the retrofit of two existing steam methane reformers (SMR's) with carbon capture units to reduce +90% of high-pressure CO<sub>2</sub> in process streams, equating to approximately half of the direct emissions associated with hydrogen production. CO<sub>2</sub> is captured using vacuum swing adsorption (VSA) separation units, purified by a tri-ethylene glycol (TEG) dryer, compressed to supercritical pressures, and transported by Air Products through an approximately 21 km (around 13 mile) pipeline to an offtaker. A cogeneration unit was integrated into the scope to further enhance the efficiency and reduce emissions. The successful completion and operation of this retrofit project in the middle of an operating refinery was a testament to the company's engineering, project execution, and operations capabilities. Lessons learned from this project in capturing CO<sub>2</sub> from high-pressure streams were critical in developing the company's next generation of low-carbon hydrogen projects.

In advancing its decarbonization mission forward, Air Products is building the Net-Zero Hydrogen Energy Complex in Edmonton, Canada to integrate and decarbonize its Alberta Heartland Hydrogen Pipeline System. Engineering work is currently underway, and the facility is targeted to start up in 2024. Hydrogen will be produced using autothermal reformer (ATR) technology integrated with carbon capture systems achieving +95% capture. The facility will be self-powered using hydrogen-fired turbines and will also export power, helping further reduce emissions by offsetting higher carbon intensity electricity on the grid. Low-carbon hydrogen will be distributed along the 55 km (34 mile) Heartland Pipeline System to multiple offtakers, as well as liquified on-site for distribution to merchant and mobility markets by Air Products' road fleet. This is a common theme across Air Products' portfolio where integration allows for enhanced value creation.

Similarly in the U.S. Gulf Coast, the Louisiana Blue Hydrogen Clean Energy Complex moves the franchise further down the decarbonization path, utilizing natural gas gasification technology, also known as partial oxidation, to produce hydrogen whilst capturing +95% of the associated direct emissions. Air Products has identified the ideal geologic structure for CO<sub>2</sub> storage and will lead its development into one of the world's largest sequestration operations. Once fully commissioned, over 5 Mtpa CO<sub>2</sub> will be captured, transported, and sequestered in this dedicated underground storage facility.

The company's holistic development approach creates opportunities for energy and product integration between different company-owned and/or client facilities. The Louisiana Blue Hydrogen Complex for example not only integrates into the Gulf Coast Hydrogen Pipeline System, described previously, but also serves a new ammonia plant to enable the global distribution of low-carbon hydrogen molecules.

Air Products has extensive experience with designing and operating standalone CO<sub>2</sub> facilities in various scales including merchant CO<sub>2</sub> plants. The company also operates world-scale facilities such as the Doe Canyon Helium Plant in Colorado where approximately 9,000 tpd of CO<sub>2</sub> is separated from Helium using a patented partial condensation separation process.

Air Products is executing an ambitious growth plan driven by its mission to support clients through the energy transition with environmentally sustainable products and solutions. The company can help maximize value for all stakeholders through early engagement in project conception and execution.

## Blue Hydrogen Clean Energy Complex (Louisiana, USA)

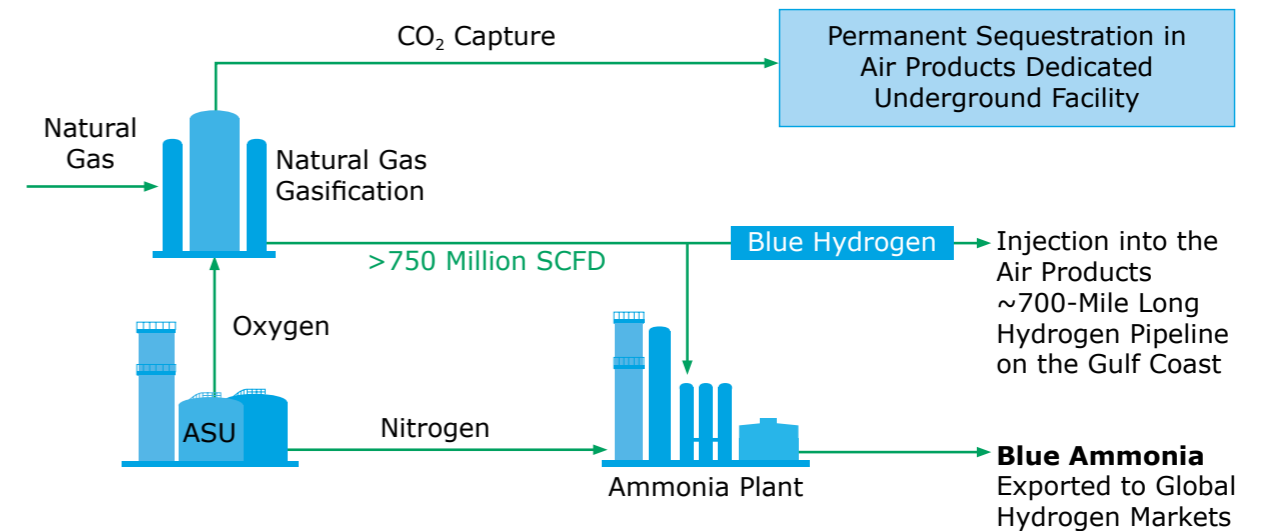





## SUMMARY

Aker Carbon Capture is a dedicated carbon capture technology company with solutions, services and technologies covering the entire carbon capture utilization and storage (CCUS) value chain. We serve a range of industries with carbon emissions, including cement, waste-to-energy, gas-to-power, hydrogen and our carbon capture plants offer several advantages such as low energy requirements, very robust solvents, and excellent HSE performance.

Aker Carbon Capture's Advanced Carbon Capture (ACC™) technology has been developed since 2005 and offered commercially since 2009. It is an energy and cost-efficient post-combustion capture process with minimal environmental impact, based on ACC™ proprietary solvents and proprietary process solutions.

The ACC™ proprietary solvents were developed in an eight years' comprehensive R&D program (SOLVIt) together with industry players and Norwegian research partners. Numerous solvent mixtures have been tested and compared with regards to energy consumption, robustness, toxicity, material compatibility and – most importantly – HSE performance. The SOLVIt program resulted in energy efficient solvents, with no negative environmental impact or occupational hazards.

Due to the testing of different capture technologies at the Technology Centre Mongstad, potential harmful effects of amines used for carbon capture have been brought to attention. Aker Carbon Capture has been involved in this evaluation from the very start, which has resulted in a thorough understanding of potential issues with nitros- and nitra-amines and their formation mechanisms. Proprietary process solutions as well as the robust solvents eliminate the emission of harmful amines or the degradation products from any ACC™ capture plant.

The ACC™ capture technology including the ACC™ solvents and ACC™ Emission System has been tested and verified on flue gases from gas-fired and coal-fired power plants, cement kilns, waste-to-energy plants and hydrogen production plants, with more than 50,000 hours of operating experience from the US, Germany, Scotland, Sweden, Poland and Norway. Based on the extensive testing, the ACC™ capture technology is qualified by DNV GL according to DNV-RP-A203 Qualification Procedures for New Technology and DNV-RP-J201 Qualification Procedures for CO<sub>2</sub> Capture Technology.

## BENEFITS

- Highly energy-efficient capture process with innovative heat integration solutions
- Includes proprietary ACC™ advanced emission control system to prevent the formation of amine mist, which nearly eliminates the emissions of amine and amine's degradation products
- Verified for operating on flue gas from cement kilns, waste-to-energy plants, coal-fired power stations, gas boilers, gas power plants, hydrogen production, and refinery applications, through campaigns with our Mobile Test Unit, and at TCM.
- Aker Carbon Capture's ACC™ CO<sub>2</sub> capture process, including CO<sub>2</sub> liquefaction, intermediate storage and CO<sub>2</sub> export has been qualified by DNV-GL according to DNV-RP-A203 Qualification Procedures for New Technology and DNV-RP-J201 Qualification Procedures for CO<sub>2</sub> Capture Technology
- Includes extremely robust solvents for environmentally friendly operation. The proprietary ACC™ solvents are characterized by low solvent degradation, which is associated with low corrosion rate in the plant, low amine make-up requirement, low emissions of amine's degradation products, low demand for amine's reclamation, and thereby, resulting in low production of reclaimer waste
- No generation of wastewater contaminated with amine traces during normal operation

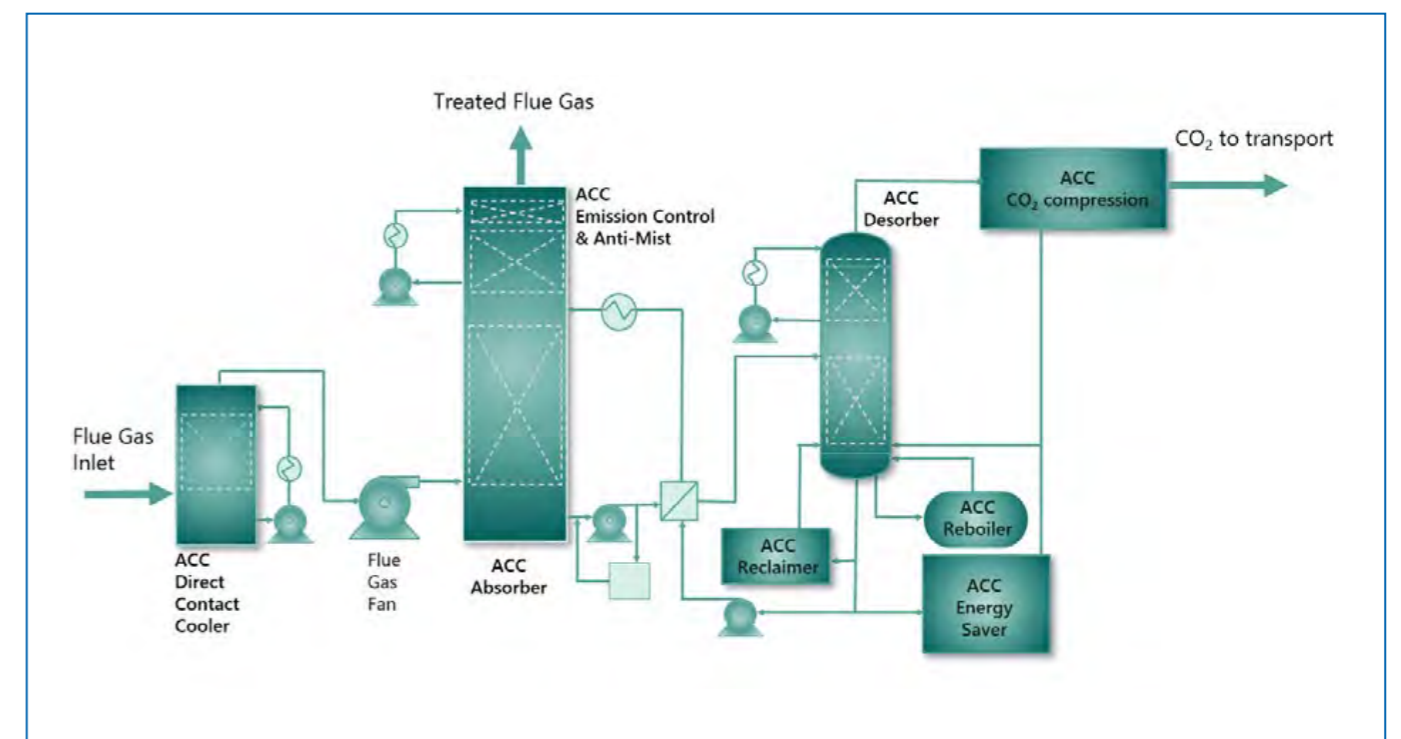



## DESCRIPTION

The main unit operations of the ACC™ process include the ACC Direct Contact Cooler (DCC), the ACC Absorber, the ACC Desorber columns, the ACC Reboiler, the ACC Reclaimer, the ACC Energy Saver, the Flue Gas Fan, and a liquefaction unit (ACC CO<sub>2</sub> Compression).

Flue gas from the client's plant is extracted downstream of any existing flue gas emission control units through the flue gas fan. The flue gas is pre-treated in the DCC. The purpose of the DCC is to cool the flue gas and to remove any acid gases, such as SO<sub>2</sub>, HCl and HF. Condensed water from the flue gas will exit the DCC as a bleed stream.

Flue gas from the DCC is routed to the CO<sub>2</sub> absorber downstream of the booster fan. The CO<sub>2</sub> absorber consists of a CO<sub>2</sub> absorption section in the lower part of the column and a water wash section with an emission control system in the upper part of the column. In the absorption section, flue gas contacts the lean amine solvent in a countercurrent flow regime, absorbing CO<sub>2</sub> from the flue gas. Continuing to the upper part of the column, the emission control system including the ACC™ Anti-Mist design cools and cleans the CO<sub>2</sub>-lean flue gas of traces of amines and potential amine's degradation products, thus effectively preventing emissions of amine and potential amine-degradation products in the form of aerosols. CO<sub>2</sub>-lean flue gas is either emitted from the absorber stack or returned to the existing flue gas stack downstream the flue gas extraction point.

CO<sub>2</sub>-rich amine is drained from the absorber sump. The rich amine solvent is regenerated using steam. The steam is condensed in a reboiler and returned to the battery limits as hot condensate. The increase in temperature during the indirect heating of rich solvent with steam strips the CO<sub>2</sub> out of the solvent. The resulting lean amine is returned to the absorber for reuse in the CO<sub>2</sub> capture process, while the CO<sub>2</sub> exits the top of the desorber.

Further treatment of the CO<sub>2</sub> depends on the CO<sub>2</sub> product specifications. Carbon dioxide (CO<sub>2</sub>) may be liquefied for example, for ship transport, in which case it is dried and stripped of non-condensable inert components to the specified CO<sub>2</sub> quality prior to being sub-cooled and sent to onsite liquid storage vessels. The ACC proprietary CO<sub>2</sub> Compression Solution includes internal heat recovery that reduces the overall steam requirement for the carbon capture plant. Alternatively, the CO<sub>2</sub> is compressed and fed into regional CO<sub>2</sub> pipeline to be transported to permanent storage.

To maintain high solvent performance, a reclaimer is included to intermittently remove impurities and degradation products from the amine solvent. A small amount of concentrated liquid waste is generated in the reclaimer. This reclaimer waste needs to be disposed off batch-wise as chemical waste. Due to the low degradation rate of the ACC™ solvents, along with a properly designed DCC, the amount of reclaimer waste from the ACC™ process is very low compared to standard plants operating with generic solvents such as MEA.

## REFERENCES

### Technology Center Mongstad (TCM)

Aker Carbon Capture designed and was awarded the EPC delivery of the carbon capture test facility plant at TCM. This full-scale CO<sub>2</sub> capture plant captures CO<sub>2</sub> from the gas-fired combined heat and power plant and the catalytic cracker at the Mongstad refinery. Different from competitors, Aker Carbon Capture has not only tested our ACC™ technology at the TCM facility, but designed and delivered the actual plant, which has been in continuous operations since 2012. Customer: Statoil (now Equinor).

### Twence Waste-to-Energy

The project will enable the removal of CO<sub>2</sub> from flue gases at the Twence's waste-to-energy installation facility located at Hengelo, the Netherlands. The captured and liquefied CO<sub>2</sub> will be used primarily by greenhouses in the horticultural sector, where it will enhance crop growth.

CO<sub>2</sub> capture capacity: 0.1 Mtpa

### Norcem Cement Plant

Aker Carbon Capture has worked together with Heidelberg Norcem and partners in developing a full-scale CO<sub>2</sub> capture, conditioning, compression, heat integration, intermediate storage and loading facility for the Brevik cement plant. Carbon dioxide (CO<sub>2</sub>) is being captured from the flue gases of the cement kiln using waste heat recovered from the cement plant and the CO<sub>2</sub> compression plant through a proprietary heat integration technology. The ACC™ capture plant at Norcem will be the world's first CO<sub>2</sub> capture plant from a cement plant when the capture commences in 2024, and is part of the Norwegian Longship Project.

CO<sub>2</sub> capture capacity: 0.4 Mtpa





## SUMMARY

CO<sub>2</sub> removal using amine scrubbing is a well-known process used since 1920 in natural gas treatment. Axens and IFPEN have acquired over 60 years of experience in CO<sub>2</sub> removal from natural gas through the licencing of Advamine™ processes.

Although CO<sub>2</sub> can be easily recovered from pressurized gases with currently available technologies, its recovery from low-pressure or flue gases leads to a significant energy penalty. Furthermore, most solvents currently used in the oil and gas or chemical industries, will be severely degraded by the oxygen present in the flue gases. More suited technologies are therefore required for most CCS applications.

To address these challenges, Axens and IFPEN have been involved in several R&D programs over the past years to develop enhanced CO<sub>2</sub> capture technologies. The DMX™ process is an outcome of these developments.

The DMX™ process is a CO<sub>2</sub> capture process based on absorption using a demixing solvent. The DMX™ solvent consists of a mixture of two organic compounds in aqueous solution, which is demixing under certain conditions of temperature and CO<sub>2</sub> partial pressure.

The DMX™ solvent has a high cyclic capacity (4 times more than the MEA benchmark), whereas only the CO<sub>2</sub>-rich phase needs to be regenerated. As it is very stable, it may be regenerated at higher temperature than amine solvents such as MEA, which allows producing CO<sub>2</sub> at higher pressure (up to 5 barg). Thanks to the properties of DMX™ solvent, the DMX™ process has a great potential for reducing the energy penalty and the cost of CO<sub>2</sub> capture. Compared to the first-generation absorption process using 30 wt.% MEA, the DMX™ process allows a 30% reduction in energy penalty and the subsequent cost of the CO<sub>2</sub> capture (main results from Octavius (ENEL) and Valorco (coordinated by Arcelor Mittal and founded by ADEME) projects). The DMX™ solvent is also less corrosive than MEA, and therefore, carbon steel may be used as the principal material, which reduces the CapEx, as compared to the first-generation solvents.

## BENEFITS

Main Benefits of Axens' DMX™ process are the following.

- Versatile process applicable to multiple types of flue gases (for example: coal power stations, steel mill gas, FCC unit, Steam Methane Reformer, waste incinerator, cement plant, district heating and also electricity from biomass). The DMX™ process is well-adapted to CO<sub>2</sub> capture on industrial smoke or industrial gas when the CO<sub>2</sub> partial pressures are low to medium, typically below 1 bara.
- Low steam energy consumption from 2.3 to 2.9 GJ/tCO<sub>2</sub> depending on application and capture rate
- Thermally stable solvent with low degradation rate
- CO<sub>2</sub> produced readily under pressure up to 5 bars for significant compression cost-savings
- High capture rate achievable (> 95%) and high purity of produced CO<sub>2</sub> (> 99%)
- - 30% of CO<sub>2</sub> capture cost compared to 1st generation amines

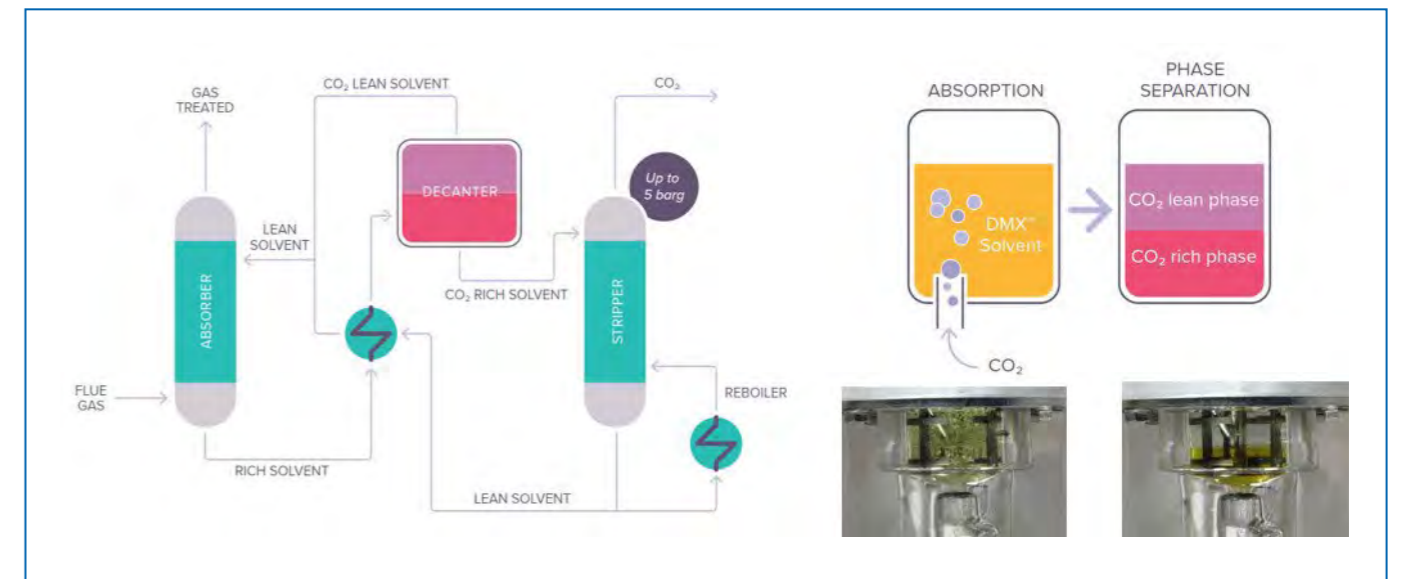



## DESCRIPTION

The DMX™ process can be broken down into four main sections.

A CO<sub>2</sub> absorption section (absorber): the conditioned gas is washed in a counter-current absorber with the DMX™ solvent. The absorber is equipped with an intercooling stage to enhance the absorption capacities of the solvent and reduce the solvent circulation to its minimum. A water wash section is installed at the top of absorber to limit the solvent losses with the treated flue gas. A DMX™ solvent demixing and settling section (decanter): the CO<sub>2</sub>-rich solvent recovered at the bottom of the absorber is pumped and heated in the rich/lean solvent exchanger, leading to demixing of the latter. After decantation, three phases are obtained:

- A liquid phase low in CO<sub>2</sub> can be returned directly to the absorption section.
- A liquid phase rich in CO<sub>2</sub> is directed to the regeneration section.
- A gas phase rich in CO<sub>2</sub>

A regeneration section (regenerator): the CO<sub>2</sub>-rich phase coming from the settling section is thermally regenerated by steam stripping effect (generated in situ with a reboiler operating with medium-pressure steam) producing a gaseous effluent rich in CO<sub>2</sub> at the top of the column. The regenerated heavy phase is sent to a regenerated solvent hold up drum, before being recombined with the low CO<sub>2</sub> light phase (from the settling section). It is then cooled down through rich/lean solvent exchanger and lean solvent cooler before being returned to the absorption section.

The gaseous CO<sub>2</sub> streams recovered at the decanter and regenerator overhead are cooled down to recover condensed water before being mixed and routed at battery limit under pressure. The DMX™ process has already undergone 10 years of development from laboratory scale to global optimisation in the power and steel industries and has now reached Technology Readiness Level 4 (TRL4).

The technology now requires to be demonstrated at industrial scale in order to be commercialized by Axens. It will be done through the 3D Project that intends to build a demonstration unit at the steel mill of Arcelor Mittal in Dunkirk located in the north of France. This project will also study the full-scale CO<sub>2</sub> capture, conditioning, transport and storage of 1 Mtpa CO<sub>2</sub> from blast furnace gas. This project will contribute to the development of a CO<sub>2</sub> hub located in Dunkirk and connected with the storage facilities like those foreseen with the Northern Lights (or Longship) Project supported by the Norwegian government.

The demonstration plant with a capacity of 0.5t CO<sub>2</sub> captured/h has been delivered by Axens at the end of 2021 at Arcelor Mittal's steel mill in Dunkirk. The operation of the demonstration plant will start in Q2 2022 and is expected to last until mid-2023.

Additional information is available at the following web address: <https://3d-ccus.com>







**SUMMARY**

C-Capture has developed the world's most energy-efficient solvent technology for carbon capture that delivers step-change performance-improvements over the current state-of-the-art whilst being robust enough for use in even the most challenging of industrial applications.

C-Capture's novel solvents are based on salts of simple organic acids, representing a new paradigm in carbon capture technology. When compared to traditional, amine-based technologies, this alternative approach to the chemistry of carbon capture, in combination with tried and tested engineering concepts, delivers significant benefits to customers including lower overall cost of capture, lower O&M costs, lower environmental impact, easier permitting, and lower solvent management costs.

The low cost of capture for C-Capture's technology is derived from the reduced energy demand of the process. In addition, C-Capture's solvent components are all highly thermally stable, meaning that higher desorber temperatures can be achieved, creating far greater CO<sub>2</sub> pressures on its release, and reducing the compression energy to prepare CO<sub>2</sub> product for transport and storage.

C-Capture's biodegradable solvents are environmentally benign, both inside and outside the capture plant. Manufactured from simple, readily available commodity chemicals, the solvents exhibit lower corrosivity than competing amine-based solvents, thus reducing the need

for expensive, high-grade materials of construction and minimising the need for expensive plant maintenance shutdowns.

C-Capture's technology is suitable for a wide range of industrial applications including, but not limited to, biomass-, coal-, waste-, and gas-fired combustion processes, cement and lime manufacture, hydrogen production, biogas and natural gas refining, and even industrial applications that might normally be considered too hard to abate with amine-based solvents such as glass furnaces, and iron and steel production. These latter applications are possible as a result of high chemical stability of C-Capture's solvents, as well as their high selectivity towards CO<sub>2</sub>, which minimises the scope for solvent degrading side reactions.

C-Capture's technology has been successfully demonstrated at a range of locations on various applications, including biogas and landfill gas upgrading, and biomass fired post-combustion capture at Drax Power Station, N. Yorkshire, UK and on SINTEF's world-renowned pilot facility at their CO<sub>2</sub> Laboratory in Tiller, Norway. Building on these successes, C-Capture is now working to design and build an intermediate scale demonstration plant on a waste wood gasification process, as well as a series of engineering feasibility studies across a variety of industrial sectors, one of which will be selected to go on to be the first full-scale, commercially operated demonstration of the technology.

**BENEFITS**

- Significantly reduced process energy requirements (1.5-1.8 GJ/t CO<sub>2</sub>) due to low steam requirements and reduced costs of compression due to higher CO<sub>2</sub> release pressure
- Environmentally benign solvent manufactured from nitrogen/amine-free biodegradable components
- High tolerance to impurities, including O<sub>2</sub>, SO<sub>x</sub> and NO<sub>x</sub>, reducing the need for feed-gas pre-cleaning
- Reduced solvent management costs due to high thermal, chemical, and oxidative stability, and low volatility, minimising solvents losses per tonne CO<sub>2</sub> captured
- Low levels of environmentally benign emissions due to low volatility of solvent components and low rate of degradation product formation
- Reduced operations and maintenance costs due to less corrosive solvent



C-Capture's BECCS pilot plant operating at Drax Power Station, N. Yorkshire, UK

**DESCRIPTION**

CCS is widely recognised as an essential component of any credible path to net-zero carbon emissions by 2050. To roll out CCS broadly enough to meet this target, affordable technologies, which are applicable across industry and energy generation are required. The perennial nascency of the carbon capture industry is, in part, a consequence of today's state-of-the-art not meeting these affordability and applicability criteria, and therefore, more innovation is required. It is this innovation gap that C-Capture's technology has been developed to address.

The core of C-Capture's technology is their family of unique solvents, based on a fundamentally new approach to carbon capture chemistry, deployed into well known, tried and tested engineering concepts and unit operations. This

combination of highly innovative solvent technology and industry standard process engineering, reliably delivers C-Capture's distinctive commercial, environmental, and operational benefits.

To date, the step-change performance improvements of C-Capture's technology have been demonstrated in their laboratories in Leeds, UK, and validated through small-scale biogas and landfill gas upgrading trials, and via pilot plant trials on biomass derived flue gas at Drax Power Station, N. Yorkshire, UK and SINTEF's 1 tpd pilot plant in their CO<sub>2</sub> Laboratory at Tiller, Norway (vide infra).

One of the key disadvantages associated with the state-of-the-art amine-based technologies is the significant energy penalty of the process; a parasitic load of 2.5 GJ/tonne CO<sub>2</sub>



**DESCRIPTION CONT.**

captured or greater is typical. In a like-for-like comparison with other commercially available solvent technologies, C-Capture can deliver energy penalty reductions of up to 40%, with significant gains made from the reduced enthalpy of the capture reaction lowering the energy input to release the CO<sub>2</sub>, lower solvent volatility reducing losses to vapours, lower heat capacity of the solvent improving the efficiency of heat integration, and increased CO<sub>2</sub> release pressure reducing the compression energy demand.

There are additional benefits to eliminating amines from C-Capture's solvents, over and above reducing the energy penalty of the process. One is that the corrosivity of the solvents is much reduced, cutting the costs of essential plant maintenance and opening up the possibility of using less expensive materials of construction.

Recognising the enormous scales at which CCS will need to be deployed, C-Capture's solvent has been designed for minimal environmental impact. To that end, only biodegradable components are used in the manufacture of C-Capture's solvent, potentially problematic elements, such as nitrogen or sulphur, have been engineered out (which has the added benefit of making end-of-life disposal significantly cheaper and easier), and technologies have been identified which will allow the petrochemicals in the solvent supply chain to be reduced, or phased out altogether, in favour of bio-derived feedstocks. A future for C-Capture where CO<sub>2</sub> captured at one site is used to make the solvent to capture more CO<sub>2</sub> at another site is planned.

A crucial benefit of C-Capture's technology is that it is a new concept in carbon capture chemistry, not just a minor variation on what has come before. This has allowed their chemists to design to a range of criteria, not just maximising CO<sub>2</sub> capture rate or capacity. One such criterion has been to maximise the robustness of the solvents, particularly towards more challenging flue gases with high levels of reactive impurities from industries, which are normally considered hard to abate such as glass, or iron and steel. In all tests, C-Capture's designed-to-be-robust solvent has shown significantly reduced degradation which will translate to lower solvent management costs at full scale.

This built-in robustness is attracting the attention of a range of partners across challenging applications where C-Capture's technology will not only reduce costs, but sometimes open the door to deploying carbon capture at all. Since extraordinary claims require extraordinary evidence, C-Capture is deploying a series of Carbon Capture Solvent Compatibility Units (CCSCUs) across these sectors through 2022/23 to gather the data to back up their claims of solvent resilience and performance stability in such challenging applications. For C-Capture, their partners, and their customers, this is recognised as critical to de-risk future projects and investments in CCS at commercial scale, and deliver the cost reductions required to decarbonise all industry sectors.

**BECCS Piloting**

A critical element of the net-zero concept is that of negative emissions to offset those from activities which are too hard to decarbonise in the short or even medium term. One such path to negative emissions is BioEnergy with Carbon Capture and Storage (BECCS) whereby the CO<sub>2</sub> absorbed by biomass during its growth is released when the biomass is combusted, then captured and stored.

Drax Power Station, N. Yorkshire, is the UK's largest power station, and has converted four of its boilers to run on 100% biomass. In 2019 Drax was the first company in the world to announce its ambition to become carbon negative by 2030, by deploying BECCS. C-Capture's technology is one of those being evaluated to deliver this ambition.

C-Capture's BECCS pilot plant at Drax has been operational since February 2019, and has confirmed the compatibility of the solvent with its biomass flue gas, and validated the low rate of solvent degradation and low environmental impact of the process. C-Capture's latest, fully integrated, prototype capture plant will begin operating at Drax in 2022, to demonstrate optimised process engineering designed to maximise the unique benefits of the solvent technology.

Additional work at SINTEF's CO<sub>2</sub> Laboratory pilot plant at Tiller, Norway has further confirmed compatibility of C-Capture's solvent with biomass flue gas. For those trials, the burner which provided the flue gas for the trials was fuelled with Drax's biomass pellets. A parallel campaign was run using 30%w/w aq. MEA as a baseline to allow like-for-like comparisons to be made. The trials confirmed the lower emissions profile even with particulates present, the reduced rate of solvent degradation, and the reduced energy penalty of C-Capture's solvent.

C-Capture has recently completed the design of an intermediate scale demonstration plant for Ince Bio Power, owned by Bioenergy Infrastructure Group, in Cheshire, UK. The project is a critical steppingstone in scaling up the technology. It has developed significant learnings

in constructability of the plant, and has supported the innovative development of a semi-modular approach to construction strategy. This will support further explorations towards pre-assembled modular approach for future plant designs.

In summary, C-Capture's technology offers step-change performance benefits which address many of the limitations of current state-of-the-art solvent technologies. These translate into specific value propositions for customers including lower energy demand, operating costs, and environmental impact, and the potential to deploy across a far wider range of industrial applications. C-Capture has developed the carbon capture technology needed for the world's net zero targets to be achieved.



One of C-Capture's Carbon Capture Solvent Compatibility Units



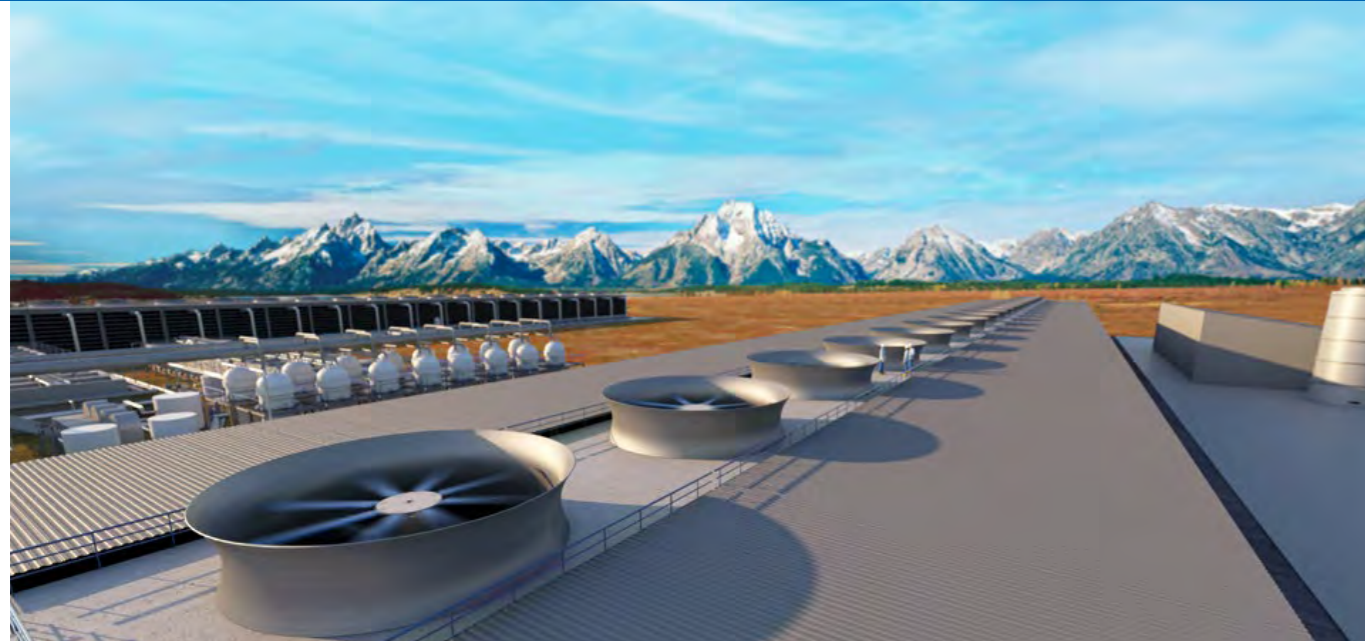

## SUMMARY

Direct Air Capture (DAC) is a technology that captures carbon dioxide (CO<sub>2</sub>) directly from the atmosphere with a mechanical system. This is similar to how trees absorb CO<sub>2</sub> for photosynthesis, except that DAC does it much faster, with a much smaller land footprint, and delivers the CO<sub>2</sub> in a pure, compressed form. The captured atmospheric CO<sub>2</sub> can then be permanently and safely stored in geologic reservoirs to deliver negative emissions, or used to produce low carbon intensity products, such as fuels including diesel and aviation fuel that work in existing vehicles and infrastructure.

For more than a decade, Carbon Engineering (CE) has pioneered a liquid sorbent-based DAC system optimized for scale. Today, alongside industry-leading development partners, CE is working to deploy large-scale commercial facilities globally. Industrial facilities that use CE's DAC technology can be built in one or more modules, each capable of capturing 0.5 Mtpa CO<sub>2</sub>.

## BENEFITS

Key features of CE's DAC technology include:

- **Scalable** – CE's technology can be built in 0.5 Mtpa CO<sub>2</sub> modules to capture millions of tonnes of atmospheric CO<sub>2</sub> annually using known equipment with industrial precedent.
- **Affordable** - Peer-reviewed research published in Joule Journal (2018) showed how CE's technology could achieve capture costs of below US\$100 per tonne at megatonne-scale.
- **Freedom of location** - Facilities can be built on non-arable land, avoiding competition with agriculture and other land use priorities.
- **Transition ready** – Existing equipment, supply chains and workforce skillsets will be in demand as the world builds this new, clean infrastructure. Each project is expected to create thousands of construction jobs and hundreds of steady-state operations jobs.

## DESCRIPTION

DAC technology captures CO<sub>2</sub> by pulling in atmospheric air. Then, through a series of chemical reactions, CO<sub>2</sub> is extracted from the air while returning the rest of the air to the environment. DAC is a different, and complementary, technology to “carbon capture and storage”, which removes CO<sub>2</sub> from industrial flue gas instead of the atmosphere.

CE's DAC technology approach is focused on achieving large, industrial scale at an affordable price. To achieve this, CE's DAC process uses chemical reactions and a closed loop system to absorb CO<sub>2</sub> from the air, using the same chemicals over and over to minimize waste and consumables. CE's solution borrows existing and widely used equipment and processes from other industries, and innovates and integrates them to deliver a DAC system with low scale-up risk, known supply chains, and reliable equipment costs.

There are a number of uses for atmospheric CO<sub>2</sub> captured through DAC, but CE is focused on delivering solutions for two types of industrial facilities:

1. **DAC and sequestration plants** combine DAC with secure geologic storage of CO<sub>2</sub> to deliver the permanent and verifiable removal of CO<sub>2</sub> from the atmosphere. This provides a mechanism to help

difficult-to-decarbonize sectors, such as aviation, address their emissions faster and at a lower cost than many existing mitigation solutions. In the future, in a post net-zero world, these same facilities could be used to address legacy emissions, creating an opportunity for climate restoration.

2. **AIR TO FUELS™ plants** capture atmospheric CO<sub>2</sub> and combine it with green hydrogen to produce low carbon intensity fuel that is drop-in compatible with existing vehicles and infrastructure. In addition to fuel, atmospheric CO<sub>2</sub> can also be used to produce other low carbon intensity products, such as concrete and chemicals.

To enable rapid and widespread deployment of DAC solutions, CE licenses its technology to development partners around the globe so multiple plants can be built in parallel. The first commercial facility to use CE's DAC technology is being developed in the United States by 1PointFive. With construction expected to begin in 2022, the facility is expected to be capable of extracting one Mtpa atmospheric CO<sub>2</sub> once complete. This facility provides a blueprint for global projects, supporting the design of additional facilities already progressing in multiple markets around the world.



Carbon Engineering's Innovation Centre and Advanced Development Headquarters located in Squamish, Canada.





## SUMMARY

Carbon Clean is a global leader in cost-effective industrial carbon capture technologies and services.

Headquartered in the UK, we are focused on helping hard-to-abate industries achieve their net zero targets by reducing the cost of carbon capture. With over a decade of experience in designing, building, financing and operating industrial carbon capture systems, we are working with leading industrial companies globally to implement our carbon capture solutions. Innovation is at the heart of all we do, and we are dedicated to devising solutions that will overcome barriers to the mass adoption of carbon capture. In 2021, we launched a breakthrough technology that will revolutionise the sector – CycloneCC™.

It is a fully modular carbon capture solution that addresses two major concerns from industries who are considering carbon capture – cost and space. CycloneCC™ uses a breakthrough combination of two proven process intensification technologies: Carbon Clean’s advanced, proprietary amine-promoted buffer salt solvent (APBS-CDRMax®) and rotating packed beds. As a result, the physical footprint of CycloneCC™ is up to 50% smaller than conventional carbon capture units and CapEx and OpEx costs are also reduced by 50%.

Built on a pre-fabricated skid mount, every CycloneCC™ unit will be delivered ready to install and with the potential to be operational in less than eight weeks, avoiding a lengthy and complex design, build and engineering process. There is minimal disruption to operations and the safety risks onsite are significantly reduced.

As a compact, modular scalable solution, it also allows companies to increase CCUS capacity over time in line with their decarbonisation strategies. In terms of resources, energy, time, and space, CycloneCC™ is changing the landscape of carbon capture.

For many industrial companies, carbon capture will no longer require a massive infrastructure project – instead your carbon capture unit will arrive and be up and running in a matter of weeks. CycloneCC™ is a ground-breaking solution that makes carbon capture simple, accessible, and affordable.

*“Carbon Clean’s innovative new technology will help make the widespread industrial adoption of carbon capture a reality,” said Greg Hands, UK Minister of State for Business, Energy and Clean Growth.”*

## BENEFITS

CycloneCC™ is a breakthrough modular technology that brings carbon capture within reach of more companies than ever before. Its benefits include:

- Cost-effective carbon capture - CapEx and OpEx are reduced by up to 50%
- Compact size – mass transfer equipment is 10 times smaller, and its overall physical footprint is up to 50% smaller than conventional carbon capture units
- Modular and scalable – units are stackable and can be added over time to increase carbon capture capacity in line with a company’s decarbonisation strategy
- Simpler and safer installation - the pre-fabricated, skid-mounted unit is delivered ready to install and can be operational in less than eight weeks, with minimal site disruption and faster permitting





**DESCRIPTION**

Carbon Clean has been providing innovative carbon capture technology and services across a range of industries for over a decade. We offer technology licenses and solvent supply, a full process design package and proprietary equipment, and end-to-end systems – including designing, building, financing and operation.

We installed the world’s first commercial CCUS plant at Tuticorin Alkali Chemical and Fertilizers Ltd. in India and our technology is now operational at 44 sites across North America, Europe and Asia.

Our next generation technology is designed to integrate with existing industrial operations for minimal disruption and maximum cost-effectiveness. We enable hard-to-abate industries to not only reach net zero, but also leverage decarbonisation incentives and join the growing global circular carbon economy.

Scaling up CCUS is essential to achieving global net zero targets, but several barriers have prevented widespread adoption, in particular cost and onsite space restrictions. For example, a survey of hard-to-abate industries conducted by Decarb Connect – Scaling up CCUS – market insights – found that space remains a major concern and that industries need to be able to integrate carbon capture solutions within their existing facility.

Most industrial sites are already optimised in terms of layout, and traditional carbon capture solutions can almost be as big as some of the plants already on site. Therefore, a reduced physical footprint is critical to making carbon capture viable for more sites.

Our latest innovation – CycloneCC™ – addresses these barriers. As a modular, pre-fabricated and skid-mounted carbon capture solution, CycloneCC™ reduces the overall cost of carbon capture by up to 50% – bringing it within reach of many more companies.

Using a breakthrough combination of two process intensification technologies, CycloneCC™ has a physical footprint that is up to 50% smaller than conventional carbon capture units and can be installed in less than eight weeks.

**Process intensification technologies**

The two process intensification technologies are Carbon Clean’s advanced, proprietary amine-promoted buffer salt solvent (APBS-CDRMax®) and rotating packed beds (RPBs). The solvent and RPBs are well-established technologies which, when combined, enable CycloneCC™ to be more cost and space-efficient than conventional carbon capture technology while matching the performance.

Our APBS-CDRMax® solvent has been formulated to optimise carbon capture performance using fast-reacting amines and high-capacity salts. The solvent chemistry allows for rapid removal of carbon dioxide from flue gases with CO<sub>2</sub> concentrations ranging between 2.5-25 vol.%. The solvent has greater stability, lower corrosivity and lower regeneration energy requirements than the benchmark amine.

The absorption process is further improved using the RPB absorber, which contains a disk of packing material that rotates about its axis. This generates a centrifugal force within the packing, which enhances the CO<sub>2</sub> absorption process. Essentially, the solvent and flue gas move past each other more rapidly allowing for a higher rate of mass transfer.

This enhancement of the absorption process results in 10 times less volume, and therefore, a corresponding reduction in equipment size to achieve the same performance as the conventional options.

The solvent is introduced into the RPB at its centre, where it is sprayed on to the packing via a liquid distributor. When the solvent contacts the packing, the centrifugal force applied to the solvent from the rotational motion forces the solvent to travel radially towards the outer edge of the packing where it drains down to a sump before being pumped to the next stage of the process.

The flue gas is introduced to the RPB from the outer edge of the packing and exits at the inner edge, where the solvent enters. The gas and the liquid contact each other in a counter-current fashion, ensuring maximum contact and greater absorption.

The CO<sub>2</sub> that is present in the flue gas selectively reacts with the active components in the solvent, temporarily ‘locking’ the CO<sub>2</sub> in the solvent.

RPBs are ideally suited to carbon capture as they can handle very high gas and liquid volumes. We have been working with academic and industry partners in the UK and US to test and develop the potential of RPBs.

**Wide ranging benefits**

CycloneCC™ is set to revolutionise carbon capture and deliver huge benefits to industries that have limited options to decarbonise.

Apart from its radical reduction in size and up to 50% reduction in both the CapEx and OpEx, it offers incredible flexibility to companies that are on a decarbonisation pathway. As a modular, scalable solution, it uses standardised designs that allow companies to add units in line with their decarbonisation trajectory, phasing the investment required to achieve their goals.

Built on a skid mount, each CycloneCC™ unit will be delivered ready to install and can be fully operational in less than eight weeks. This minimises site disruption and safety concerns, as well as facilitating faster permitting.

The technology is particularly suitable for use with small to mid-size emission point sources. It can also be used to

capture carbon from several point sources – as a compact and modular solution it can be installed at multiple locations across a site.

**Next steps for CycloneCC™**

CycloneCC™ has been successfully pilot-tested at 1 tonne CO<sub>2</sub> per day (TPD) and is currently being commercialised at 10 TPD and 100 TPD with select partners, including CEMEX, Chevron and Veolia. For example, CEMEX has announced a project at its Rüdersdorf plant in Germany to use CycloneCC™ technology to capture 100 TPD of CO<sub>2</sub>, before increasing the carbon capture by an additional 300 TPD. The plant is expected to be operational by 2026 and a study will also be completed to investigate how to scale up to 2,000 TPD of CO<sub>2</sub>.

With Chevron, we are seeking to develop a carbon capture pilot using CycloneCC™ on a gas turbine in San Joaquin Valley, California. While, with Veolia, we are integrating CycloneCC™ technology into its energy recovery facilities in the UK. CycloneCC™ has also received some Royal attention in the UK – HRH The Prince of Wales saw it on site at Doosan Babcock’s Emissions Reduction Test Facility in Renfrew, Scotland, while at COP26. Our intention is to mass produce CycloneCC™ units to meet global demand and deliver the huge increase in the scale and pace of CCUS adoption across industry that is required to reach net zero.

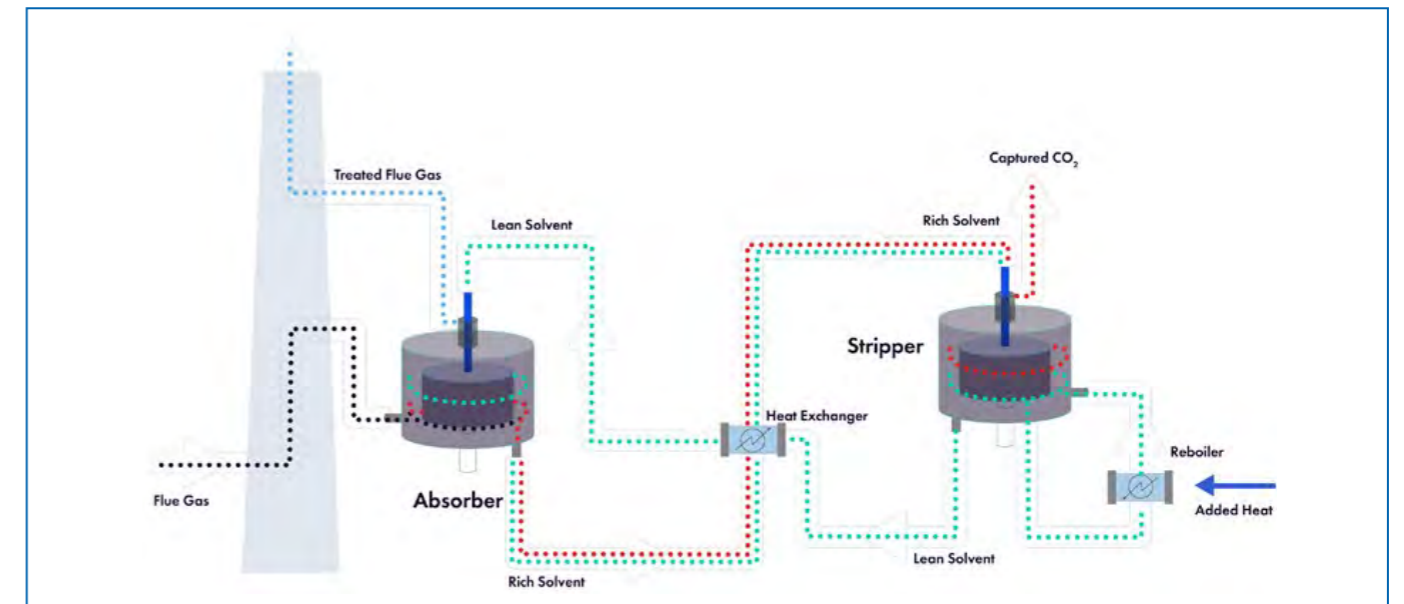

Cyclone CC Plant Block Flow Diagram





**CAPSOL EoP™ - THE FUTURE TECHNOLOGY ENABLING NEW REVENUE STREAMS AND LOWEST CAPTURE COSTS FOR ALL EMITTERS**

**SUMMARY**

CO2 Capsol has developed and offers an environmentally friendly, non-carcinogenic, energy-efficient, and affordable carbon capture technology Capsol EoP™ (End of Pipe), for large scale emitters like energy-from-waste (EfW), biomass, cement, power plants and industrial facilities. Capsol EoP™ utilises the safe and proven Hot Potassium Carbonate (HPC) solvent.

HPC as an absorption solvent of CO<sub>2</sub> is well-documented and used in thousands of plants globally in multiple industries. However, until recently, using HPC for post combustion carbon capture from flue gases was discarded as a viable option due to high energy demand (and hence cost).

To solve this problem, CO2 Capsol has developed the Capsol EoP™ (End of Pipe) technology – a standalone, retrofit unit, with a patented energy re-circulation process, which offers low capture cost and the flexibility to monetise heat and electricity.

A simplified overview of the process is presented in the figure to the right. The CO<sub>2</sub> rich flue gas is compressed to around 5-8 bar(a) (depending on the CO<sub>2</sub> concentration) before it enters the bottom of the absorber, where the pressurised flue gas reacts with the downwards flowing solvent. The lean flue gas leaves the absorber column at the top. The CO<sub>2</sub> rich solvent leaves the absorber at the bottom, is depressurised, and led to the top of the

desorber, where the partial CO<sub>2</sub> pressure is low, forcing the solvent to release its high CO<sub>2</sub> content to the steam flow. The pure CO<sub>2</sub> leaves the top of the desorber, from where it can be liquified and further processed. The lean solvent is led back to the top section of the absorber.

Carbon capture using Capsol EoP™ has several advantages, in addition to being environmentally friendly and safe, it is energy-efficient, flexible, and cost competitive. Furthermore, it ensures the absence of potentially carcinogenic degradation products and harmful emissions, both in the lean flue gas and the captured CO<sub>2</sub>. In addition, HPC is low-cost (absorbent consumption cost of approximately EUR 0.3/ton of CO<sub>2</sub> captured).

Capsol EoP™ can be run on electricity-only or utilise excess steam from the host plant, if available. Thus, a costly investment in external steam production or the reconstruction of the existing plant is not required. Additionally, Capsol EoP™ offers great flexibility for the operation of the capture plant – optimising either for minimum electricity consumption, or for maximised internal heat generation, for example for district heating.

For CO2 Capsol, carbon capture is not only about capturing carbon, but also the optimal integration of our solution into the host plant's processes to decrease complexity and create new revenue streams for the industrial emitter.

**BENEFITS**

CO2 Capsol has a large portfolio of patents, developed over a 15-year period.

- **Cost Competitive:** The patented energy re-circulation enables lowest carbon capture costs and flexibility to monetise heat and/or electricity from the capture unit.
- **Safe, Non-Carcinogenic Solvent, Free of Harmful Emissions:** The use of Hot Potassium Carbonate (HPC) is non-toxic, non-flammable, non-carcinogenic and environmentally friendly.
- **Flexible And Scalable:** A single Capsol EoP™ unit can process flue gas from plants with emissions of up to 2.5 Mtpa CO<sub>2</sub> (with flue gas concentrations of 20%). Two or more Capsol EoP™ units will operate in parallel for facilities with emissions of more than 2.5 Mtpa.
- **Minimal Plant Impact:** The system can be run on electricity only. There is no external steam required. No modification needed.
- **Experienced Team:** Technical and commercial experts from the Energy, Chemical and Oil&Gas industry, with 25+ years' experience.

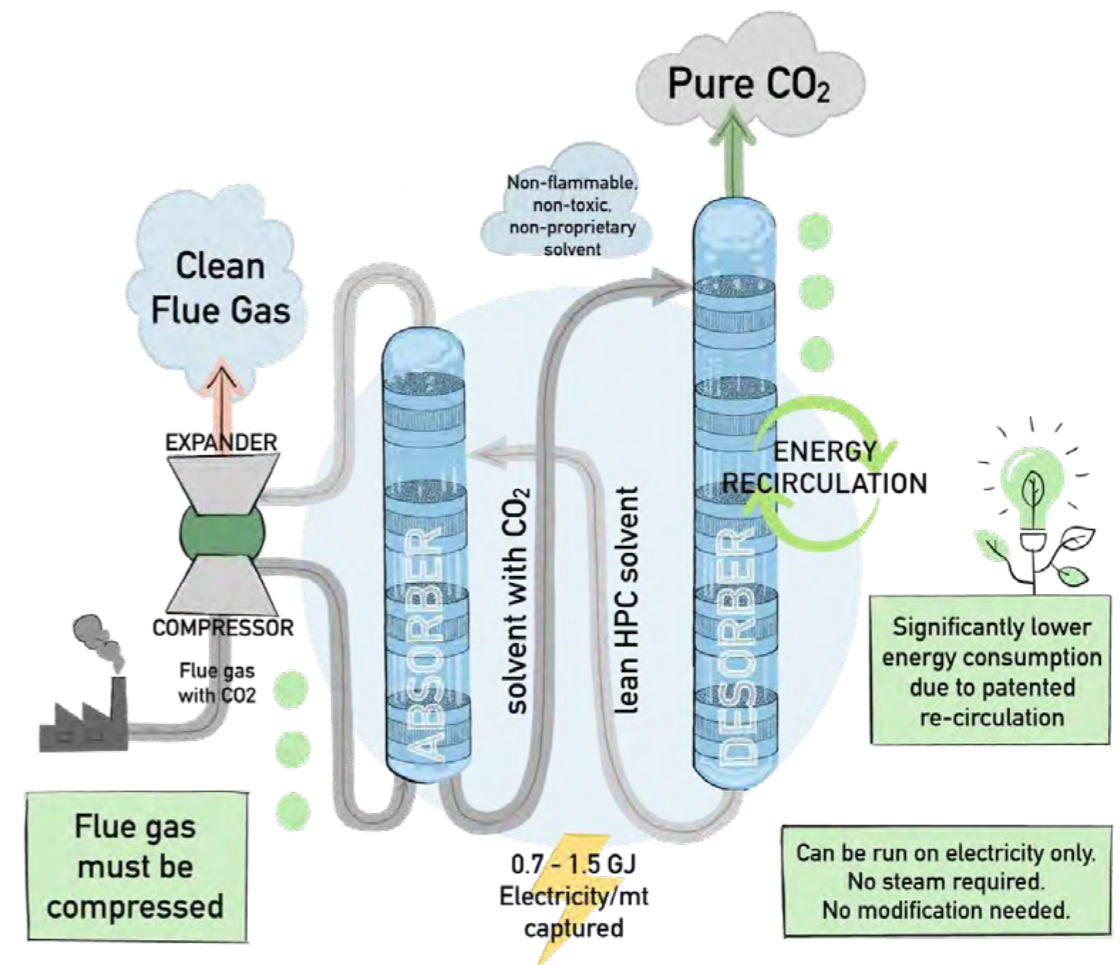



## DESCRIPTION

### Optimisation of Capasol EoP™

The Capsol EoP™ process uses electricity for running the main flue gas and steam compressors in the system. In addition to this, it utilizes the energy contained in the incoming flue gas.

The heat recuperation system manages to efficiently produce 1.3 bar steam out of 75 to 90 °C water by heat pumping. Process waste heat from the parent plant at temperatures above 75 °C may be used in the Capsol EoP plant (optimised for minimum electricity consumption) to decrease the energy demand of the overall system. When the capture plant is optimised to supply a district heating network, a minimal increase of electricity consumption can result in a significant output of valuable energy in the form of heat. In addition, the Capsol EoP™ solution can profitably make use of energy from the CO<sub>2</sub> compressor intercoolers (in the liquefaction plant) at temperatures above 75 °C in the energy recuperation.

Depending on the temperature, the energy in the flue gas entering the Capsol EoP™ unit can also be used in the Capsol EoP™ heat recuperation. This is also an area of optimisation for each specific case.

Whether to optimise for lowest electricity consumption or maximum heat into the district heating system is analysed for each specific plant based on close dialogue with the plant owner.

### Investment cost of equipment for a capture plant – CapEx and OpEx

Investment cost is project specific, however the following is provided as an example.

Main factors affecting the CO<sub>2</sub> capture costs is the cost of energy used in the capture process and the CO<sub>2</sub> concentration in the flue gas.

The capital cost for capturing 0.4 Mtpa CO<sub>2</sub> from an industrial facility or incineration plant with flue gas concentration of 15% CO<sub>2</sub> will be within the range of EUR 40 million, excluding any civil works and liquefaction of CO<sub>2</sub> for export.

In a recent study, the total OpEx was estimated to be within the range of EUR 15-18 per tonnes of captured CO<sub>2</sub> (excluding compression and liquefaction of CO<sub>2</sub> for export).

### CapsolGo™ – Affordable demonstration of safe carbon capture

CapsolGo™ is the answer to the many challenges of industrial emitters, who consider investing into a full-scale carbon capture plant. CapsolGo™ is a small-scale carbon capture demonstration unit for industrial facilities such as energy-from-waste, biomass, cement, and power plants. CapsolGo™ consists of two, easily deployable, shipping containers, stacked on top of each other, to minimize footprint. The unit is easy to install. The only infrastructure required is electricity, compressed air, demineralised water, and of course, the flue gas. The captured CO<sub>2</sub> can be fed back to the flue gas stack, or it can be compressed to demonstrate utilization options.

CapsolGo™ comes with an all-inclusive package: transport, installation, deinstallation, operation, and testing by an independent party. CapsolGo™ offers many advantages for industrial emitters, including:

1. Experience the CO<sub>2</sub> Capsol's energy-efficient technology to verify the effectiveness of the Capsol EoP™ technology before investing into a full-scale application.
2. The Capsol EoP™ technology utilises the proven, environmentally friendly solvent potassium carbonate. An increasing number of industrial facilities have heard about potassium carbonate and understand the many advantages of it, like lower capture and material costs. Potassium carbonate is widely available and there are no harmful emissions.
3. During a CapsolGo™ campaign, the plant's specific flue gas and operation is tested to define an optimal solvent blend for the full-scale carbon capture plant.
4. CapsolGo™ is a powerful tool to demonstrate safe carbon capture to stakeholders. Operation and maintenance teams can get familiar with CO<sub>2</sub> Capsol's technology and prepare for the full-scale operation. The public, such as residents, can experience the environmentally friendly carbon capture solution live, in person.

With an independent test report, plant owners will be able to accelerate their decision processes towards the full-scale plant and enhance the quality of their soft funding applications.

With a capture capacity of several hundred tonnes of CO<sub>2</sub> per year, CapsolGo™ enables maximum insights about the technology, while at the same time making it affordable for industrial emitters to test carbon capture at their plant.





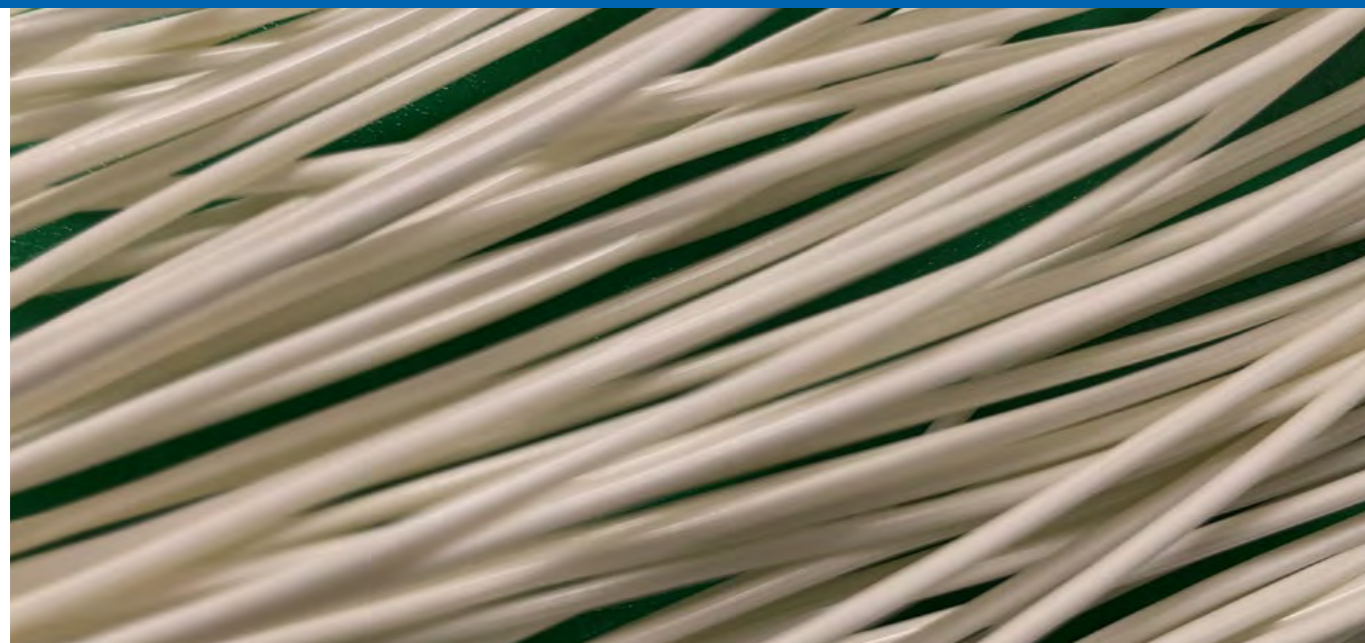

## SUMMARY

Decarbontek LLC (Decarbon) has developed a novel class of next-generation solid polymeric sorbent fibres and devices for direct air capture (DAC), and point of source carbon capture applications. The novel class of sorbent fibres are manufactured by a novel industrially feasible phase inversion process, utilizing widely available inexpensive raw materials.

These sorbent fibres are mechanically strong, exhibit high surface area, high CO<sub>2</sub> sorption capacity, low regeneration heat and temperature. The sorbent fiber devices are constructed with controlled packing density to minimize the pressure drop. Decarbon's sorbent fiber devices are suitable for passive direct air capture and can significantly decrease the carbon capture costs. Decarbon's novel sorbent fibres and devices are protected by a series of pending patents.

## BENEFITS

Compared with the conventional solvent-based absorption and adsorption processes, the CCUS processes utilizing Decarbon's novel solid sorbent fibres exhibit following advantages.

- Lower CapEx and OpEx due to low sorbent cost and regeneration energy
- No solvent emissions
- No need for make-up water due to evaporation
- No corrosion
- Modular construction, ready to scale
- Insensitive to water content in the feed, no need for humidity control

## DESCRIPTION

CCUS is essential to achieving the net-zero objective, and the key to large scale deployment of CCUS is a low-cost separation process to purify CO<sub>2</sub> from a gas stream containing very low CO<sub>2</sub> concentration. Currently, CO<sub>2</sub> separation accounts for about 80% of the total CCUS cost. The primary technology utilized today is the solvent-based absorption process. In addition to the high cost of solvent regeneration, the solvent-based process also suffers from solvent and water losses, high corrosion to the equipment and results in bulky unit operations.

Solid sorbent technology has been sought-after due to its low regeneration energy requirement. Significant amount of development work has been carried out to prepare sorbents by loading amines onto the porous supports, such as silica, carbon and molecular sieves. Due to the limitation of pore structure of the supports, often a low molecular weight amine is used, which is prone to be lost in the regeneration step, either due to the evaporation or oxidation, or the formation of urea. High molecular weight polyamines can overcome all of these issues. In addition, inorganic sorbents often suffer from attrition and high pressure drop.

To overcome all the issues mentioned above and to provide a low-cost solution for CCUS, Decarbon has developed a novel class of next-generation solid polymeric sorbent fibres. These sorbent fibres are manufactured by a novel one-step phase inversion process, a process similar to a membrane manufacturing process. All raw materials are widely available on commercial scale and are low costs. These sorbent fibres are mechanically strong, exhibit high surface area, have high CO<sub>2</sub> sorption capacity, and low regeneration heat and temperature. Decarbon also designed and filed patent applications for the sorbent fiber devices that can be conveniently utilized for small or large gas streams and up to Gt CO<sub>2</sub> scale. The fibre packing density can be controlled by a computer-controlled winding. Decarbon's sorbent fiber devices are suitable for passive direct air capture (DAC) under all air humidity levels and all weather conditions and can significantly decrease the DAC cost.

Decarbon's novel sorbent fibres and devices are protected by a series of pending patents, ranging from fiber preparation to device design and utilization.

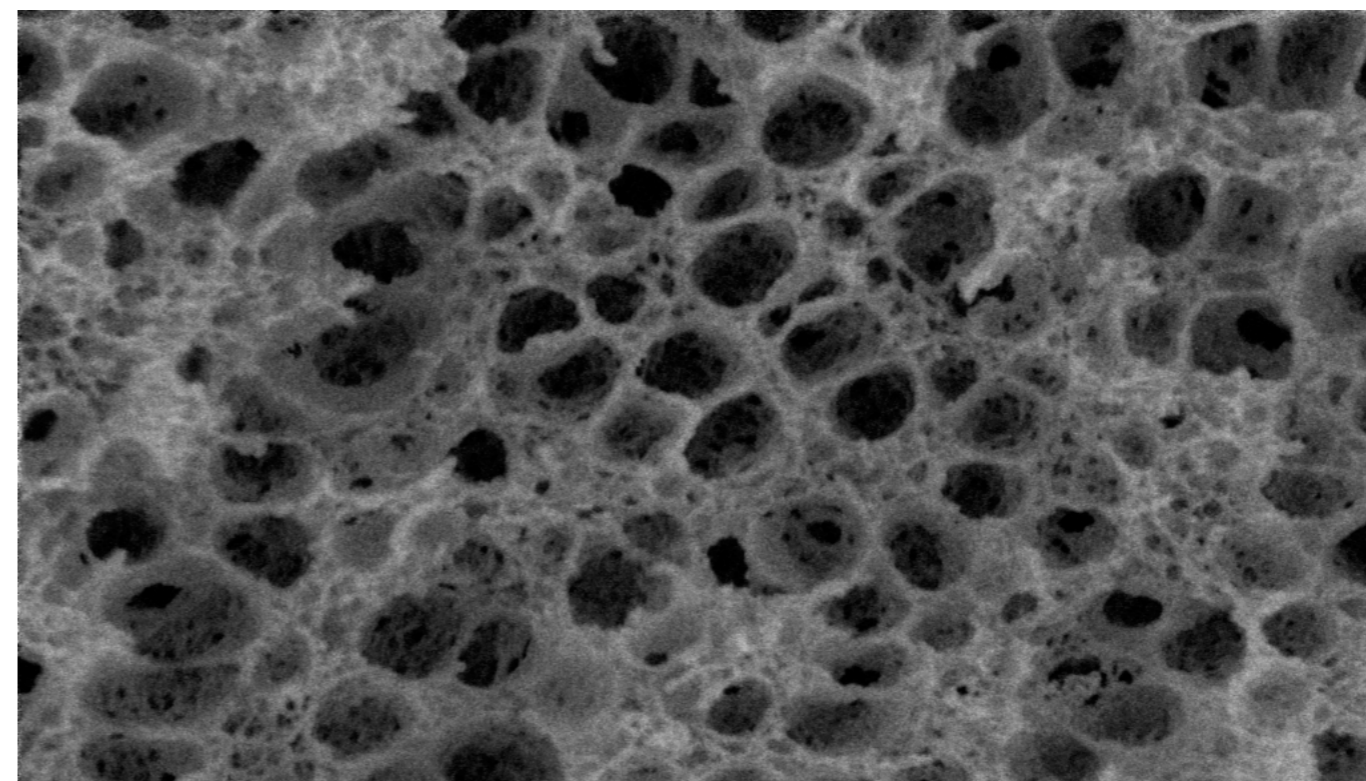



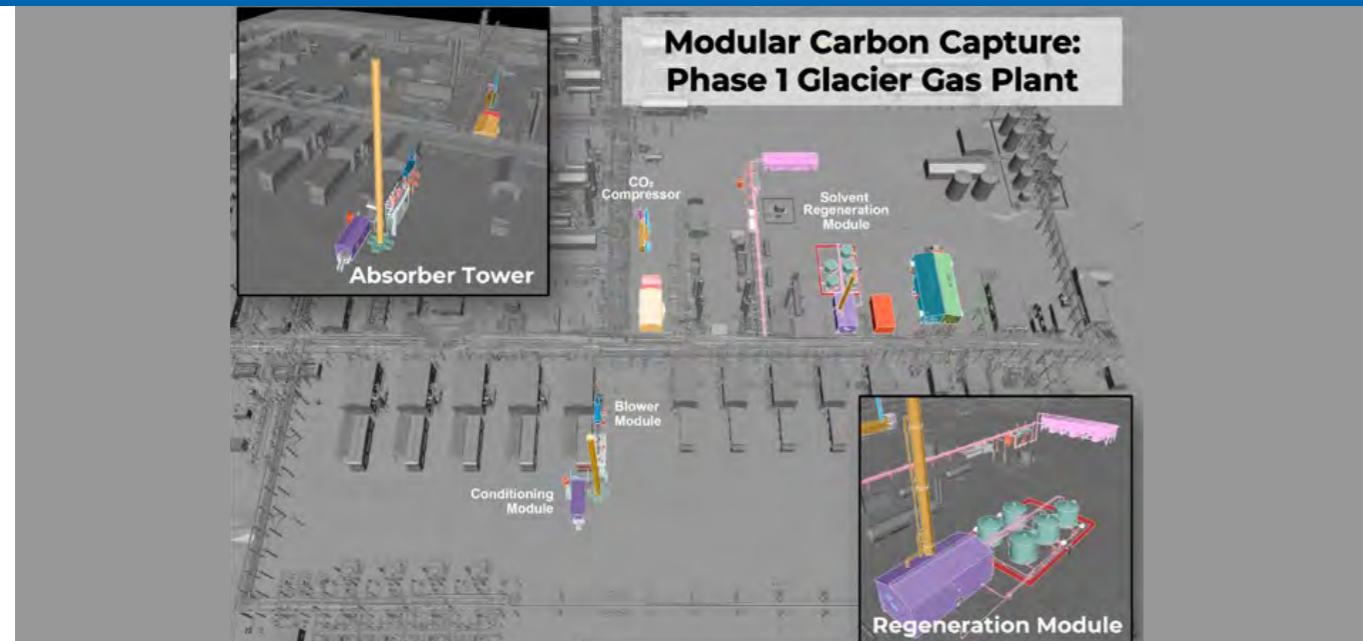

**SUMMARY**

Entropy Inc. is a global leader in post-combustion carbon capture and sequestration project development, with a full suite of proprietary state-of-the-art technology, in-house engineering and subsurface technical teams, and approximately 1.8 Mtpa CO<sub>2</sub> of projects under development. Entropy's first commercial project, which is designed to capture and store approximately 0.2 Mtpa CO<sub>2</sub> in 2 phases from gas-fired compressor engines, began construction in 2021 and the first phase (0.05 Mtpa) will be commissioned in Q2 2022. Entropy technology was

developed in partnership with a team from the University of Regina's Clean Energy & Technology Research Institute, using a world-renowned carbon capture testing facility. The product of this multiyear collaboration is a low-cost CCS system using innovative modular carbon capture (MCCSTM) technology and a novel, high-performance solvent (Entropy23™), capable of abating CO<sub>2</sub> for less than CAD 50/t CO<sub>2</sub> for both retrofit and new equipment projects.

**BENEFITS**

- **Low Cost:** Break-even carbon price (achieving 10% rate of return on capital investment) less than CAD 50 as being demonstrated by the Glacier CCS project in Alberta, Canada
- **Innovative:** Combining modular technology with heat capture and high-performance carbon capture solvents unlocks never-before-seen CCS methodology
- **Scalable:** Entropy's technology enables emitters to quickly implement post-combustion CCS in a phased approach with minimal initial costs, and increase scale gradually
- **Retrofit:** Entropy's modular carbon capture technology can be retrofitted to facilities of existing emitters, without the need of plant expansion
- **Proven:** Entropy's team has decades of post-combustion CCS experience, and the first gas-fired project underway.

**DESCRIPTION**

Entropy has created a post-combustion CCS system, which makes use of proven technology that has been improved and adapted specifically for carbon. Entropy's proprietary, build-for-purpose technology is unrivalled with respect to efficiency and cost and with modular building technology, and is available to small and mid-sized emitters.

Entropy's CCS system is highly efficient and derives net negative carbon on an operational basis (Scope 1&2). Carbon emissions are reduced by more than 80% relative to pre-CCS carbon emissions, net of the carbon generated in Entropy's process.

Entropy has partnered with CETRI (Clean Energy and Technical Research Institute) from the University of Regina to commercialize technology that has been under development for decades by an internationally renowned team of experts. Entropy has developed a CCS system, which includes process improvements and an advanced high-performance solvent that has demonstrated material performance improvements relative to traditional solvents. Entropy23™ outperforms traditional CCS solvents and requires fewer heat inputs resulting in an energy and cost-efficient process.

The initial commercial application of Entropy's technology is currently under construction at the Glacier Gas Plant near Grande Prairie Alberta, with start-up planned for

Q2/22. This post-combustion CCS facility will capture approximately 0.05 Mtpa CO<sub>2</sub> in Phase 1 and will provide real-world data to backstop extensive testing. Phase 2 of the project is scheduled to come on-stream in 2023 and will capture an incremental 0.15 Mtpa CO<sub>2</sub>.

The efficiency gains Entropy has achieved results in overall carbon capture costs of approximately CAD 50/t CO<sub>2</sub>. This technology is applicable for multiple types of post-combustion projects across a range of sizes and industries. Entropy has a planned capital program of approximately \$250 million per year to build CCS facilities in exchange for environmental attributes related to the carbon capture projects. The Company is also pursuing a technology licensing strategy.

Entropy is currently working to adapt its CCS system to a variety of emission sources with a total project inventory of 1.8 Mtpa CO<sub>2</sub>. Modular construction techniques employed by Entropy result in reduced construction time, project risks and costs.

The Entropy team is highly skilled in engineering, project and regulatory management and has extensive subsurface experience injecting CO<sub>2</sub>, acid gas and industrial waste fluids underground while meeting the highest regulatory standards.

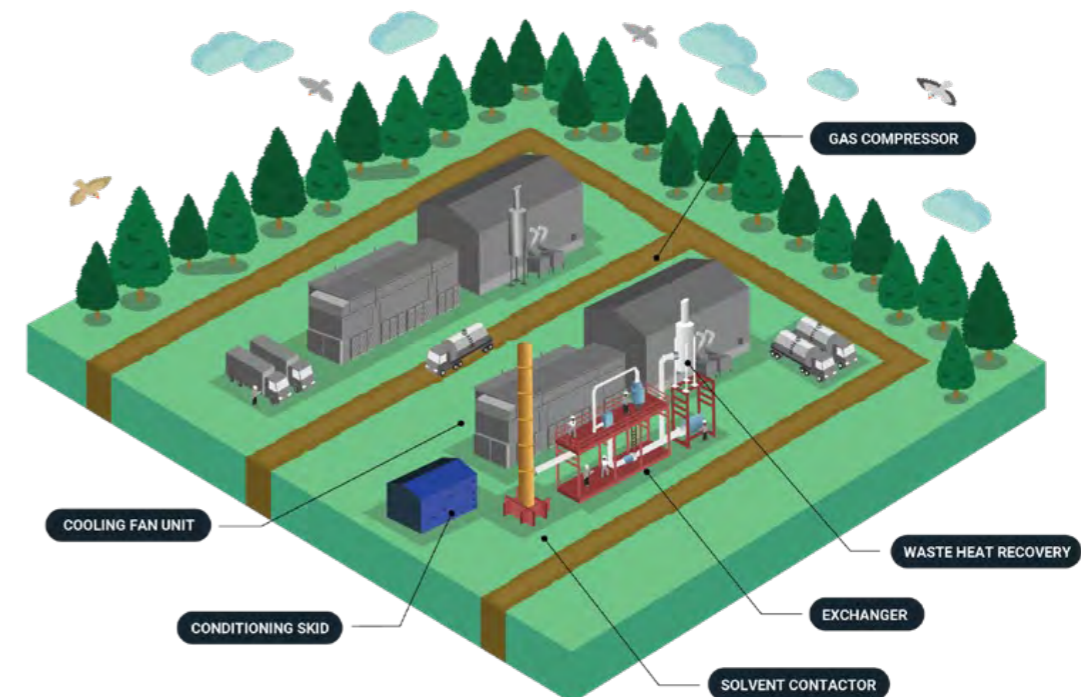





**SUMMARY**

**A path to Carbon Neutrality starts today**

With a global focus on combatting climate change, industry leaders are aggressively seeking technology solutions that limit greenhouse gas emissions.

This is especially critical for carbon-intensive industrial markets such as power, steel, cement, refining, petrochemicals, hydrogen and natural gas processing where reducing environmental impact has been difficult.

There are many avenues a company can take to meet sustainability goals – and a drive towards carbon neutrality is gaining prominence as a key driver of meeting commitments. While many companies are taking the first steps towards carbon neutrality with more energy-efficient machinery and processes, technology supporting these initiatives is continuously evolving and improving, and companies need to keep up.

**Carbon Capture Technologies and their role in sustainable operations**

Deciding what sustainability initiatives to implement to start your company’s journey towards more environment-friendly processes can be daunting. From making commitments to plant a certain number of trees to implementing energy-efficient processes, there are multiple pathways leading towards more carbon-neutral operations, some of which can be integrated immediately, but others require longer-term planning.

Carbon capture, utilisation and storage (CCUS) is a key technology for reducing greenhouse gas emissions. According to the International Energy Agency, carbon capture capacity must increase more than 20 times to enable the capture of 840 Mtpa CO<sub>2</sub> by 2030 to meet global emission goals.

Incorporating carbon capture technologies into production is an effective path industrial companies can take to reduce their environmental impact and prevent harmful emissions from entering the atmosphere. However, carbon capture is a broad and complex field, requiring in-depth knowledge of both the technology and industry to effectively execute.

**BENEFITS**

**Reduce CO<sub>2</sub> emissions in hard-to-abate industries**

At Honeywell, our CO<sub>2</sub> solutions can help make an impact within a wide range of industrial market segments where decarbonization has been a proven challenge, such as:

- Power
- Steel
- Cement
- Refining
- Petrochemical
- Hydrogen Plant
- Natural Gas Processing

**CHALLENGES FOR INDUSTRY LEADERS**

- National and corporate net-zero policy ambitions
- Legal, regulatory, and financial frameworks are progressing
- Large scale projects remain a significant hurdle due to energy requirements
- Full ecosystem that embodies all elements of carbon capture to support fast-moving projects

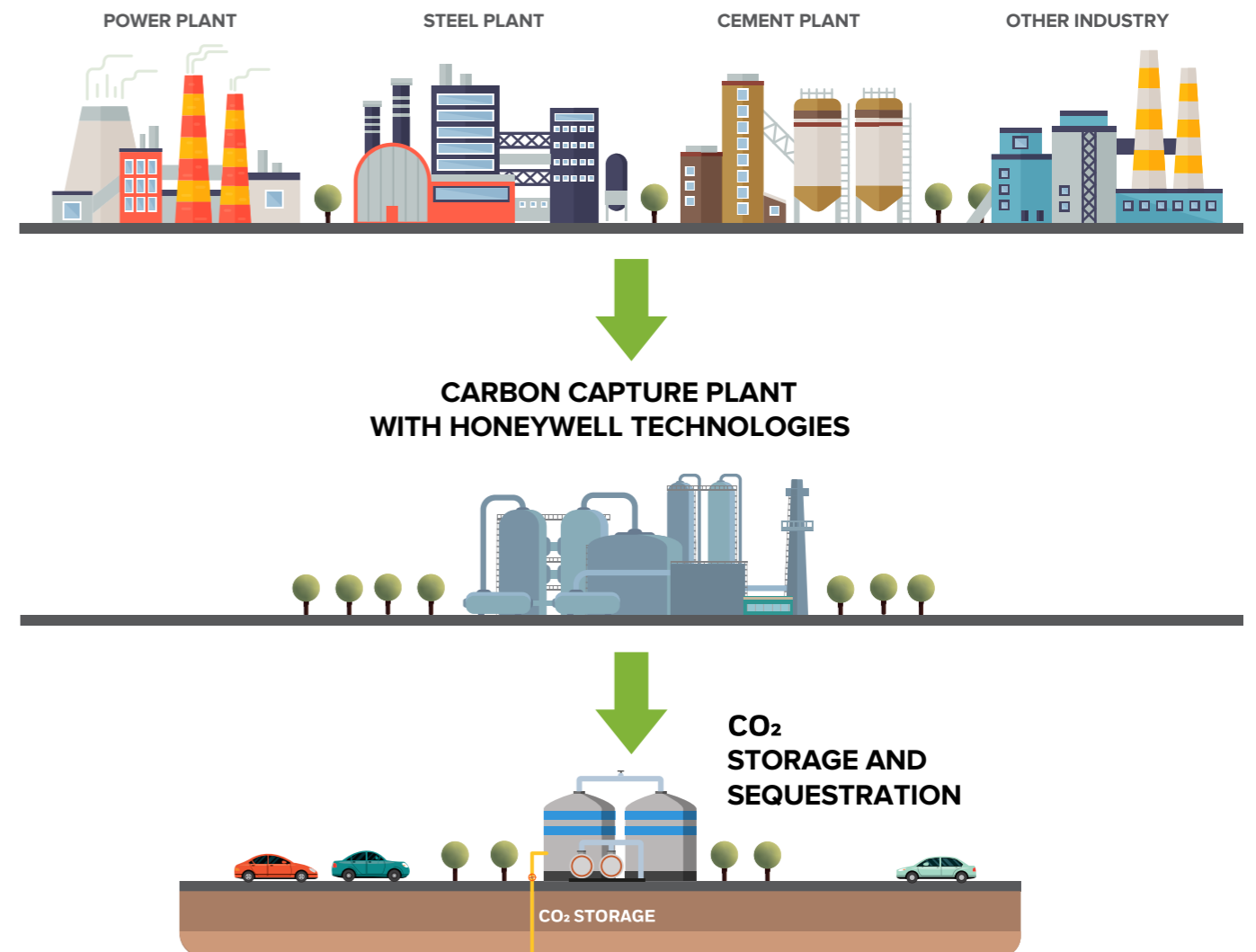



## DESCRIPTION

### Your experienced provider of carbon capture solutions

At Honeywell, we're uniquely qualified to support industrial sectors with implementing carbon capture technology into their operations. With more than 70 years of experience in carbon capture, we have the knowledge to help you progress your journey to carbon neutrality.

We offer a proven suite of solvent, membrane, adsorbent and cryogenics technologies with industry-leading capture of CO<sub>2</sub> emissions. Honeywell CO<sub>2</sub> solutions are already capturing 15 Mtpa CO<sub>2</sub> worldwide with additional installed capacity ready to do more.<sup>1</sup>

### Significant track record in Carbon Capture with vast technology portfolio

Honeywell has a vast portfolio of carbon capture technologies that help support industry leaders to move towards a lower carbon footprint. Our team of experts can work with you to determine the best solution to meet your CO<sub>2</sub> emission goals.

### Chemical Solvents

#### AmineGuard™ & Amine Guard FS Process

Largest licensor of high concentration MEA-based systems; formulated solvents have low OpEx compared to MEA (>600 units)

#### Benfield™

Inorganic solvent for pressurized flue gas & industrial processes (>650 units)

#### Advanced Solvent for Carbon Capture

Direct CO<sub>2</sub> capture from flue gas for power, steel, cement, natural gas, refining & petrochemical industries.

### Physical solvents

#### SeparALL™ Process

H<sub>2</sub>S/CO<sub>2</sub> selectivity using Selexol solvent for sources containing sulphur in oxidative conditions (>50 units)

### Adsorbents

#### Polybed™ Pressure Swing Adsorption (PSA) System

Optimized adsorbents and cycles for CO<sub>2</sub> rejection (>1100 units, 3 operating in CO<sub>2</sub> application)

### Cryogenics & Membranes

#### Separex™ Membrane Systems

High, partial-pressure CO<sub>2</sub> capture, significant experience in offshore capturing and sequestering (>300 units)

#### Ortloff CO<sub>2</sub> Fractionation

Captures CO<sub>2</sub> and also provides it as a high-purity liquid product

### Post-combustion advanced solvent technology unlocks potential

In collaboration with the University of Texas, Honeywell is proud to offer a new advanced solvent technology to lower CO<sub>2</sub> emissions generated from combustion flue gases in hard-to-abate industries, such as power, steel, cement, refining, petrochemical and other industrial plants.

Utilising an advanced solvent, this point source CO<sub>2</sub> removal technology enables CO<sub>2</sub> to be captured at a lower cost through greater efficiency using smaller equipment. This creates viable project economics today as countries across the globe progress to meet their sustainability targets.<sup>2</sup> It can be retrofitted within existing plants or included as part of a new installation.

### A carbon neutral future starts today

Meeting future sustainability goals requires action now. Honeywell has the expertise and carbon capture technology portfolio available at scale today to help you on your journey to carbon neutrality.

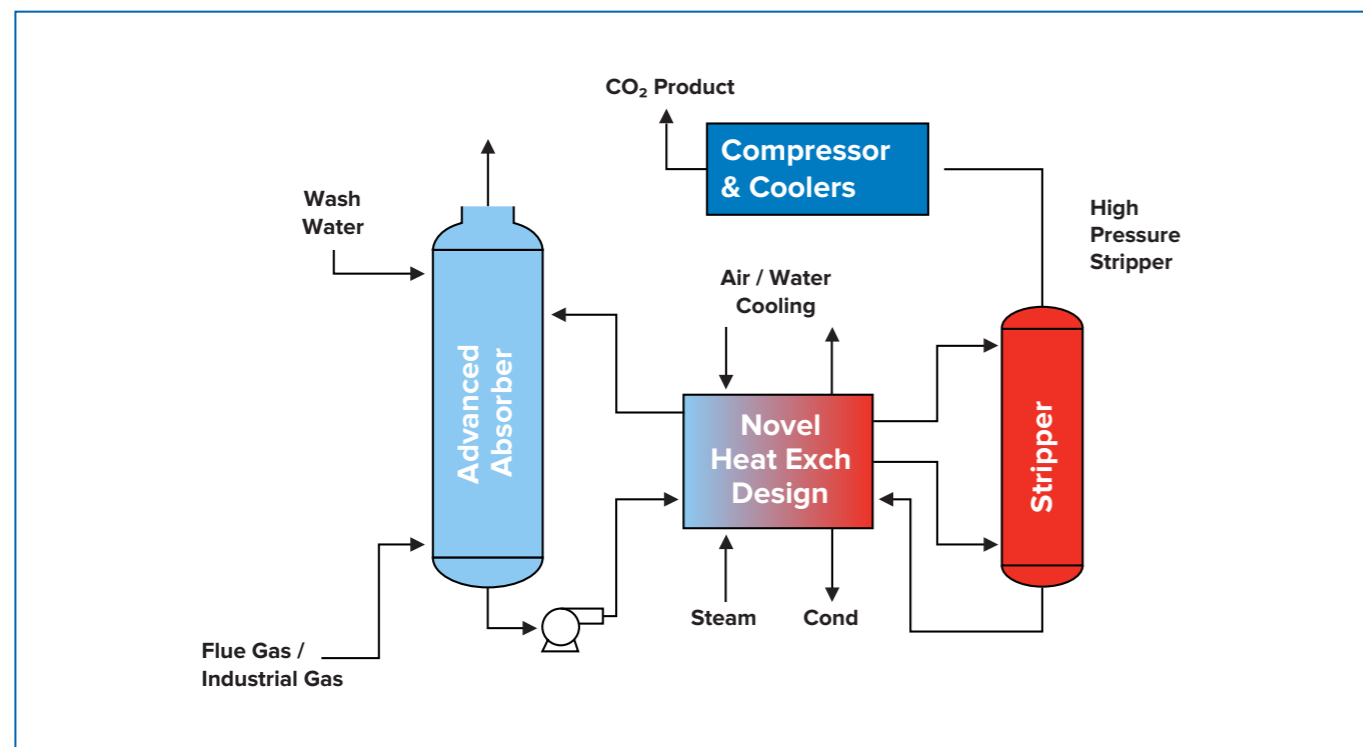

Honeywell can provide technology as initial studies to define best path forward, transfers the technology through license, engineering and modular supply.

<sup>1</sup> Includes capacity of deployed Honeywell technology (membranes, chemical and physical solvents) in installed projects enabling CO<sub>2</sub> capture from gas streams, of which 15 million tons of the captured CO<sub>2</sub> is being utilized for enhanced oil recovery annually.

<sup>2</sup> Lower cost of CO<sub>2</sub> capture based on comparing estimated capital and operating costs of this solution against other conventional amine solvents in same applications. CO<sub>2</sub> pricing considers current policies of \$50/ton tax credit (USA per IRS Section 45Q for permanent storage) and \$60/ton (UK and Europe – approximate averages from August 2021 through country/regional Emission Trading Systems and as reported by IHS Markit).





**SUMMARY**

Post combustion capture technology (chemical absorption) can be applied to various flue gas. Captured CO<sub>2</sub> using chemical absorption can be applied to CO<sub>2</sub> utilization and storage.

**Outline of Chemical Absorption**

- The flue gas from a power plant contacts a solvent in the CO<sub>2</sub> absorber. The solvent selectively absorbs the CO<sub>2</sub> and is sent to the CO<sub>2</sub> stripper. In the stripper, the CO<sub>2</sub>-rich solvent is heated to release almost pure CO<sub>2</sub>.
- The CO<sub>2</sub>-lean solvent is then recycled to the absorber.

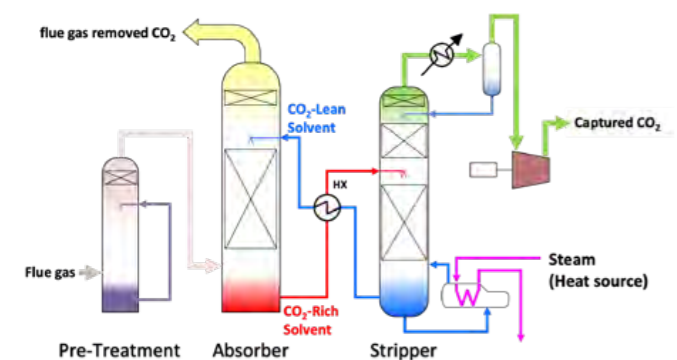

**CO<sub>2</sub> source and utilization/ storage**

IHI has not only CO<sub>2</sub> capture technology, but also works with utilization technologies, such as methanation and olefin production.

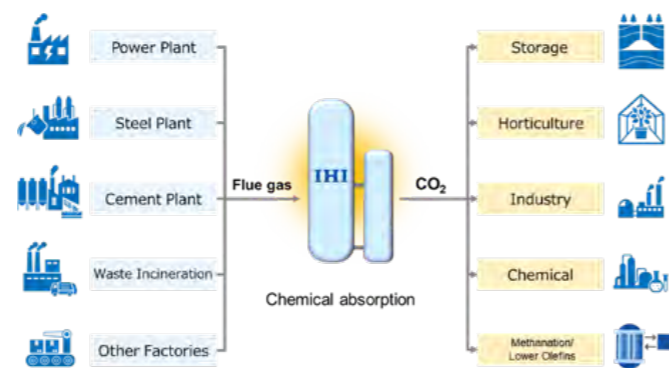

**BENEFITS**

- Specially designed to recover CO<sub>2</sub> from low-pressure, oxygen-containing streams, such as the flue gas of power plant.
- Applicable to both the existing and new power plants and providing CO<sub>2</sub> purity in excess of 99%.
- Adapting to customer's demand for both full and partial CO<sub>2</sub> capture with module design.
- Providing sequential build up of CO<sub>2</sub> capture capacity.
- Minimizing energy requirement for CO<sub>2</sub> capture using developed technologies.

**DESCRIPTION**

**Pilot Plant**

**20 t-CO<sub>2</sub>/d Pilot Plant**

- Developed original solvent, packing and system
- Achieved approximately 40% higher energy efficiency

Specifications

Location	IHI's AIOI Works in Japan
Source Gas	Flue Gas of Coal-Fired Boiler or Propane Gas Boiler
Captured CO <sub>2</sub>	20 t-CO <sub>2</sub> /d
CO <sub>2</sub> Capture Ratio	>90%

**PICA (Post-combustion carbon capture, IHI, CSIRO, AGL) Pilot Plant**

- Demonstrated by using actual flue gas from coal-fired power plant
- 5,000 hours operation successfully completed

Specifications

Location	Loy Yang A Power Plant In Australia
Source Gas	Flue Gas of Coal-Fired Boiler
Captured CO <sub>2</sub>	0.5 t-CO <sub>2</sub> /d
CO <sub>2</sub> Capture Ratio	>90%

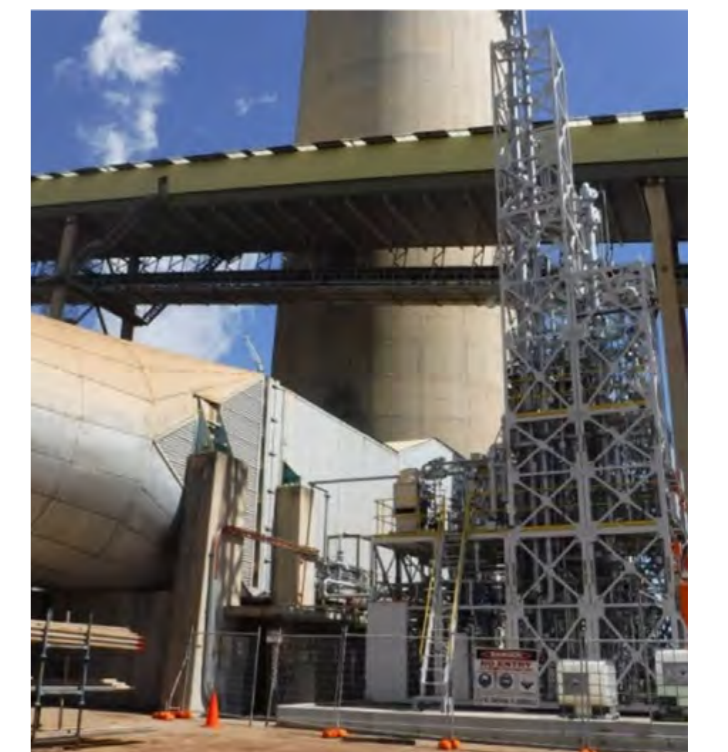



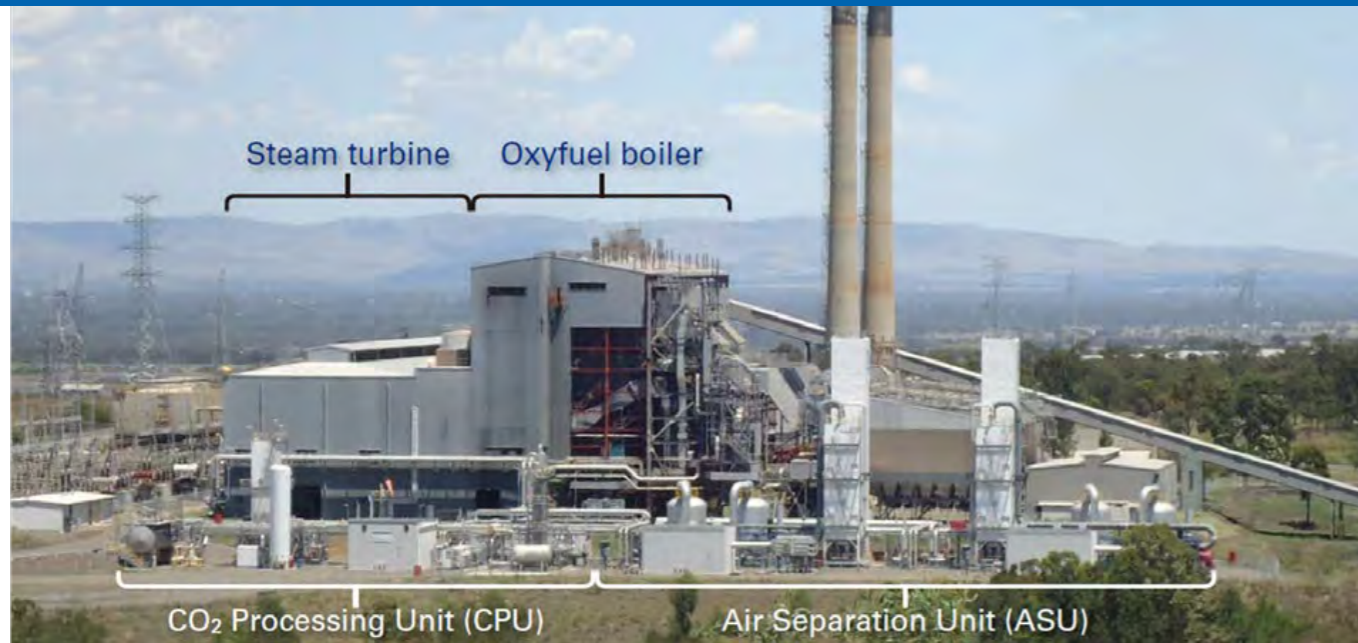

**SUMMARY**

Oxyfuel Combustion will convert fossil-fuel or biomass-fired plants into carbon-neutral or -negative with CO<sub>2</sub> utilization/storage by way of coping with the climate change issue, and will contribute to the environment and the economy of the community.

IHI is the only boiler company in the world to have applied the oxyfuel combustion technology to a thermal power plant and operated it for more than 10,000 hours.

Example of the application to coal fired power station -

**BENEFITS**

- Applicable to both existing and new plants.
- Achievable CO<sub>2</sub> capture rate of up to 98% and nearly zero emissions.
- Pure CO<sub>2</sub> through CPU can be obtained suitable for utilization and storage.
- Economical benefit by utilization and sale of byproducts such as N<sub>2</sub> separated in the ASU.
- Utilization of excess or surplus oxygen is possible.
- Energy storage using oxygen production is possible.

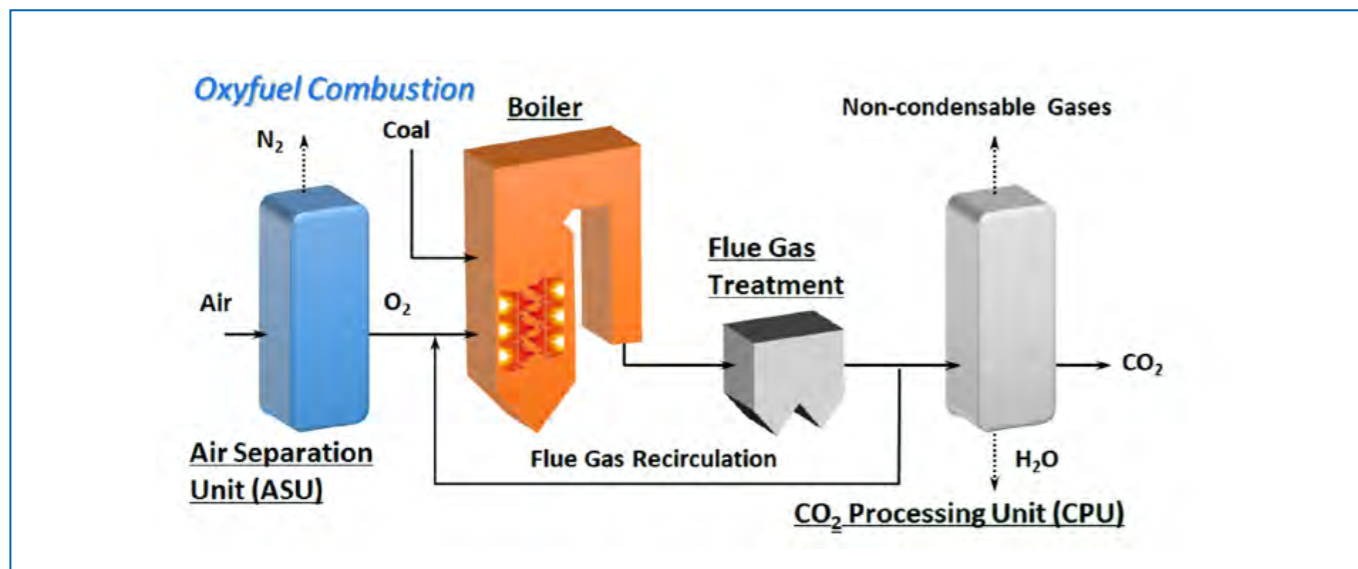

**DESCRIPTION**

**Callide Oxyfuel Project**

**Features**

- The world's first and only oxyfuel power plant;
- having all processes required for commercial use
- selling electricity by capturing CO<sub>2</sub>
- using existing old, not CCS-Ready, coal-fired power plant

Injection of captured CO<sub>2</sub> into the underground;

- the world's first injection from oxyfuel power plant

**Scope:**

- No. 4 Boiler refurbishment
- 2 x 330 TPD ASU
- Oxyfuel combustion Retrofit
- 75 TPD liquid CO<sub>2</sub> recovery
- Trucking to CO<sub>2</sub> reservoir
- Injection and monitoring

**Callide A Power Station**

- Owned by CS Energy
- 4 x 30 MW<sub>e</sub>
- Steam: 136 t/h at 4.1 MPa, 465 °C
- Commissioned: 1965 – 69
- Refurbished: 1997/98
- Placed in storage in 2002

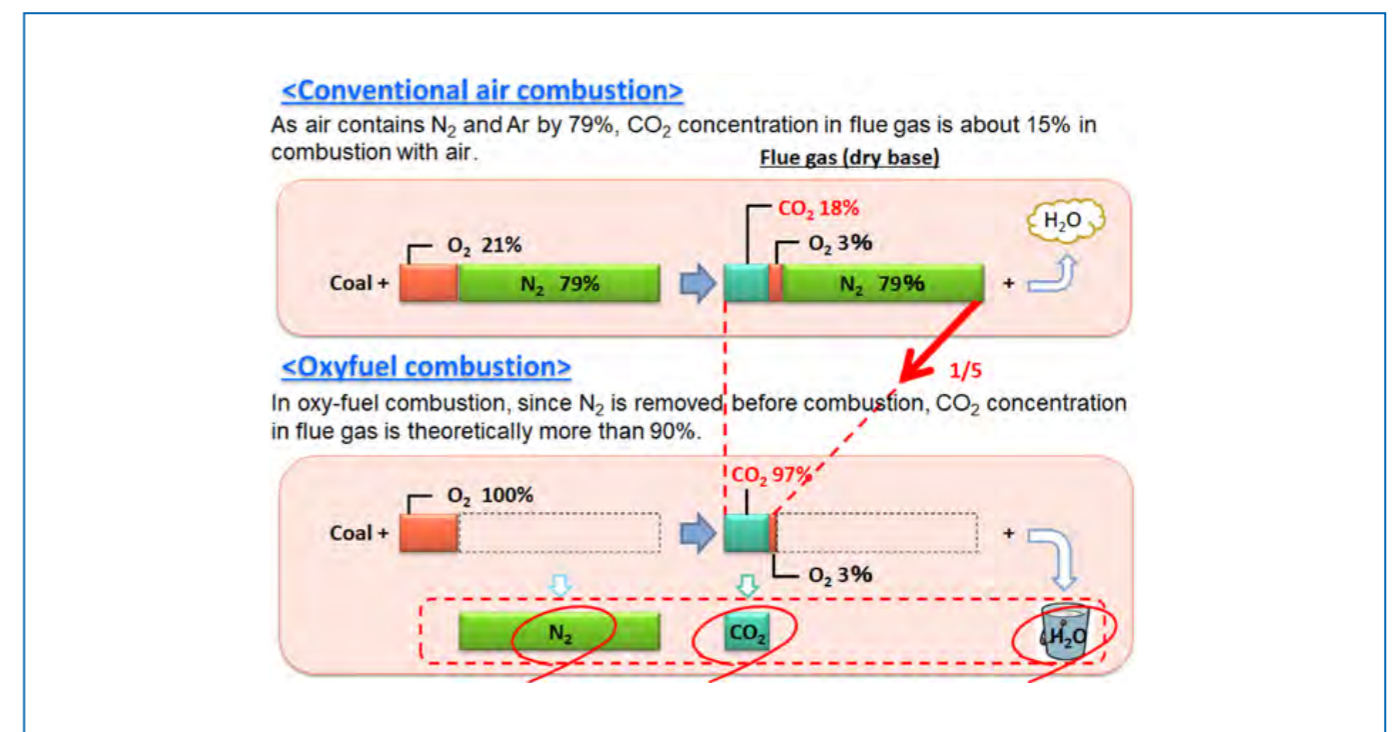





## SUMMARY

The LEILAC Group, a subsidiary of Calix Ltd., aims to apply a breakthrough in carbon capture technology that will enable the cement and lime industries to reduce their emissions dramatically - while retaining their international competitiveness – by capturing those process emissions at low costs. This is a completely new type of carbon capture technology: a process modification approach, rather than requiring additional chemicals or processes. The technology can also be retrofitted in a modular form at any

scale, and makes use of any fuel or energy source (such as biomass, hydrogen, or electricity) – providing a future proof solution.

The LEILAC2 project has passed its Final Investment Decision (FID) to build a plant capable of capturing 20% of a cement plant's CO<sub>2</sub>, and will be integrated into Heidelberg Cement's plant in Hannover, Germany. LEILAC2's modular design will form the basis for decarbonising a full plant.

## BENEFITS

- **Low Cost:** LEILAC2, as a first-of-a-kind modular retrofit, is aiming to ultimately separate CO<sub>2</sub> for a cost €20 - 25 per tonne of CO<sub>2</sub> avoided.
- **Addresses Unavoidable Emissions efficiently:** While there are challenges still to be overcome, the technology aims to have a minimal energy penalty – meaning there is a potentially low production abatement cost, and not just the capture cost.
- **Low-Impact Retrofit Integration:** The LEILAC2 plant is being designed to have minimal impact on the host plant, as a retrofit to a fully operational plant.
- **Energy Agnostic:** The technology is being designed to use any fuel or energy source, such as biomass, hydrogen, or electricity – with the intention of enabling plants to continue to transition to more sustainable, low-carbon fuels, and achieve net zero CO<sub>2</sub> emissions.
- **Scalable:** The technology is being designed in a modular fashion, to enable scaling to any plant size.
- **Efficient, global roll out:** The intent of the technology is to enable its rapid rollout through the use of local engineering firms.

## DESCRIPTION

The cement and lime industries play a vital role in our society. Cement is used in our roads, buildings, homes, offices and almost all infrastructure. Lime is used in a variety of applications, including the iron and steel, chemical, paper, pharmaceutical, drinking water, food, and farming industries. However, the cement industry alone is responsible for around 8% of global CO<sub>2</sub> emissions, as most of their emissions are inherent to the production process and are therefore difficult to avoid. The latest IPCC report concluded that the world has just eight years to get emissions under sufficient control. "It's now or never...without immediate and deep emissions reductions across all sectors, it will be impossible." IPCC Working Group III Co-Chair.

The LEILAC technology is a new type of carbon capture technology, designed to address the unavoidable CO<sub>2</sub> process emissions from the cement and lime industries. The design involves a process modification approach, rather than requiring additional chemicals or processes, and therefore, can separate CO<sub>2</sub>. It uses externally heated tubes that keep the CO<sub>2</sub> released during the manufacturing process pure and not contaminated by flue gases or air, and so – as a capture technology - does not need the significant additional energy to separate gases from gases required for most other approaches.

Supported by the European Union's Horizon 2020 scheme, the LEILAC1 and 2 projects have been proving, developing and scaling up this concept. LEILAC2 was established to demonstrate that the Calix technology can be retrofitted to be capable of capturing 20% of a cement plant's emissions; be integrated without causing major issues or interruptions to the host plant; investigate the use of alternative fuels; and be a replicable module enabling scale up. Since the project commenced in 2020, as a global society, we have faced significant challenges: resulting in delays and price increases across the supply chain. Nevertheless, the project team – involving talented individuals from all of the project partners - have managed to develop a cost-efficient and technically viable design. The project successfully passed its Financial Investment Decision (FID), and will now proceed into detailed design phase through 2022, followed by procurement and construction of the plant itself (with flag gates to deal with risks, particularly the current market volatility).

LEILAC2 – despite being a 1st of a kind demonstration retrofit – has the potential to make a step-change in industrial decarbonisation. Including expected compression, fees and, CapEx costs – this equates to an avoidance (not just capture) cost of around €20-25 per tonne. This is an R&D plant, with associated risks, but will deliver a replicable module that will be a step change in addressing a plant's emissions cheaply.

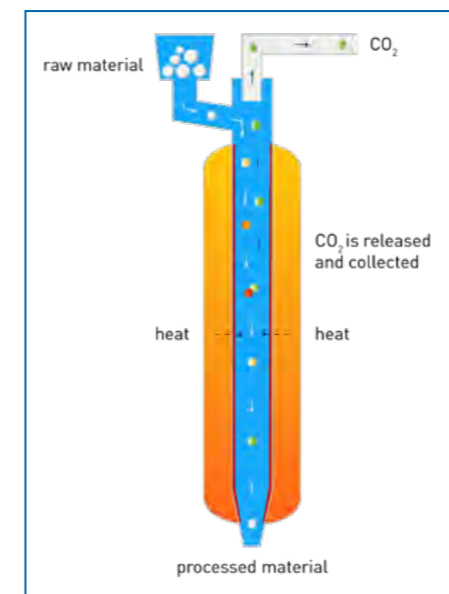





## SUMMARY

In the next five minutes of reading this article, human activities will add approximately 300,000 tonnes of CO<sub>2</sub> to the biosphere that supports all life forms. Carbon dioxide (CO<sub>2</sub>) is a powerful greenhouse gas (GHG). Climate change events such as droughts, floods or uncontrolled fires are more frequent, putting vulnerable populations and ecosystems at risk. Scientists and civil authorities recognize that the pace of GHG production is unsustainable. Legislators impose new rules to curb emissions. Progressive industrial leaders want to act without delay, as they acknowledge that their future business is in a symbiotic relationship with the environment. GHG abatement is the goal of a generation, so it is not the last.

Tensions between business-as-usual commercial imperatives, more stringent regulations and the pressure to act within the next capitalization cycle in an undiscovered competitive landscape put an immense burden on the industry, specifically in sectors with unavoidable CO<sub>2</sub> emissions.

The past is an enlightening source of insight to secure the best path forward. SAIPEM's rich history offers a glimpse of hope. Since 1957, the Milan-based global solution provider has been delivering complex projects worldwide in 72 countries with 35,000 dedicated project and technology experts.

SAIPEM has vast and lengthy experience managing carbon dioxide throughout the Carbon Capture, Utilization and Storage (CCUS) value chain.

SAIPEM designed and built many of the world's most remarkable gas treating projects in numerous applications such as natural gas processing, syngas treating, hydrogen, methanol, ammonia and urea synthesis, to name just a few.

SAIPEM erected significant infrastructures to transport gasses and liquids in 130,000 km of pipeline projects throughout all geographies.

Many of the 7,000 wells that SAIPEM drilled over land and water have been used to re-inject or sequester acid gas and CO<sub>2</sub>.

Finally, through its intimate knowledge as engineering, procurement and construction (EPC) contractor and as the urea technology provider of 140 fertilizer projects, SAIPEM developed expertise and know-how with many carbon capture technologies, such as processes based on amines and carbonates, as well as distinctive competencies in the compression of CO<sub>2</sub> from atmospheric to supercritical pressures and re-use of CO<sub>2</sub> in urea and methanol products.

SAIPEM has been looking to find the best second-generation process to reduce costs and environmental liabilities associated with predominant amine-based technologies. In 2019, SAIPEM acquired a disruptive and innovative technology from CO<sub>2</sub> Solutions Inc. (CSI), now marketed as "CO<sub>2</sub> Solutions by SAIPEM", which uses an aqueous carbonate solution catalysed by an enzyme. It improves a proven scheme with carbonates to catch CO<sub>2</sub> with a salt and protein water solution.

The enzyme is a Carbonic Anhydrase (CA) tailored to perform under industrial process conditions and produced affordably in large quantities. CA catalyses the hydration and dehydration of CO<sub>2</sub>, attaching and removing a water molecule to CO<sub>2</sub> by accelerating the reaction rate up to 1 million times per second – one of the fastest catalytic reactions in nature!

Many different forms of CA exist in nature as they are present in all animals and all plants. If you breathe, you are

exploiting the benefits of carbonic anhydrase, as it is used by your body to expel CO<sub>2</sub> from your lungs and perform other biological functions. CA is as old as life on this planet. The innovation is to use CA in an industrial process.

The carbonate system acts as a CO<sub>2</sub> carrier by forming bicarbonates, gets transformed back into carbonate by exhaling the CO<sub>2</sub>, similar to in our lungs. The technology has the nickname "Industrial lung™" for this reason.

## BENEFITS

There are many advantages of using a carbonate system compared to other carbon capture technologies.

- In post-combustion application, salt systems are less sensitive to oxygen, sulphur and nitrogen oxides, which can significantly degrade amine systems. This avoids, in most instances, the need to remove SO<sub>x</sub> and NO<sub>x</sub> from the flue gas before carbon capture.
- The water-based salt system's low volatility does not create aerosols that must be mitigated and controlled.
- The enzymatic process does not use or generate any toxic compounds, which reduces environmental liabilities compared to other technologies and avoids secondary containment.
- The process does not create sludges or solid wastes that require a reclamation system to be recycled back into the solvent.
- Finally, the enzymatic carbonate technology is regenerated with low-temperature residual heat at 85 °C.

All these benefits reduce the capital and operating costs.





## DESCRIPTION

The enzymatic carbon capture technology developed by CSI over the last 20 years is very classical in its form from a gas treating point of view. The process starts with a conditioning step where the raw gas is cooled down to between 20 °C and 40 °C. Fine particulates are removed, and water vapour is condensed. The flue gas then flows into an absorption column at near atmospheric pressure, where the rising flue gas is comingled with a cascading liquid solution that gets loaded with CO<sub>2</sub>. The last step is a stripping column where the CO<sub>2</sub> is expelled from the liquid and captured, and the solution is regenerated and sent back to the absorption column.

Secondary systems to the primary process include the CO<sub>2</sub> compression cycle, the additions of enzyme and carbonate, the waste heat collection, and the condensate handling system.

The Technology Readiness Level (TRL) of the enzymatic process has progressed to TRL-8 with the first commercial start-up in 2019. This unit is getting its flue gas from a lime kiln in a Kraft pulp mill and delivers up to 30 tonnes per day of CO<sub>2</sub> to an adjacent greenhouse. The operation of this small commercial unit revealed vital points to consider for the industry:

1. The lime kiln's dusty gas stream has compositional similarities to cement kiln emissions.
2. The process is regenerated 100% with low-grade residual heat from the host plant at 85 °C, which has no impact on the host plant's heat balance, and this comes at no cost to the carbon capture process.
3. The capture unit produces CO<sub>2</sub> purity that surpasses greenhouse grades and any sequestration grade without additional efforts.
4. The power consumption of the system is low.
5. The enzyme's sustained performance is economically viable, and the OpEx competes favourably well with other amine technologies.
6. As all the process equipment used is standard in gas treating, the process blueprint and architecture are easily scalable to much larger sizes.

SAIPEM intends to quickly scale up the disruptive process to a size adapted to the industry's needs. As SAIPEM designs and delivers the largest gas treating units globally across its portfolio, it sees the scale-up does not present any technological concerns or insurmountable engineering challenges.

In the broader context of CCUS, SAIPEM has the track record, expertise, and know-how to integrate technologies and deliver systems beyond the scope of capture, i.e., in the capture – transport – storage – utilization value chain. Moreover, SAIPEM typically offers projects in lumpsum turnkey mode, which can help accelerate the attainment of carbon neutrality.

If the past is an enlightening source of insight to secure the path forward, rely on SAIPEM to abate your GHG emissions, deliver CCUS projects and accompany your energy transition.







## SUMMARY

Shell Catalysts & Technologies offers two leading, amine-based, high-capacity carbon-capture technologies, CANSOLV™ CO<sub>2</sub> Capture System and ADIP™ ULTRA, that are robust and proven, and have established records of performing cost-effectively in a wide range of industries.

Shell's CANSOLV™ CO<sub>2</sub> Capture System captures up to 99% of the CO<sub>2</sub> from post-combustion streams while Shell's ADIP™ ULTRA technology captures CO<sub>2</sub> from high-pressure, pre-combustion process streams, for example, from hydrogen manufacturing units, chemical plants and natural gas treating plants.

As a standalone, low-pressure, CO<sub>2</sub>-capture technology, the CANSOLV™ CO<sub>2</sub> Capture System is well-suited for retrofitting to existing plants and can also be included in greenfield developments. It uses a regenerable proprietary amine to capture CO<sub>2</sub> that is released as a pure stream, which makes the technology highly suitable for CCS projects.

Following technical and economic evaluations, capturing CO<sub>2</sub> from flue gas using the CANSOLV™ CO<sub>2</sub> Capture System may emerge as the preferred option because of the key features such as:

- CO<sub>2</sub> purity: The pure CO<sub>2</sub> product enables CCS or utilisation downstream of the plant.
- Adaptability: The standalone system is highly

adaptable to retrofit scenarios and greenfield projects, and a wide variety of industrial applications, gas flow rates and CO<sub>2</sub> concentrations. Units have been designed for CO<sub>2</sub> concentrations from 3.5 to 27% and treating gas flow rates from 11,000 to 4,500,000 Nm<sup>3</sup>/h.

- Asset integrity: The system has been designed for reliability through its high turndown capacity and the solvent's resistance to oxidative and thermal degradation.
- Low waste: The process uses a regenerable solvent, so very little waste by-product is generated, which can reduce project costs as the effluents are minimal.
- Low operating costs: The system offers cutting-edge performance. For example, its low parasitic energy consumption, fast kinetics and low volatility help to reduce the cost of operation and amine consumption.
- Track record: The technology is proven in large-scale CCS applications, having captured more than 4.5 Mtpa CO<sub>2</sub> from a power station flue gas in Canada since its start-up in 2014.

## BENEFITS

The CANSOLV™ CO<sub>2</sub> Capture System can capture up to 99% of the CO<sub>2</sub> from post-combustion streams and is proven for CCS at a 1 Mtpa CO<sub>2</sub>-capture scale. It offers:

- a high-purity CO<sub>2</sub> stream suitable for sequestration or utilisation projects;
- a highly adaptable, standalone system suitable for retrofitting and greenfield developments across a wide variety of industrial applications, gas flow rates and CO<sub>2</sub> concentrations;
- low operating costs; and
- continuous technological developments to reduce capture costs and energy requirements through extensive research and development, targeted piloting and demonstration campaigns.



## DESCRIPTION

### Process description

Figure 1 shows the CANSOLV CO<sub>2</sub> Capture System. The key steps are:

1. Feed gas is quenched and saturated in a circulated water pre-scrubber.
2. Gas contacts the lean amine solution in a counter-current mass transfer, packed absorption column.
3. CO<sub>2</sub> is absorbed and the treated gas exits to atmosphere.
4. Midway along the column, partially loaded amine is removed from the tower, cooled and reintroduced over a layer of mass-transfer packing.
5. CO<sub>2</sub>-rich amine from the absorption column is pumped through a lean–rich amine heat exchanger and then on to the regeneration column.
6. Rising, low-pressure saturated steam in the column regenerates the lean amine solution. CO<sub>2</sub> is recovered as a pure, water-saturated product.
7. Lean amine is pumped from the stripper reboiler to the absorption column for reuse in capturing CO<sub>2</sub>.
8. The CO<sub>2</sub> is directed to by-product management systems.
9. Energy is recovered through a system such as a mechanical vapour recompression compressor and/or a condensate flash, which helps to reduce the net reboiler duty requirements for amine regeneration.

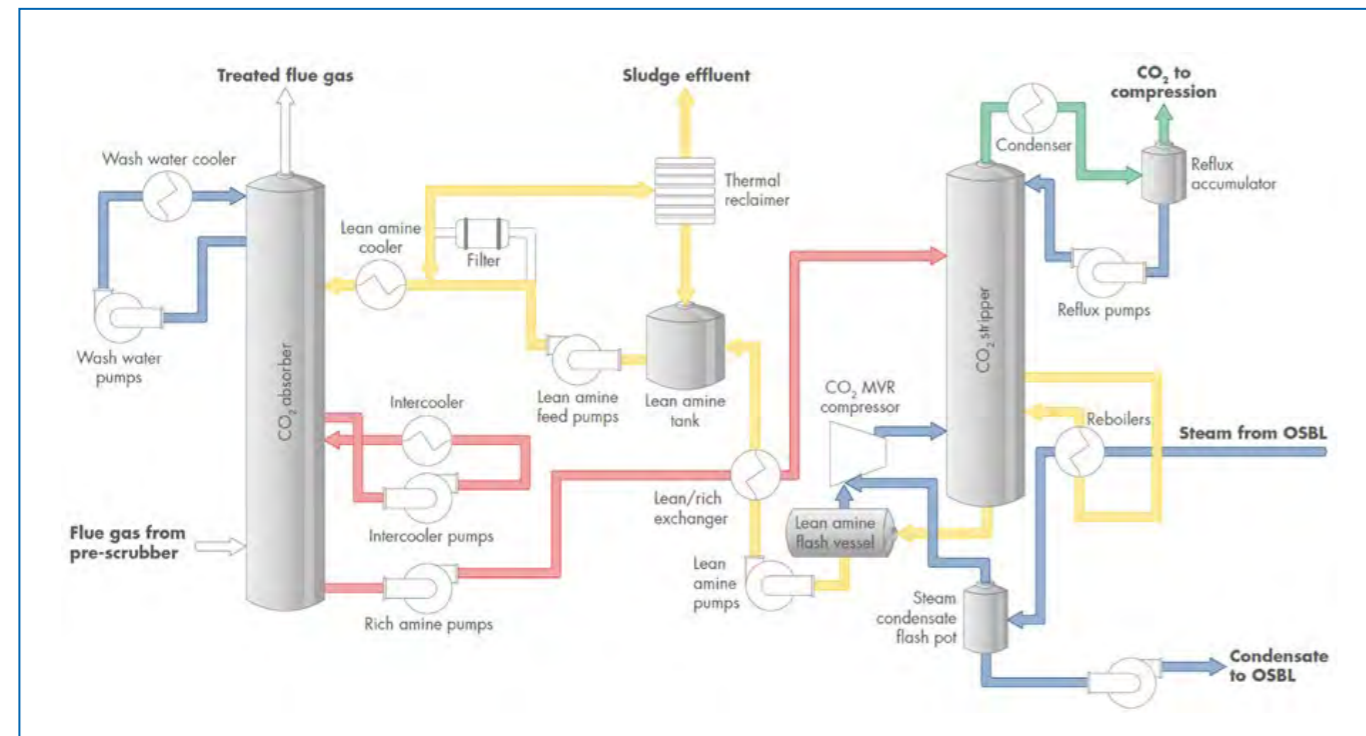

Figure 1. Shell CANSOLV™ CO<sub>2</sub> Capture System.

### Proof point: SaskPower 1 Mtpa CCS project

Because of tighter regulations, SaskPower needed to reduce CO<sub>2</sub> and SO<sub>2</sub> emissions at its Boundary Dam power station in Saskatchewan, Canada, which is a significant source of power for the region.

After carefully evaluating a range of technical options, SaskPower chose to add a CANSOLV™ SO<sub>2</sub>-CO<sub>2</sub> Integrated Capture System for combined carbon capture and flue-gas desulphurisation. It opted to do this for a 150-MW unit that was due for refurbishment. This involved adding a 55-m-tall CO<sub>2</sub> absorber, a 40-m-tall CO<sub>2</sub> stripper, a 31-m tall SO<sub>2</sub> absorber and a 17-m-tall SO<sub>2</sub> stripper.

In 2014, the power station became the first in the world to successfully use CCS at scale. The plant has been in operation now for over 7 years with the capacity to capture up to 1 Mtpa CO<sub>2</sub>, thereby helping SaskPower to meet strict Canadian regulations on CO<sub>2</sub> emissions from coal-fired power stations and thus retain its licence to operate. The CO<sub>2</sub> is compressed, transported through pipelines and permanently stored in deep geological formations as part of an enhanced-oil-recovery operation. The captured SO<sub>2</sub> is converted to 60 t/d of a marketable sulphuric acid that can be used as a feedstock for the local fertiliser industry.

The learnings from this still-operating, first-of-a-kind deployment continue to help develop Shell's CANSOLV™ CO<sub>2</sub> capture technology and promote and develop CCS projects globally.

### Proof point: Polaris CCS project

Shell's CANSOLV™ CO<sub>2</sub> Capture System has been selected for the proposed Polaris CCS project, one of a series of low-carbon opportunities being explored to decarbonise the Scotford complex, Alberta, Canada, to create one of Shell's proposed five global energy and chemicals parks. The initial phase is expected to start operations in about the middle of the current decade, subject to a final investment decision by Shell, which is expected in 2023. Polaris would have storage capacity of about 300 million tonnes of CO<sub>2</sub> over the life of the project. When fully built, Polaris would contribute to the region becoming a blue hydrogen hub.





## SUMMARY

Shell Catalysts & Technologies offers two leading, amine-based and high-capacity carbon-capture technologies, ADIP ULTRA™ and CANSOLV™ CO<sub>2</sub> Capture System, that are robust and proven, and have established records of performing cost-effectively in a wide range of industries.

Shell's ADIP ULTRA™ technology captures CO<sub>2</sub> from high-pressure, pre-combustion process streams, for example, from hydrogen manufacturing units, chemical plants and natural gas treating plants, while Shell's CANSOLV™ CO<sub>2</sub> Capture System captures up to 99% of the CO<sub>2</sub> from post-combustion (oxygen-containing) streams.

ADIP™ technology is deployed at more than 500 Shell and non-Shell sites worldwide and has established an enviable record for deep CO<sub>2</sub> removal in the natural gas sector. ADIP ULTRA™, the latest development, uses an optimised solvent formulation and an improved design based on years of operational learnings. With the latest-generation column internals (Shell Turbo Trays), this technology can maximise CO<sub>2</sub> capture and meet deep specifications for the treated gas while optimising solvent circulation and regeneration duty.

The ADIP Ultra™ technology offers the following distinct features, which makes it attractive for high pressure pre-combustion CO<sub>2</sub> capture:

- reduced capital cost through the latest-generation column internals (Shell Turbo Trays) in the absorber

- low regeneration energy requirements determined using a highly enhanced modelling capability based on many years of operating experience and data
- availability in advanced energy efficient line-ups that reduce capital and operating costs, depending on the treated gas specifications and application
- a solvent that is robust to foaming upsets and does not suffer from any degradation, which leads to zero waste from the process
- a noncorrosive, nontoxic solvent

Shell ADIP ULTRA™ technology combines with Shell gas partial oxidation technologies to provide the carbon capture step in the production of blue hydrogen from natural gas in a line-up known as The Shell Blue Hydrogen Process ([catalysts.shell.com/en/blue-hydrogen-on-demand-webinar](http://catalysts.shell.com/en/blue-hydrogen-on-demand-webinar)).

## BENEFITS

The Shell ADIP ULTRA™ pre-combustion gas-treating process cost-effectively treats gases containing high CO<sub>2</sub> levels. It is proven for CCS at a 1 Mtpa CO<sub>2</sub>-capture scale and, compared with conventional process line-ups, it can help to:

- reduce equipment costs by up to 30%
- cut regeneration energy requirements by up to 30%
- achieve deeper CO<sub>2</sub> removal



**DESCRIPTION**

**Process description**

ADIP™ technology dates to the 1950s. In 2000, ADIP-X technology was introduced. This featured a significantly upgraded solvent that unlocked a step change in CO<sub>2</sub> removal capability. The latest generation of this arrived in 2017 with ADIP ULTRA™, which has several enhanced design features, compared with previous-generation technology, that further reduced the cost of CO<sub>2</sub> removal. These includes a shorter absorber column, reduced solvent circulation, a slimmer regenerator and a smaller reboiler (Figure 1).

Combining ADIP ULTRA™ technology with Shell's new absorption column internals, Shell Turbo Trays, can further enhance process performance. At the column scale, liquid and gas flow counter-currently, that is, gas moves up while the liquid solvent moves down. However, on each tray within each element, gas and liquid flow co-currently within multiple contacting boxes before being separated effectively (Figure 2). Contact between the gas and the liquid is increased significantly, which enables higher mass transfer rates. The net effect is to increase the hydraulic limits of the system, which means operators can process higher CO<sub>2</sub> concentrations and increase capacity by up to 80% or reduce the column diameter by up to 35% and the weight by up to 50%.

ADIP ULTRA™ technology uses two amines, methyl diethanolamine (MDEA) as the main reactant and piperazine as the accelerator, and water. It can help to reduce the capital and operating costs of grassroots plants and revamps owing to the solvent's high capacity for CO<sub>2</sub> and its low circulation rate compared with aqueous MDEA. ADIP ULTRA™ solvent can facilitate efficient and stable operations owing to its characteristics of low levels of hydrocarbon solubility, foaming, fouling, corrosion and degradation.

The line-up can be varied, for example, using a hot flash instead of the regenerator, depending on the CO<sub>2</sub> removal requirements. This line-up is fully derisked and part of the Shell Blue Hydrogen Process.

**Proof point: Quest 1 Mtpa CCS project**

The Scotford upgrader in Alberta, Canada, generates CO<sub>2</sub> during hydrogen manufacture. As part of the Quest CCS project, Shell's ADIP ULTRA™ technology captures CO<sub>2</sub> from the three hydrogen manufacturing units' process gas streams. The captured CO<sub>2</sub> is then dehydrated and compressed before being transported about 75 km by pipeline and injected and permanently stored 2 km underground. The facility has a proven CO<sub>2</sub>-capture capacity of over 1 Mtpa CO<sub>2</sub> and has captured more than 6 million tonnes of CO<sub>2</sub> since coming online in 2015. The facility has better than projected reliability, cost and storage performance, and greater than 99% uptime. Its operating cost is approximately \$25/t of CO<sub>2</sub> and it would cost about 30% less if built today.

**Proof point: The Porthos CCS project**

In September 2021, a final investment decision was made to build an 0.82 Mtpa biofuels facility as part of the transformation of Pernis refinery, the Netherlands, into the Shell Energy and Chemicals Park Rotterdam, one of five global energy and chemical parks. Once built, the facility will be among the biggest in Europe to produce sustainable aviation fuel and renewable diesel made from waste. Carbon dioxide (CO<sub>2</sub>) emissions from the manufacturing process will be captured using Shell's ADIP ULTRA™ technology and stored in a depleted North Sea gas field as part of the Porthos CCS project. A final investment decision for Porthos CCS project is expected in 2022.

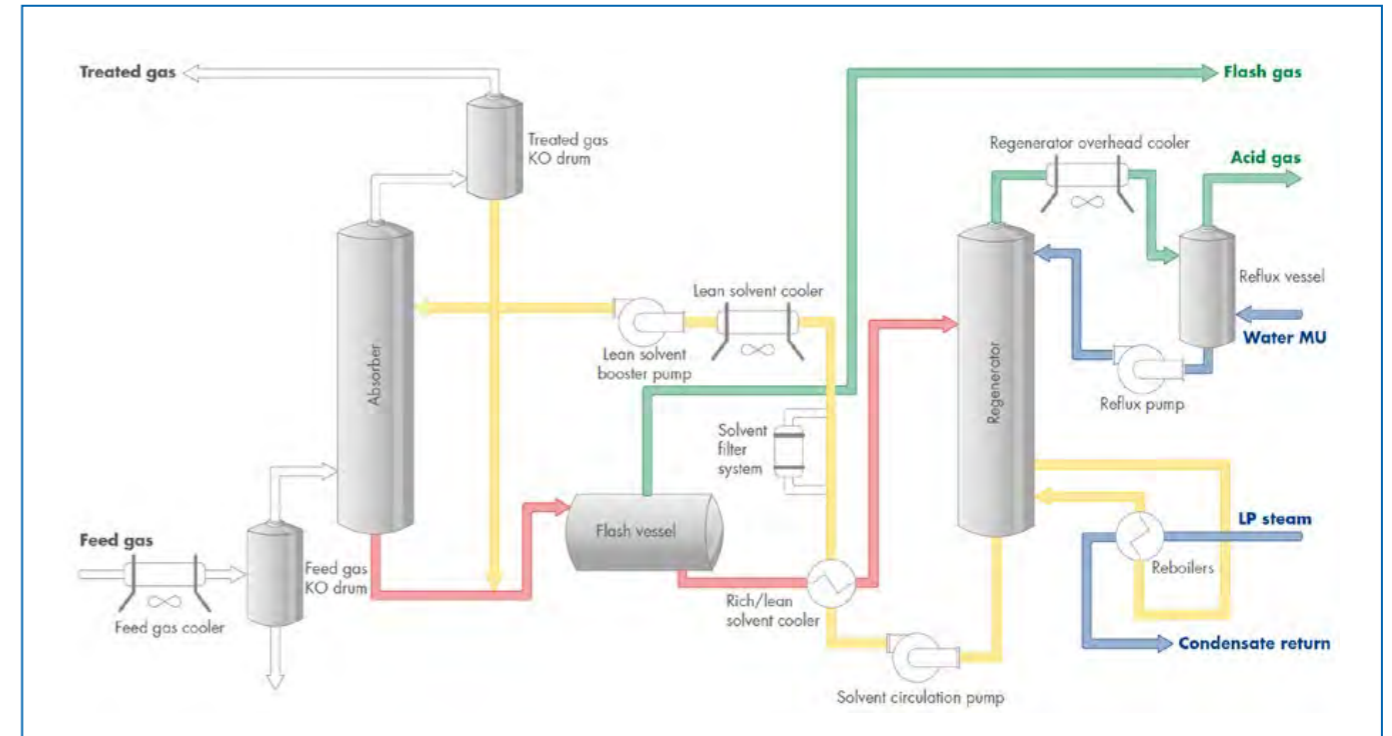

Figure 1. The Shell ADIP ULTRA™ process.

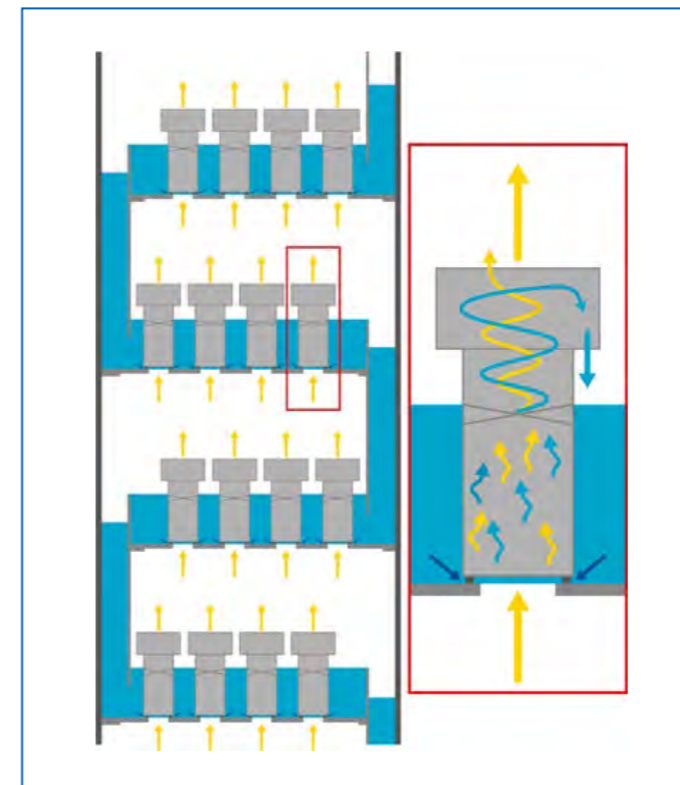

Figure 2. Increased capacity from Shell Turbo Trays.

\*ADIP and CANSOLV are Shell trademarks



## SOLID SORBENT TECHNOLOGY SHELL



### SUMMARY

The Solid Sorbent Technology (SST) is a novel technology that separates CO<sub>2</sub> from flue gas in a continuous Temperature Swing Adsorption (TSA) fluidized bed process using solid adsorbent. The technology is being developed for medium to small capture capacity across a range of sectors, with industrial partners. The technology potentially delivers simultaneously > 90% CO<sub>2</sub> capture efficiency and

> 95% CO<sub>2</sub> purity with low to no process-related emissions and with lower capture costs. The technology is currently piloted at BMC Moerdijk in a 1 tonne CO<sub>2</sub>/day pilot plant operating 24/7 to optimize the process and qualify new adsorbents. A technology readiness level (TRL) of 6 has been reached. The next steps are to de-risk the technology further to enable first deployment.

### BENEFITS

- Pilot plant results show that the new process can separate over 90% of the CO<sub>2</sub> from industrial gas and that this CO<sub>2</sub> has a purity of over 95% (dry basis), even at inflow CO<sub>2</sub> concentrations of less than 4 percent by volume.
- Solid sorbent technology development focusses on medium to small scale application (0.1-0.5 Mtpa CO<sub>2</sub>), including waste to energy, hydrogen manufacturing and specific applications in the steel and cement industries. End user experience is brought into the development via collaboration with external partners.
- Pilot Plant operation shows that without any flue gas post-treatment, the atmospheric emissions from this process are very low, significantly less than 1 milligram/normal cubic meter (mg/Nm<sup>3</sup>) of ammonia and below the detection limit (< 0.2 mg/Nm<sup>3</sup>) for other potential degradation products. The water condensate from the process contains mainly ammonia that can be removed in a relatively simple treatment plant to produce boiler feed water make-up.
- Work to date has shown that CapEx is competitive for this technology, with room to reduce further. OpEx reduction is targeted by developing a novel sorbent to reduce cost further whilst maintaining emissions benefits.

CONTACT

Chris Egby

Web: [www.shell.com/ct](http://www.shell.com/ct)

### DESCRIPTION

The solid sorbent technology is an innovative process, which separates carbon dioxide (CO<sub>2</sub>) from flue gas streams. This continuous temperature swing adsorption (TSA), fluidized bed process uses a solid adsorbent and is being developed for the delivery of high capture performance, lower capture costs and low emissions.

At low temperatures (ca. 50 °C), CO<sub>2</sub> is first adsorbed in a first multi-staged fluidized bed (adsorber) where heat is released due to the exothermicity of the adsorption reaction. Subsequently, the adsorbent is transported in a riser to a second multi staged fluidized bed (desorber) via heat exchangers, where the previously bound CO<sub>2</sub> is released using steam at a temperature of 120 °C. In this way, the adsorbent is regenerated (in a continuous process) and can be returned to the adsorber where it is again available for CO<sub>2</sub> capture.

A fluidizable adsorbent material is used where CO<sub>2</sub> can be very selectively bound to, for example, active amine groups that are tethered on the adsorbent surface. The adsorbent displays high temperature and mechanical stability and as a result, produces very low emissions without the need for

expensive post-treatment. The process contains no liquid water, and therefore, lower-cost construction materials can be used.

The base case material is a chemisorbent, fluidizable, attrition resistant and suitable to be produced at a tonne scale for commercial applications. Novel adsorbents are being developed with improved properties using less steam for the regeneration of the adsorbent and to extend the adsorbent lifetime.

In the ViennaGreenCO<sub>2</sub> project, the technical University of Vienna and Natural Resources and Applied Life Sciences (BOKU) designed and operated a pilot plant for 900h in a flue gas slip stream from a wood fired power plant at Wien Energie. After project closure, the pilot plant was moved to the Netherlands and since early 2021, operated 24/7 in a flue gas slip stream from the poultry litter fired power plant at BMC Moerdijk in the Netherlands. The pilot plant is used to qualify novel adsorbents, optimize the process consumables, and test equipment improvements. Next step undertaken is to scale-up and prepare the technology for commercial deployment.

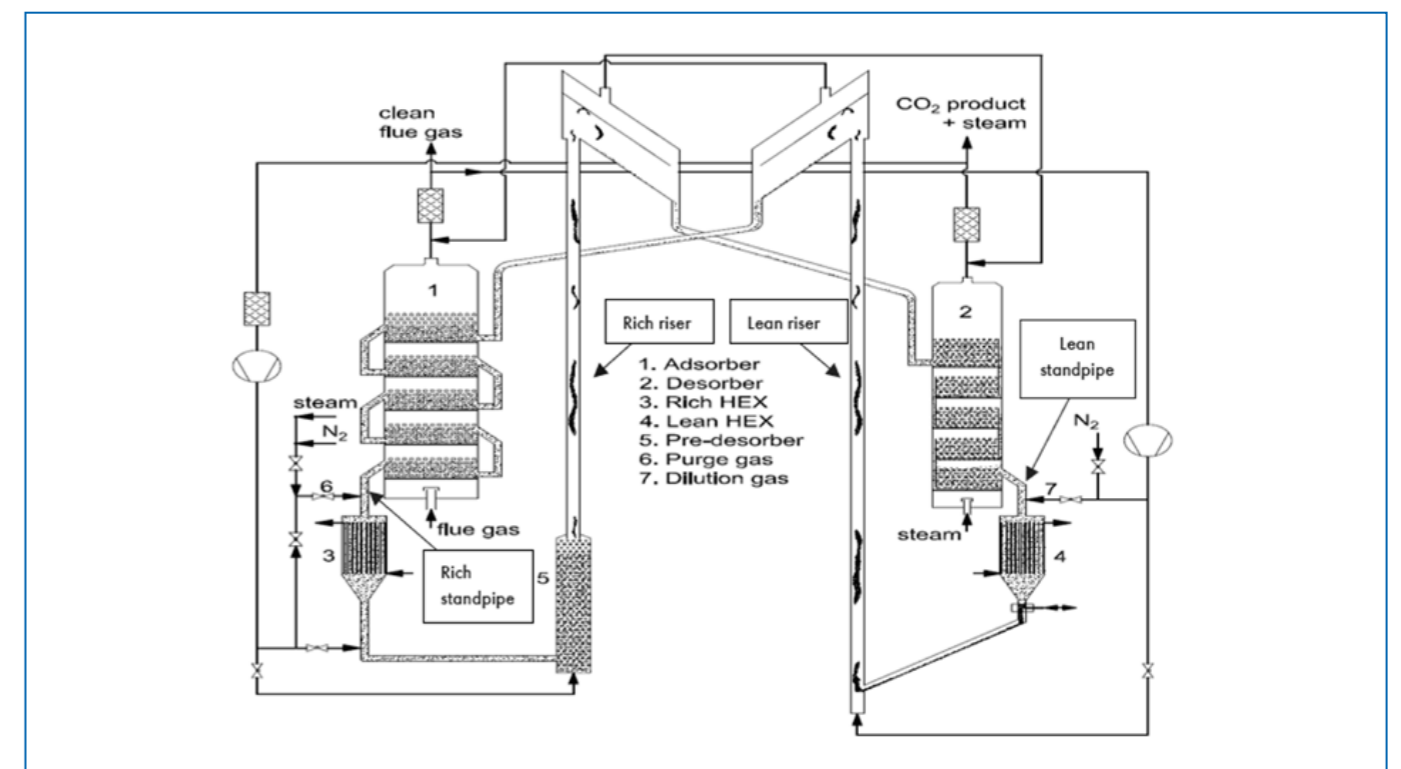

Figure 1: Simplified Process flow scheme of the Solid Sorbent Technology pilot plant.





**SUMMARY**

Capture of CO<sub>2</sub> from industrial operations using chemical solvents is technically proven, but the costs in terms of capital and energy use are high and the potential for toxic emissions has prompted developers to seek other technological approaches. One avenue showing promise is the use of solid adsorbents. Svante has developed a solution to capture large-scale CO<sub>2</sub> emissions, produced from hard-to-abate industries such as cement, hydrogen, chemicals, and pulp & paper, either for safe storage or to be used for further industrial use in a closed loop.

Svante's technology is currently being deployed in the field at pilot plant-scale by industry leaders in the energy and cement manufacturing sectors, such as:

- CO<sub>2</sub>MENT Pilot Plant Project: Partnership between Holcim and TotalEnergies operating a 1 tonne per day (TPD) plant in Richmond, British Columbia, Canada, that will re-inject captured CO<sub>2</sub> into concrete.
- Cenovus: Construction and commissioning of a 30 TPD demonstration plant completed in 2019 at an industrial facility in Lloydminster, Saskatchewan, Canada.
- Chevron USA: A 25 TPD demonstration plant is currently under construction for deployment near Bakersfield, California, USA.
- In addition, several engineering projects for commercial-scale carbon capture projects ranging from 500 to 4,500 TPD are underway in North America and Europe.

Svante has now attracted more than US\$195 million in funding since it was founded in 2007 and is currently expanding its commercial filter manufacturing facility in Canada. By the end of 2023, the new facility will have an annual capacity to deliver filter modules capable of removing 5 Mtpa CO<sub>2</sub>.

Svante's energy efficient and low-cost technology, the VeloxoTherm™ carbon capture process, is an intensified rapid-cycle Temperature Swing Adsorption (TSA) system using advanced Structured Adsorbent Beds (SAB). This novel process is designed to capture CO<sub>2</sub> directly from industrial sources and release pure CO<sub>2</sub> in less than 60 seconds, compared to hours for other technologies and requiring significantly less capital cost. The capture process is implemented via a device similar to that of regenerative air heaters widely used in power plants, in which a proprietary structured adsorbent is arranged on a circular rotating structure, known as a Rotary Adsorption Machine (RAM). The device simultaneously exposes different segments of the structure to each step of the TSA cycle. A key advancement is the development of innovative adsorbent materials, which enable the use of a rapid temperature swing cycle.

**BENEFITS**

- Svante's technology utilizes a single piece of compact equipment enabling a competitive reduction in capital costs compared to first generation approaches.
- Capacity is scalable in multiples of individual Rotating Adsorption Machines (RAMs) between 500 and 5000 TPD of CO<sub>2</sub> captured, depending on the application and product purity requirements.
- Svante's technology is flexible by using different adsorbents and can target low and high concentration industrial flue gases.
- Inherent ability to load follow and start and stop extremely quickly by easily controlling the rotation speed of the RAM. This feature enables CO<sub>2</sub> capture from intermittent process such as lime production PFR kilns and electric arc furnaces.
- Svante's proprietary VeloxoTherm™ process is environment-friendly based on novel Structured Adsorbent Beds (SAB), which are not subject to nitrosamine and nitramine emissions.
- No process safety associated with new hazardous chemicals being brought onsite.

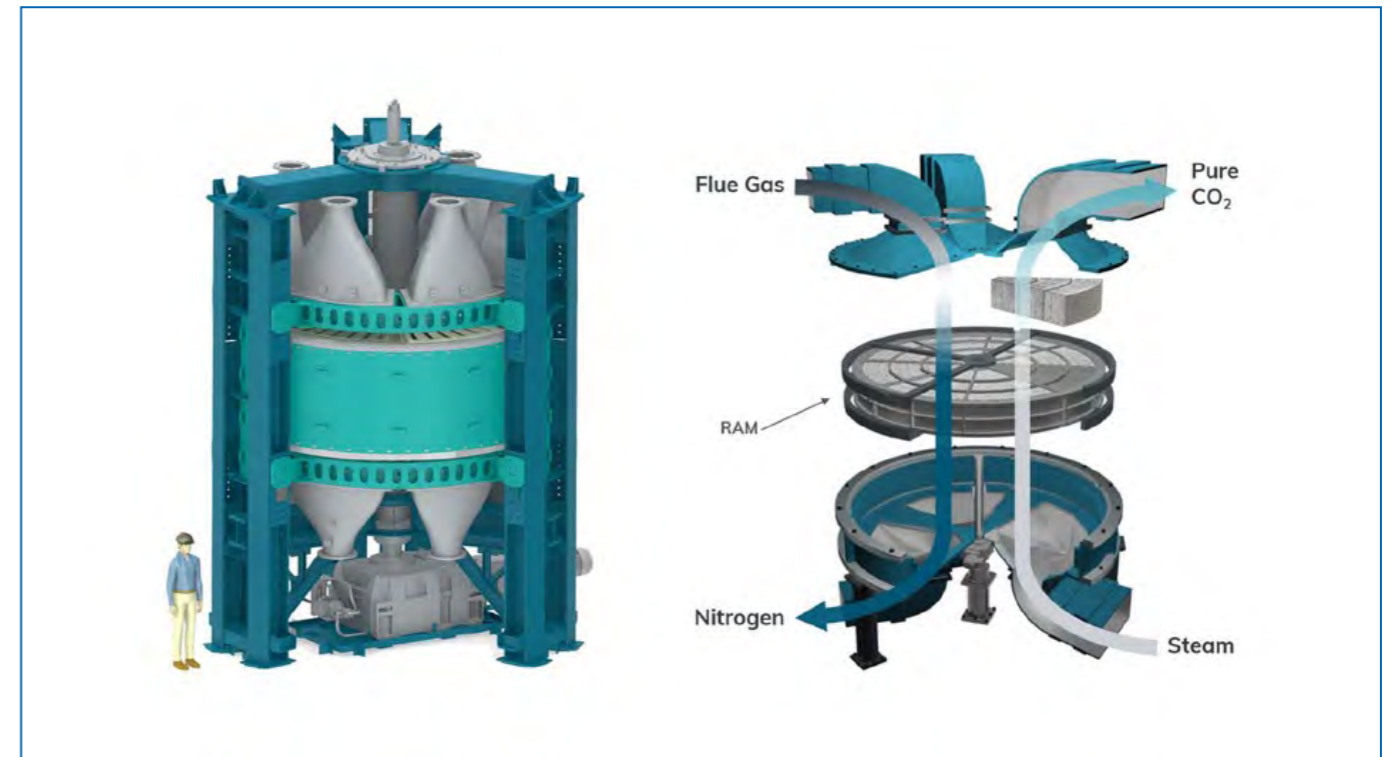



## CO<sub>2</sub> Capture Plant Process Description

The Svante carbon capture process consists of a series of steps which include passing flue gas, regenerating steam, and conditioning air through structured adsorbent beds in a specific order.

- i. Adsorption: The first step in the process is the introduction of the feed gas into the structured adsorbent beds, where CO<sub>2</sub> is adsorbed onto the surface of the adsorbent, while the remainder of the flue gas mainly N<sub>2</sub>, O<sub>2</sub> and H<sub>2</sub>O is sent to the stack as spent/exhaust gas.
- ii. Regeneration: The CO<sub>2</sub>-rich adsorbent bed then rotates to a sector of the process where low pressure steam flows through it, requiring only a small amount of superheat to overcome heat losses from the system. This is the first regeneration step, where steam regenerates the adsorbent, releasing a stream composed primarily of CO<sub>2</sub> and steam.

- iii. Conditioning: After regeneration with steam, the bed rotates through a sector of the process where heated ambient air is used to condition and cool the structured adsorbent. The ambient air stream, termed Conditioning Gas, removes most of the water vapor from the adsorbent.

The adsorption, regeneration, and conditioning functions described above are integrated and implemented in the RAM, as shown in the figure below.

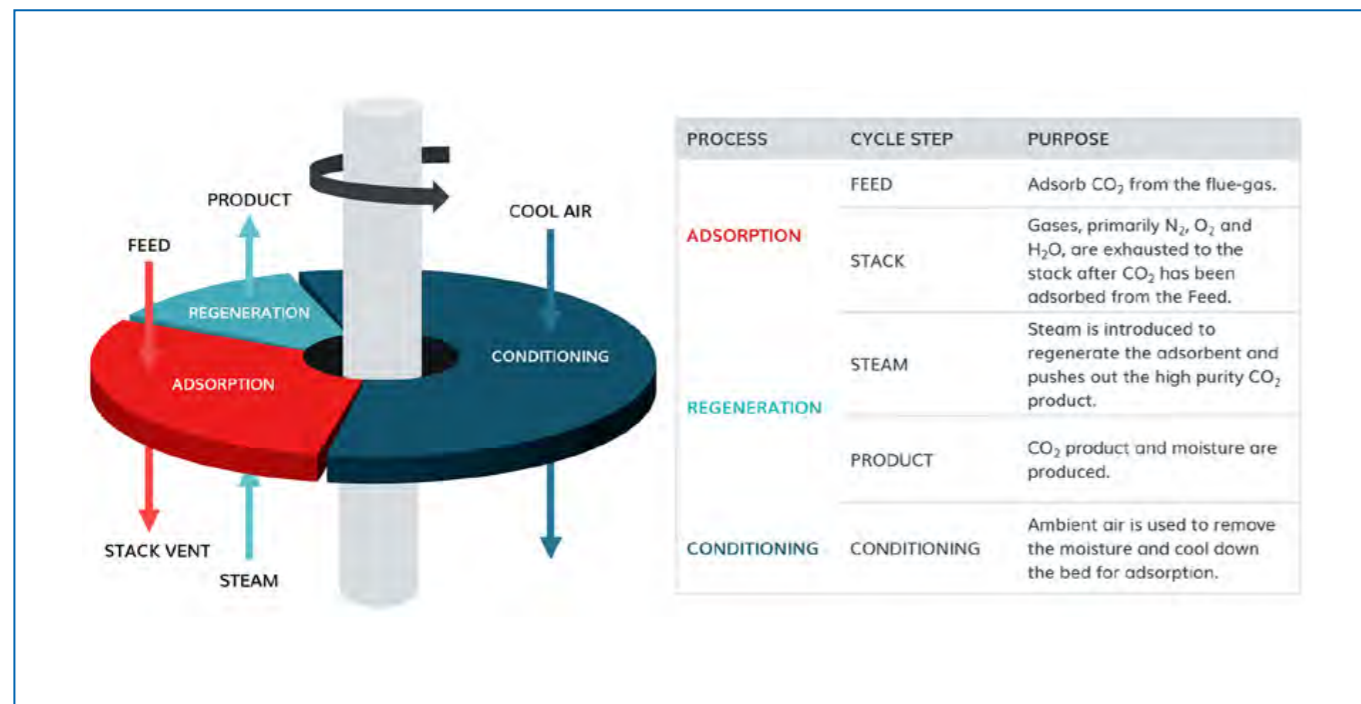



# TRANSPORT







## SUMMARY

Kawasaki Kisen Kaisha, Ltd. (“K” LINE), founded in 1919, is one of the largest shipping companies in the world. Its core business is marine transportation particularly deploying LNG tankers, LPG tankers, crude oil tankers, offshore support vessels, dry bulk carriers, car carrier, and containership. “K” LINE is operating about 440 vessels worldwide as of today.

We will put full effort into the decarbonization of the company and society with the aim of achieving a

sustainable society and enhancing the corporate value. The initiatives include vessels for projects related to offshore wind power, transportation of new energy sources such as hydrogen and ammonia, and transportation of CO<sub>2</sub> captured from CCUS projects. We continue to leverage the knowledge and network that we have accumulated over the years to promote the initiatives. We believe that supporting and promoting decarbonization of society is a major opportunity to open up new domains for the shipping business.

## BENEFITS

- “K” LINE currently operates 47 LNG carriers and 4 LPG carriers and has extensive experience and know-how in the liquefied gas transportation. Based on our experience, we can provide safe and reliable transportation service of liquefied CO<sub>2</sub> (LCO<sub>2</sub>).
- Carbon dioxide (CO<sub>2</sub>) must be constantly under pressure to remain in liquid phase and LCO<sub>2</sub> needs to be carried in pressurized tanks for shipping. “K” LINE has accumulated operational experience of pressurized tanks and can meet customers’ transportation requirements under various pressure conditions.
- “K” LINE is participating in the demonstration project on LCO<sub>2</sub> ship transportation and developing LCO<sub>2</sub> transportation technology under low-temperature and low-pressure conditions, which is considered to be suitable for large-scale LCO<sub>2</sub> transportation. We contribute to the development of the CCUS value chain in terms of ship transportation.
- “K” LINE is steadily promoting an action plan of achieving net-zero greenhouse gas (GHG) emissions by 2050 and working on various approaches such as improvement in efficiency, zero-emission marine fuel and on-board CCS system. We are also proceeding with another demonstration project of, “CC-Ocean”, which is on-board CO<sub>2</sub> capture plant. We can contribute to the zero emission of the entire CCUS value chain with such solutions.

## DESCRIPTION

“K” LINE considers the realization of a carbon-neutral society to be an important issue for society and is promoting various environmental initiatives.

In particular, “K” LINE has been promoting its CCUS and LCO<sub>2</sub> transportation businesses as key technologies to contribute to the zero emission of both our company and society.

“K” LINE has gained a lot of experience in the business of low-temperature liquefied cargo transportation such as LNG, LPG, hydrogen and ammonia transportation for a long time. In recent years, we have also been operating LNG bunkering vessels equipped with pressurized tanks, and have accumulated know-how on pressurized tanks, which are expected to be used for LCO<sub>2</sub> transportation. With this knowledge and a proven track record of safe operations, “K” LINE is now accelerating its CCUS-related business and is preparing for the future large-scale international LCO<sub>2</sub> transportation.

“K” LINE is currently developing CCUS technology from two angles.

Firstly, since 2021, “K” LINE is participating in the demonstration project on LCO<sub>2</sub> transportation supported by New Energy and Industrial Technology Development Organization (NEDO), Japanese national research and development agency. In this project,

the demonstration test ship will be constructed and dedicated to LCO<sub>2</sub> transportation. The project aims to develop the necessary technologies for an integrated LCO<sub>2</sub> ship transportation system and safe operational method. In this demonstration project, in addition to the existing technology of transporting LCO<sub>2</sub> under medium-temperature and medium-pressure conditions, a series of transportation experiments under various conditions, including low-temperature and low-pressure conditions will be conducted to develop a large-scale CCUS chain. “K” Line is in charge of safety evaluation and establishing technical guideline for LCO<sub>2</sub> transportation and cargo handling of the demonstration vessel. Then, “K” Line is also working on another demonstration project, called the “CC-Ocean”, which aims at onboard CO<sub>2</sub> capture to ensure zero emissions from vessels. We have been conducting a joint project with Mitsubishi Shipbuilding and Nippon Kaiji Kyokai (Class NK) to develop CO<sub>2</sub> capture plant onboard vessel as part of the “Research and Development for Advancing Marine Resources Technologies”. The plant was installed on the coal carrier “CORONA UTILITY” in early August 2021 to separate and capture CO<sub>2</sub> from the exhaust gas of the vessel’s engine. An operational test has been conducted in this regard. We, at “K” LINE, will further strengthen our efforts in the CCUS business and contribute to the realization of a net-zero society.







**SUMMARY**

Knutsen NYK Carbon Carriers AS (“KNCC”) is a joint venture owned by the Knutsen Group (Knutsen) of Norway and the NYK Group of Japan. Our owners already have a successful cooperation in place through Knutsen NYK Offshore Tankers, which is engaged in the shuttle tankers business.

KNCC’s PCO<sub>2</sub><sup>®</sup> technology is based on the preparatory compressed gas (PNG<sup>®</sup>) technology developed by Knutsen. The conceptual design started about 20 years ago with an idea to apply basic design principles from the pipeline offshore industry into a design of a CNG carrier, such as for the transportation of LNG in gaseous phase at 250 bar pressure. The technology has been further developed to transport liquids with high evaporation pressure such as crude oil, products and CO<sub>2</sub> at ambient temperatures.

Adoption of the above technology was made to enhance the process to design a containment system that would fulfil all safety requirements and proven viable at an efficient cost.

To meet our objectives, it was recognized at an early stage that strong partners had to be present to enable addressing all elements involved in the new concept. DNV accepted to perform all work necessary to qualify and demonstrate that the system was safe, reliable and technically viable. The other strategic partner, who accepted our approach,

was Europipe GmbH, Germany, who has participated throughout the entire Cargo Tank Cylinder (“CTC”) design and development program.

The strategic cooperation made it possible to achieve a DNV GASA (General Approval for Ship application) in CNG technology, ensuring that all requirements for a safe, reliable and robust solution for CNG marine transportation at 250 bar are met.

The PCO<sub>2</sub><sup>®</sup> technology is logic continuation of a feasibility study executed on behalf of a well-known Oil Major back in 2018. That study evaluated the feasibility to transport crude oil at high TVP (true vapor pressure). The latter including LPG in the crude flow. The study was based on the same cargo tank containment system. It became evident that the same system could be used for several products including CO<sub>2</sub>.

Following the above, the PCO<sub>2</sub><sup>®</sup> technology comprises the transport of CO<sub>2</sub> at ambient temperature in vertical stacked cylinders in the vessel’s cargo hold. The ambient temperature lies within the range of 0 - 10 °C and the pressure in the cylinders ranges from 34 bar to 44 bar. We are convinced that PCO<sub>2</sub><sup>®</sup> is the optimal transport condition and for direct injection offshore, where pipeline and shore storage for low and medium pressure is not feasible.

Below is an enthalpy diagram showing the transport condition of the CO<sub>2</sub>:

The PCO<sub>2</sub><sup>®</sup> vessel design, construction, fabrication and operation shall be based on Maritime Rules and Regulations and recognized Codes & Standards such as, but not limited to:

- IMO regimes
- IACS Classification Rules and Standards for design and Construction of Ships
- Flag state

Subject to direct injection offshore, the PCO<sub>2</sub><sup>®</sup> vessel will be equipped with an adequate DP system and a Submerged

Turret Loading (“STL”) compartment to accommodate a turret and swivel system for hook-up to a pre-installed STL loading buoy. In addition, KNCC will apply inherent competence and experience from KNOT for CO<sub>2</sub> offshore loading, offloading and injections by the PCO<sub>2</sub><sup>®</sup> vessels.

The PCO<sub>2</sub> vessel will have a certain number of cargo cylinders installed in the vessel’s cargo hold.

Number and size (height) will vary according to needs and requirements. Each cargo hold will have individual pumps and utility equipment for safe discharge and cargo monitoring.

Approval in Principle (AiP) has been awarded for PCO<sub>2</sub><sup>®</sup> tank system from DNV.

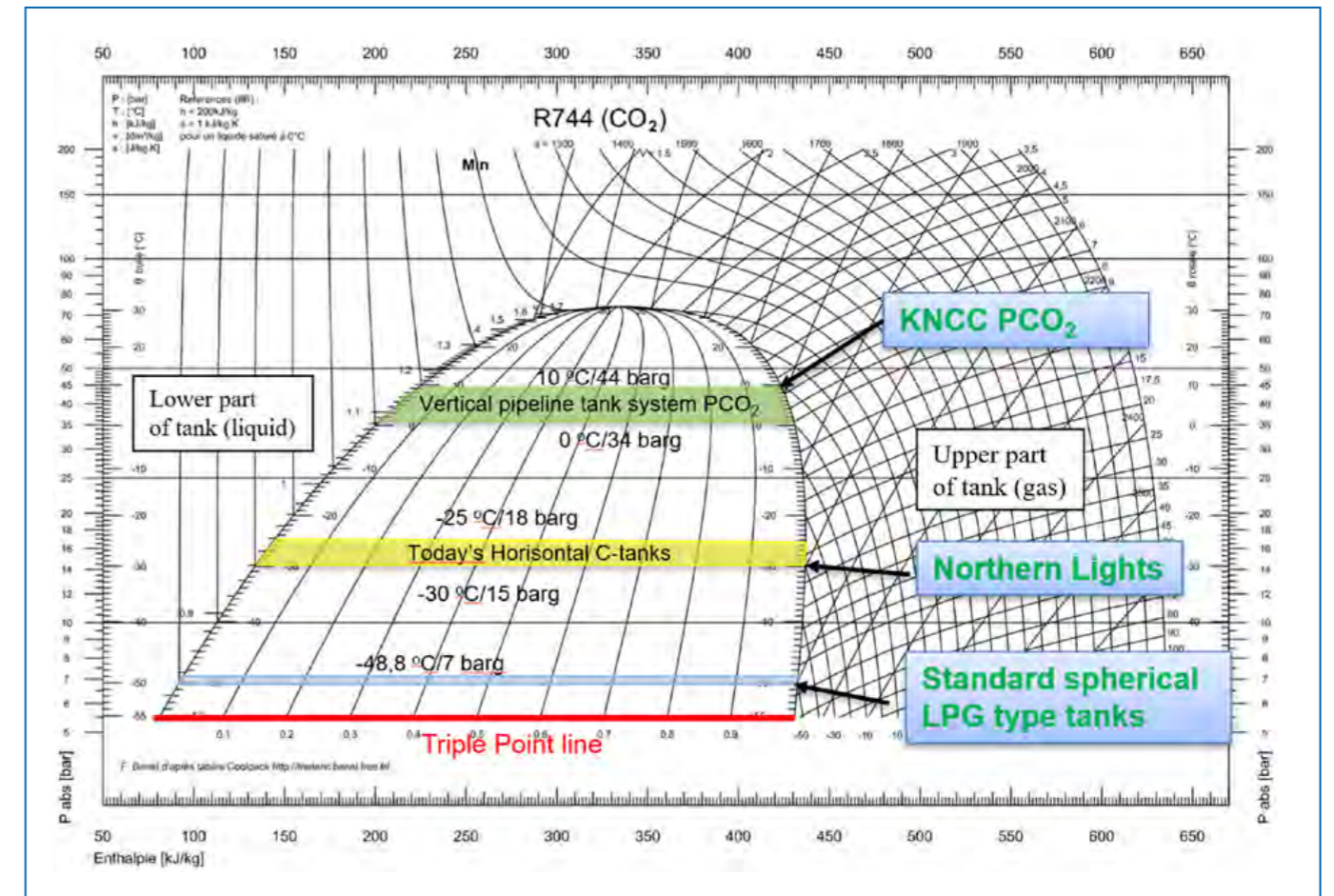





Image of a PCO<sub>2</sub>® vessel with bow-loading system.



Below – side view of the PCO<sub>2</sub>®



## BENEFITS

- Easily scalable for both the vessel size and the CO<sub>2</sub> volume to be transported
- Free surface tank effect eliminated regarding stability impacts
- Stable cargo condition during loading/offloading/transportation (far from triple point)
- Relatively lighter Cargo Containment System than other transportation modes, which require less ballast and draft (7-9m) making the vessel more compatible to many ports worldwide
- Lower cost for manufacturing Cargo Tank Cylinders by using well-known carbon steel
- Less facility (equipment)/energy/cost required for liquefaction and temporary storage at emission source
- Less facility (equipment)/energy/cost for heating and pumping required at injection/storage site
- Approval in Principle(AiP) awarded for PCO<sub>2</sub>® tank system from DNV.

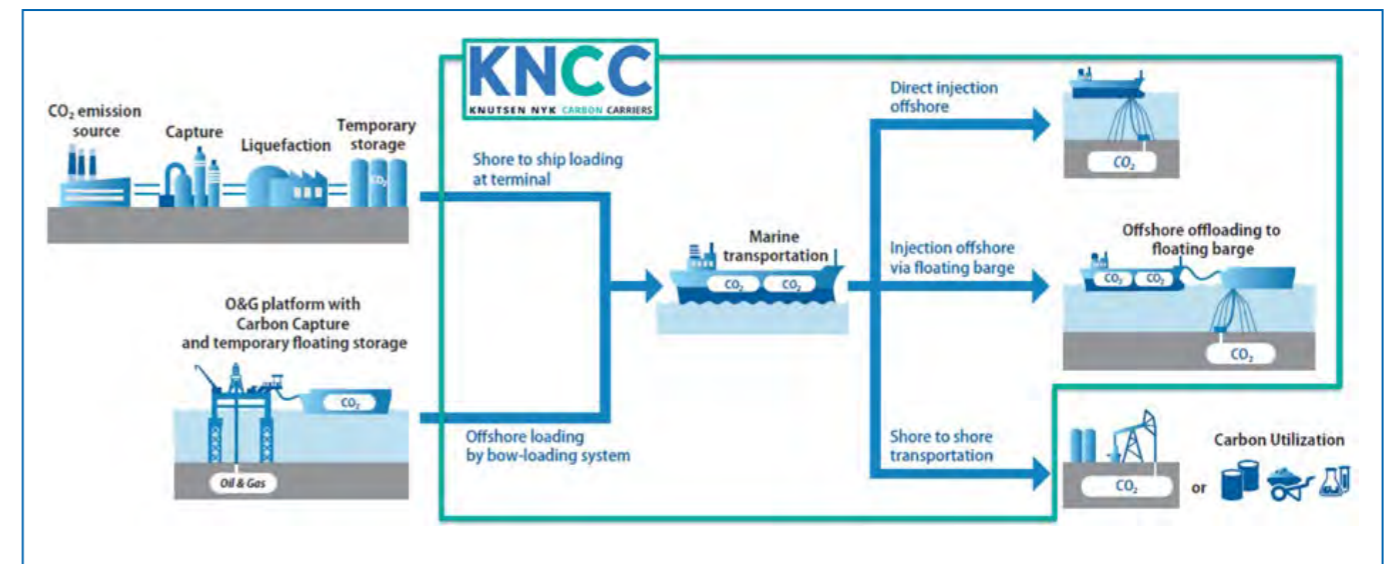
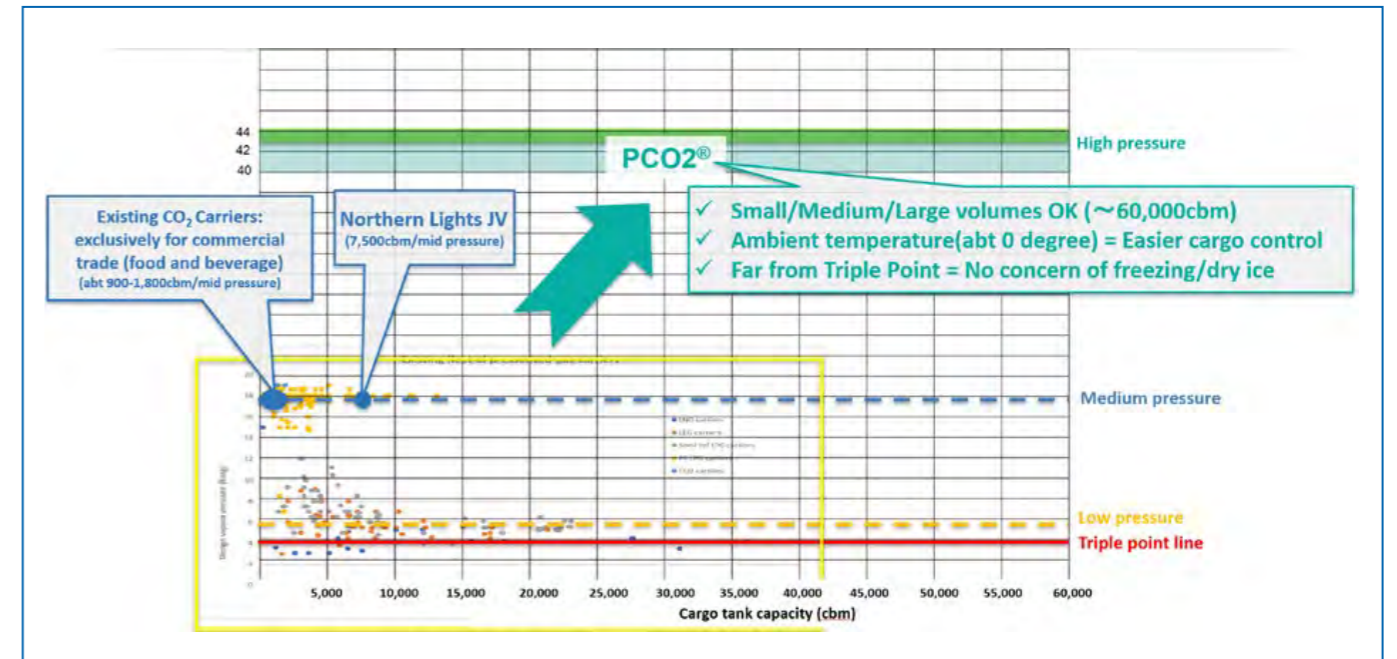





## SUMMARY

Currently approximately 80% of the captured industrial CO<sub>2</sub> emissions are purified by chemical absorption in post combustion applications at low pressure. Economic pipeline transportation and a safe sequestration require a high-density CO<sub>2</sub> (supercritical/dense condition) by compressing the stream beyond the critical point to pressures between 10 – 15 MPa.

Capturing, compressing, and transporting the CO<sub>2</sub> to a suitable sequestration site account for approximately 90% of the costs for each ton of CO<sub>2</sub>. Therefore, compressor efficiency improvement, waste heat use and power recovery are key for reducing costs.

Supercritical compression of wet CO<sub>2</sub>, integration of efficient cooling, drying and performance control concepts make CO<sub>2</sub> compression a challenge. MAN Energy Solutions SE has researched and developed these subjects for over three decades while monitoring more than 30 operating references including approximately 20 in the high-pressure, supercritical conditions. Our extensive experience, paired with a dedicated CO<sub>2</sub> test rig, in-house gearbox manufacturing and digital capabilities enable MAN Energy Solutions to optimize the compression solutions in terms of efficiency, heat and power recovery while securing a high-quality standard.

## BENEFITS

MAN Energy Solutions' compression and energy recovery solution are reliable, safe and efficient:

- Over 30 years of experience in CO<sub>2</sub> compression with integrally geared compressors.
- Own gearbox design and manufacturing
- Extensive knowledge in supercritical compression (up to 250 bara) based on research and modelling competencies
- Solutions provider for cost reductions in the CCS value chain integrating heat and power recovery within the compression system.
- Deep know-how in auxiliaries' integration, such as cooling and drying systems.
- Strong digital capabilities, e.g. digital twin, dynamic simulations, training simulator, remote services, efficiency optimization and preventive maintenance.

## DESCRIPTION

Our integrally geared compressor design is tailored for carbon dioxide compression up to 250 bara. Adapting the pinion speed compensates for the decreasing volume flow (high compressibility of CO<sub>2</sub>), thus maintaining the best efficiency throughout the entire compression.

Intercooling of the wet CO<sub>2</sub> after each compression stage and removal of the condensate reduces the water vapor content in the stream and the head requirements, thereby lowering the power consumption. Furthermore, hot water, oil, or even steam can be recovered from the intercoolers to supply heat for the CO<sub>2</sub> capture and purification process. For example, the heat recovered from the intercoolers can cover 30 - 50% of the energy required by the chemical absorption process for the desorption of captured carbon dioxide.

Admissions and extractions between stages make our integrally geared design extremely flexible for gathering or delivering multiple streams at different pressure levels, or even combining from different processes with the same compressor. MAN Energy Solutions can match our compressor to your process, thereby improving the overall efficiency. We co-operate with our customers and partners to find the best solution.



Our test benches can run ASME PTC10 Type 1 and 2 tests to prove performance and mechanical soundness.

MAN Energy Solutions has a unique CO<sub>2</sub> test bench that allows R&D tests in the supercritical phase, monitor seal behaviour and cooler heat transfer at high pressures, verify Joule-Thompson-Effects in valves, measure shaft vibrations, and bearing temperatures under severe conditions.

Predictability of the compressor plant behaviour, especially in emergency and transient situations are important to reduce risks and costs. Our digital competencies complement our portfolio with dynamic performance and training simulations of a digital twin. Remote services and commissioning, efficiency optimization and online monitoring reduce your costs and enhance the availability of your equipment.

Appropriate integration experience of different cooling systems, e.g. water cooled or air cooled heat exchangers, closed loop water systems and drying units such as triethylene glycol gas dehydration, molecular sieves and others contribute to the optimization of the plant.





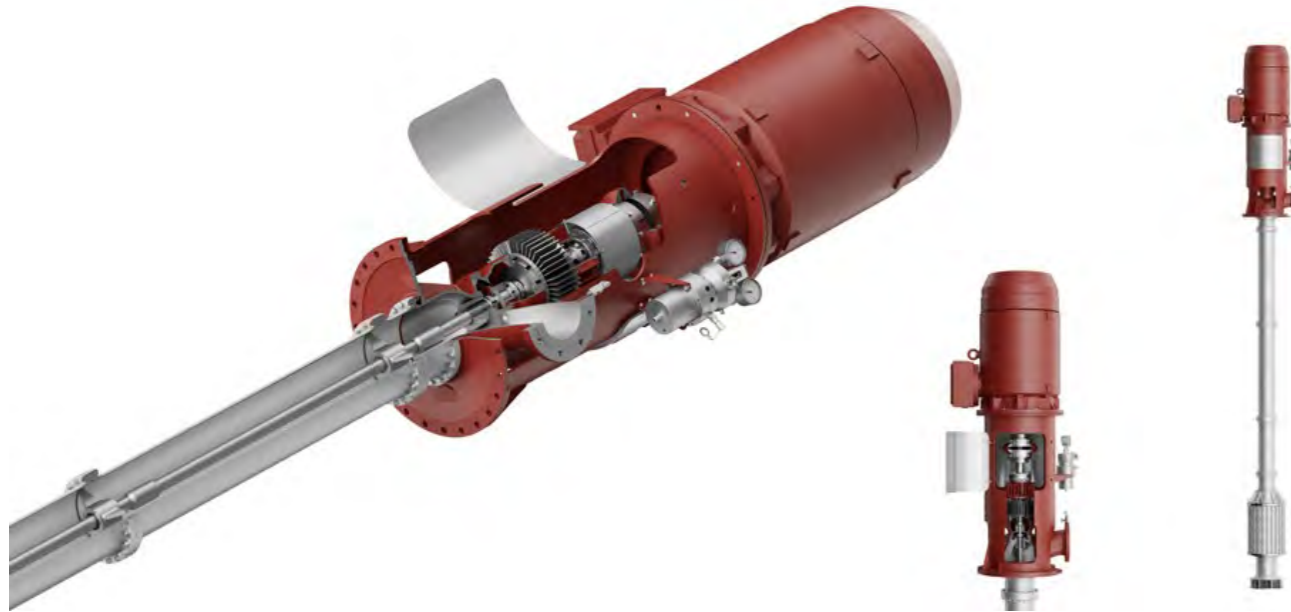

### SUMMARY

Svanehoj is a market leading pump manufacturer, specialised in multi-gas fuel and cargo pumping systems. Based upon nearly 100 years of experience of pumping liquids, we have developed an unparalleled design and technology, ensuring our customers the best, safest and most reliable pump solutions on the market.

Our pumping solutions are a key part of the fuel and energy cargo supply in the shipping industry, and we are committed to reducing the impact on the environment through sustainable solutions.

At Svanehoj, we believe in working closely with our customers, and we strive to build longstanding relationships. Our employees are highly educated, experienced, and possess the technical know-how required to suit the needs and demands of our customers. With our in-depth experience and a proven track-record, we make it simple to adapt to the fast-growing world of carbon-neutral solutions.

### BENEFITS

- Multi-gas: A Svanehoj pump can handle all types of gas cargo at all temperatures and gravities without any component changes; including CO<sub>2</sub>, LNG, LPG, ammonia, methanol, hydrogen, ethane, and ethylene.
- Service not required until 5 years of operation. Full overhaul after 10 years of operation,
- Low pressurized CO<sub>2</sub> with pressure down to 5.2 bar, which together with the unique design of the Svanehoj DW Pump ensures a low net positive suction head required (NPSHr) and reduces the risk of cavitation and dry ice formation.
- Fully pressurised tankers, cargo at ambient temperature, tank pressure more than 20 bar.
- Semi-refrigerated tankers, cargo liquified by cooling/pressure process down to -55 °C.

### DESCRIPTION

**Complex CCS solutions – we already have the experience**

Carbon Capture and Storage is described by many as one of the most promising technologies to help reduce CO<sub>2</sub> emissions from heavy transport and industry. In this context LCO<sub>2</sub> carriers will play an essential role in transporting liquefied CO<sub>2</sub> to depleted oil and gas reservoirs or other deep places, where it is stored.

What few people know is that, Svanehoj is one of the very few pump manufacturers with actual experience in CO<sub>2</sub> pumping systems. Already more than 20 years ago, we delivered our first deep-well cargo pump solution for an LCO<sub>2</sub> carrier, and our deep-well pump technology is suitable to support a growing CCS industry. So, even though long-term storage of CO<sub>2</sub> is currently in a rudimentary stage, we at Svanehoj already have the experience and competencies to supply the pumping systems.

The first Svanehoj deep-well cargo pump was developed in the 1960's. Since then, we have developed and manufactured tailored cargo pump solutions for more than 1,300 gas carriers, delivering more than 14,500 deep-well pumps around the world.

Our product range in deep-well gas pumps ensures suitability for almost all needs with tailored gas pump solutions for all vessel types. Our pumps can handle all types of gas cargo at all temperatures and gravities

without any component changes, including CO<sub>2</sub>, LNG, LPG, ammonia, methanol, hydrogen, ethane, and ethylene.

The Svanehoj deep-well pump is designed with the most sensitive components placed outside the tank, allowing easy access to bearings and mechanical seal with no need to depressurize the tank. The unique design of the deep-well pump eliminates excess heat and pressure and ensures a low NPSHr, which reduces the risk of cavitation and dry ice formation. In order to always ensure safe operation, the pump is equipped with a pressure booster that monitors the pressurized shaft seal and ensures an overpressure in the mechanical seal of 2 bar compared to the actual tank pressure.

With a Svanehoj deep-well pump, maintenance is easy. As all sensitive components are placed outside the tank, the pump only requires servicing every five years during regular docking. In fact, the maintenance until 10 years/50,000 hours does not require access to the tank.

At Svanehoj, we take pride in being flexible and adapting solutions to specifically suit any challenges that a shipowner or a shipyard may encounter. Our dedicated project team tailors gas pump solutions for all vessel types, from the smallest fully pressurized push barges and dedicated CO<sub>2</sub> carriers to the largest fully refrigerated very large gas carriers (VLGCs).







**SUMMARY**

**Innovative Products for Decarbonizing the Industry**

The demand for energy continues to increase around the globe with particularly high growth rates and rapid economic expansion worldwide. As a result, the world is now facing the challenge of reducing CO<sub>2</sub> footprint and achieving Net-Zero Emissions by 2050.

Torishima is well-placed to provide a full range of pumps designed for the applications needed within the carbon-intensive industry from carbon capture plants to CO<sub>2</sub> transport and storage. The products are applicable to fuel variants of blue or green hydrogen for small combined-cycle to large super-critical thermal stations. We are able to supply pumps for flue gas treatment, carbon capture, boiler feed pumps, boiler circulation pumps, circulating water pumps and condensate extraction pumps as well as a range of auxiliary duties. Torishima pumps have been installed globally in this market.

**Research & Development**

Energy demand continues to increase globally, however considering the need to also conserve power, Torishima's objective is to produce high efficiency pumping equipment. Torishima continues to invest in research and development (R&D) to meet such objectives, developing highly technical equipment with high reliability whilst keeping our environmental commitments.

**Service Solutions**

Torishima has a large installation base with pumps located throughout the world. We are conscious that we must provide a reliable service support network to our clients. To this end, we have a network of service facilities located in key areas providing access to both spare parts and innovative service solutions.

Through subsidiary, C.P.R Ltd, Torishima has over 30 years' experience in the inspection, maintenance, installation and commissioning of submersed motors and cryogenic pumps for the liquefied gas industry. This experience is fully transferable to carbon capture, utilisation and storage (CCUS) and greenhouse gas (GHG) reduction pumping equipment.

**One Stop Shop/Cradle to Grave**

Key benefits that Torishima brings to the CCUS, and carbon-intensive market include:

- As a market leader in desalination, Torishima has extensive pumping experience in the field of water management, which will be crucial to the carbon footprint of the carbon capture plants
- In conjunction with our partners, we can supply or develop pumps for all of the applications in the CCUS process
- With our worldwide service network and specialised expertise in cryogenic pump repair, we can offer a cradle to grave service on the pumping equipment



Figure 1 Water Transmission Pump



Figure 2 Cooling Water Pump



Figure 3 SPV Water Intake Pump (Left) & MHB Barrel Case Pump (Right)



# CENTRIFUGAL PUMPS FOR DECARBONIZING TORISHIMA

CONTACT

Bjarne Olsen  
Email: [bjarneolsen@torishima.co.uk](mailto:bjarneolsen@torishima.co.uk)  
Web: [www.torishima.co.jp/en](http://www.torishima.co.jp/en)

## Carbon Capture and Storage

Torishima Pump has a wide product range of centrifugal pumps capable of providing optimum pump performance for a carbon capture and storage plant. Reference can be made to a waste-to-energy plant fitted with an end of pipe carbon capture plant.

Torishima and Partners' Products for Various CCUS needs:

The product range of Torishima Pump combines our capabilities within the power generation and desalination industry to provide optimum pump solutions for various capture technology processes, such as post combustion, pre-combustion and oxy fuel combustion capture. Both low-pressure and high-pressure pumps for application as water intake and cooling systems, solvent handling, steam power regeneration and CO<sub>2</sub> treatment and storage can be provided. In addition, Torishima is also targeting the fuel switch market by providing liquid hydrogen pumps.

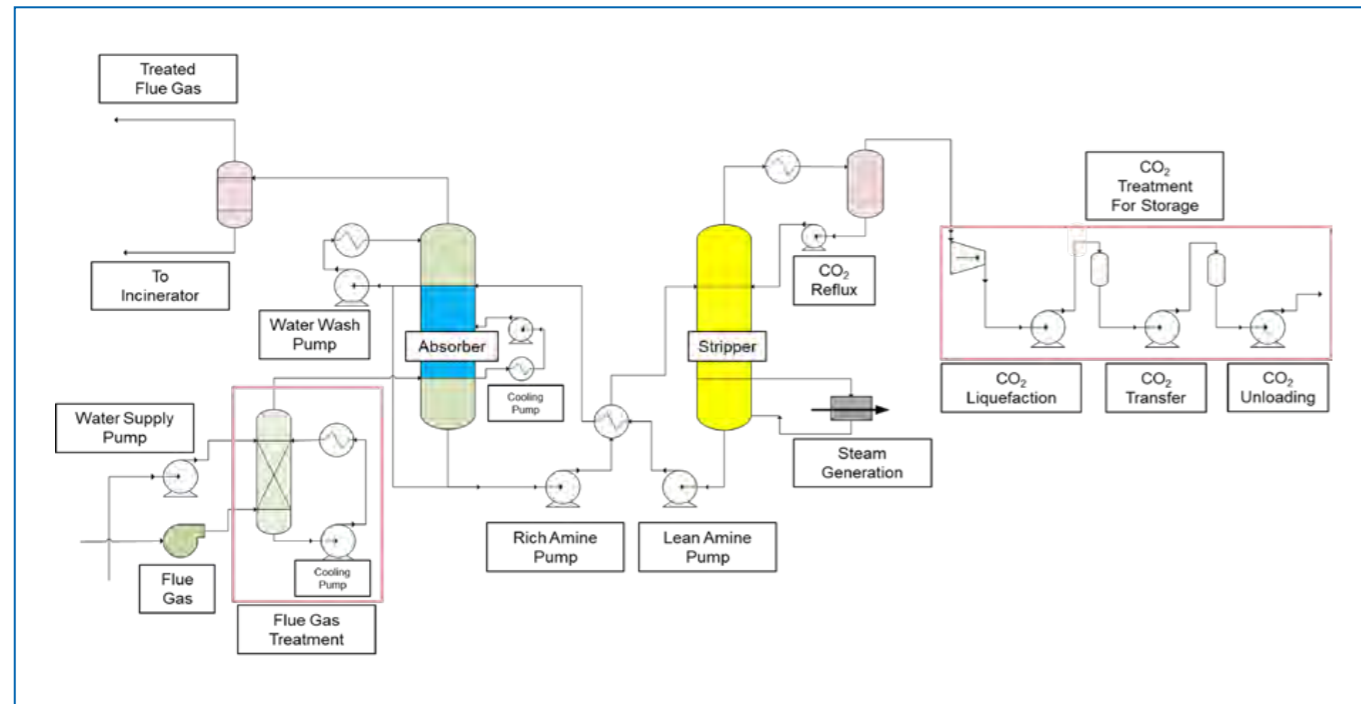

Figure 4 Schematic of waste-to-energy plant fitted with carbon capture - amine Based Solvent

Applications \ Pump Type	Flue Gas Treatment	Post Combustion	Pre-Combustion	Oxyfuel	CO2 Transport & Storage	Liquid H2
Water Intake	✓	✓	✓	✓	✓	
Water Circulation	✓	✓	✓	✓	✓	
Water Cooling	✓	✓	✓	✓	✓	
Solvent Handling		✓	✓			
Steam Power Generation		✓	✓	✓		
Black Water Handling			✓			
District Heating				✓		
CO2 Transport					✓	
CO2 Storage					✓	
HP Liquid H2						✓



# STORAGE







**SUMMARY**

Dril-Quip® is actively supporting global goals for environmental sustainability. We have applied our extensive expertise and capabilities as a leading manufacturer of cost-effective drilling and production products for the world’s most challenging oil and gas wells to develop offerings that enable the economical, reliable transportation and storage of CO<sub>2</sub> offshore.

Our ‘shore-to-seabed’ solutions save time and money, minimize operational and environmental risks, and reduce carbon footprint. Our technically and commercially proven CCS portfolio includes best-in-class Dril-Quip® wellheads

and the lightweight, compact Dril-Quip® SBTe™ SingleBore™ vertical tree system with patented VXTe™ self-aligning technology. A fully electric version of the SBTe™ is available to allow long-distance power distribution and management and faster data transfer for optimal digital monitoring.

Through partnerships with onshore and marine logistics and storage development companies that provide innovative transportation, logistics and storage technologies, Dril-Quip® can enable operators and storage licensees to store CO<sub>2</sub> efficiently and reliably for decades.

**BENEFITS**

- Economical shore-to-seabed solutions
- Lightweight, compact and Green By Design™
- Simple installation, operation, and monitoring
- Low maintenance, and reliable, enduring service
- Measurably reduces carbon footprint
- Seamlessly integrates with subsea templates

**DESCRIPTION**

Dril-Quip offers an extensive portfolio of field-proven differentiated products, including wellheads, connectors, trees, templates, manifolds, and flexible risers that enable customers to work safer, smarter, faster, and cleaner, while saving time and money. However, our game-changing SS15 RLDe™ wellhead and SBTe™ SingleBore™ vertical tree are essential to the successful injection and safe, long-term storage of CO<sub>2</sub> in depleted subsea oil and gas reservoirs and saline aquifers.

**Dril-Quip® SS15 RLDe™ Rigid Lockdown Subsea Wellhead System**

Field-proven in pressure and temperature extremes, Dril-Quip®’s SS15 RLDe™ System’s reliability is superior. It has been rigorously tested and surpasses industry standards for bending, tension, and load-carrying capacities. By eliminating the need for extra lockdown devices and enabling casing hanger and seal assemblies to be run in one trip, it saves significant time and money and lowers carbon emissions.

**Dril-Quip® SBTe™ SingleBore™ Vertical Tree System**

Our SBTe™ SingleBore™ Vertical Tree is the most economical tree system in the industry. Extremely lightweight and compact, the innovative SBTe™ can be deployed from any vessel (no rig required). Installation is simple and there are none of the complex interfaces and downtime associated with competitive trees.

By eliminating hardware, tooling, and operational steps, the SBTe™ tree enables operators to save significant time and money, reduce risks, and lower carbon emissions. Additionally, the Dril-Quip® SBTe™ is designed to handle the specific pressure and temperature considerations of CCS and can deal with CO<sub>2</sub> impurity levels as low as 92% by using either a combination of CRAs, or high toughness, low alloy steel with CRA cladding, depending on the application

Able to integrate seamlessly as part of a wider system, the SBTe™ can be incorporated into a template arrangement, attached to a marine buoy for injection purposes, or hooked up to flexible risers and attached to monitoring equipment as needed. It is well-suited to be an integral part of the storage and injection infrastructure and is available in both hydraulic and electrical models.

Dril-Quip® has designed, engineered, and manufactured an extensive portfolio of lightweight, compact, configurable products that when combined with the innovative offerings of our world-class partners, bring exceptional value to every project. Dril-Quip® is the optimal choice technically and commercially for all your shore-to-seabed CO<sub>2</sub> needs.

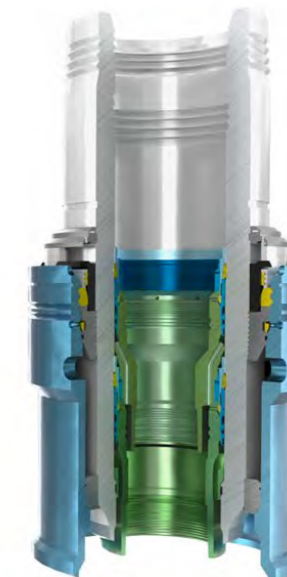
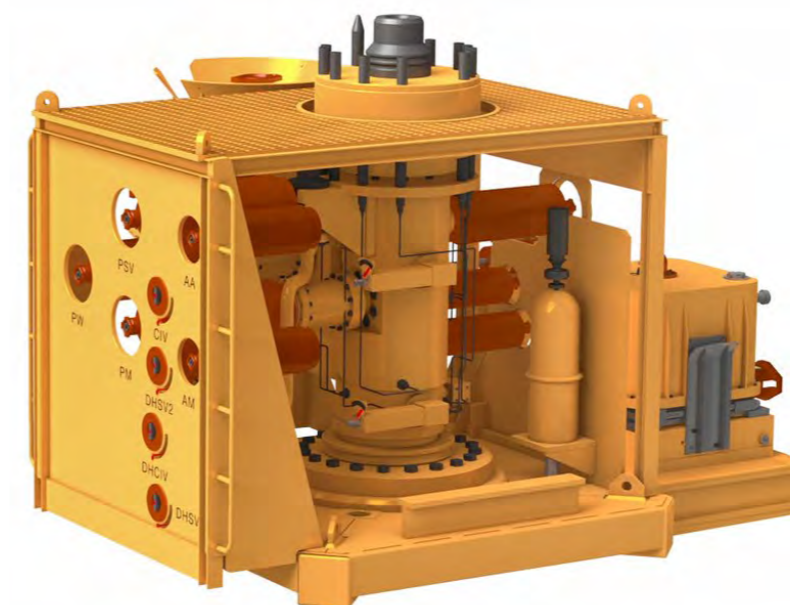





**YOUR BEST LOW COST SOLUTION FOR BEATING THE HIGH COST OF CORROSION AND EXTENDING THE LIFE OF YOUR TUBULARS!**

### SUMMARY

As CCUS projects are driven by the common goal of reducing global carbon emissions, the technologies employed in these projects have a critical role to play in achieving this goal. In several cases, existing ageing infrastructure from oil or gas field projects is repurposed for injecting CO<sub>2</sub> for up to five more decades. Maxtube provides a technology that contributes to increasing the longevity of the asset while reducing the cost and overall carbon footprint of the project.

Maxtube Limited are the proud owners of Duoline Technologies in the United States. Duoline are the pioneers of Fiberglass (GRE) Internal Lining systems, used to prevent corrosion in downhole tubulars. Over 110 million feet of Duoline GRE lined tubing has been installed in over 55,000 wells worldwide.

### What is Duoline 20 GRE Lined Tubing?

Duoline 20 is a Glass Reinforced Epoxy (GRE) composite liner, which is installed inside steel tubing to protect it from corrosion due to CO<sub>2</sub>, free O<sub>2</sub>, H<sub>2</sub>S, chlorides, water, and other constituents which may exist in the process fluids. This tubing is used downhole in injection and production wells. Duoline GRE also mitigates solid deposition inside the tubing.

Tubing made Carbon steel, lined with Duoline 20 GRE, can be utilized instead of expensive chrome and higher alloy steel grades, which are often the appropriate material for resistance to CO<sub>2</sub>.

Duoline 20 GRE Lined tubulars have been successfully employed in a variety of applications where they have been exposed to extreme process conditions – high temperatures, high pressures, high concentrations of dissolved gases, high chlorides, and high flow rates as well as mechanical “abuse” during multiple downhole interventions. The success of the technology is based on extensive testing and trials conducted by operators worldwide over five decades.

Duoline GRE liners are a proven flow assurance enabler. Benefits derived from the properties of the system include elimination of solid deposition, higher flow rates, reduced frictional losses and higher fluid temperature retention. These are attributed to the smoother surface of the Duoline GRE compared to steel, as well as the added insulation provided by the layers of grout and GRE. Enhanced flow assurance allows a more consistent, uninterrupted injectivity rate.

Duoline GRE has been proven to withstand:

- Temperatures from -51 °C (-60 °F) to 144 °C (291 °F)
- More than 300,000 ppm chlorides
- 100% wet and dry CO<sub>2</sub>
- Over 18,000 psi pressure

Duoline 20 has been a workhorse in CO<sub>2</sub> injection wells since 1984. This track record provides significant experience for knowledge transfer into material selection for carbon injection and utilization downhole in global CCUS projects.

### BENEFITS

There are two distinct contributions that Duoline 20 GRE lined tubing can make to reducing the carbon footprint of a CCUS project.

- Firstly, Duoline 20 GRE lining provides a corrosion barrier which protects carbon steel tubing for decades. The combined system costs a fraction of chrome and higher alloy steel tubing. Additionally, unlike sensitive alloy steels, Duoline GRE liners will offer consistent corrosion protection irrespective of contaminants in the flue gases from different industrial sources over the life of the project.
- Secondly, eliminating the use of chemicals for corrosion inhibition means eliminating carbon emissions from chemical manufacture, transportation, and injection into the wells over the life of the well.

The above benefits of applying Duoline 20 GRE Lined tubing in CCUS applications enable significant reductions in Capex and Opex over the lifecycle of the wells. This in turn enhances the overall viability of the project.





## DUOLINE 20 FIBERGLASS (GRE) LINED TUBING IN CO<sub>2</sub> INJECTION AND SEQUESTRATION

# MAXTUBE LIMITED

CONTACT

A. Fernandes & G. Radhakrishnan  
Email: [ccs@maxtube.com](mailto:ccs@maxtube.com)  
Web: [www.maxtube.com](http://www.maxtube.com)

### DESCRIPTION

The Duoline 20 Lining system consists of a fiberglass reinforced epoxy resin composite liner inserted inside low alloy carbon steel tubing with a cement grout. The grout transfers fluid pressure directly to the steel. The ends of the liner are protected from mechanical damage by end caps known as flares. A polymeric Corrosion Barrier Ring (CBR) extends the corrosion barrier across the coupling between two adjacent flares.

#### Duoline 20 GRE Lined Tubing in CO<sub>2</sub> Injection and Sequestration

The first miscible CO<sub>2</sub> Injection EOR project in Canada began in 1984 in the Joffre Viking Tertiary Oil Unit by Vikor Resources and the Alberta Oil Sands Technology and Research Authority. This is the first known successful application of fibreglass lined tubing to combat CO<sub>2</sub> corrosion.

Since then, Duoline 20 has been used extensively by Equinor, ExxonMobil and Oxy in CO<sub>2</sub> injection wells. In the United States, nearly 20 million feet of Duoline GRE Lined tubing has been used in CO<sub>2</sub> sequestration and injection. In 1996, Statoil were among the first to use Duoline GRE Lined Tubing in offshore Water Alternating CO<sub>2</sub> (WAG) wells in Europe.

Duoline 20 has since become the gold standard for tubing material in CO<sub>2</sub> injection wells, CO<sub>2</sub> WAG wells, carbonated water injection wells and hydrocarbon producers with high CO<sub>2</sub> concentrations. Duoline GRE has been tested and field-proven to withstand 100% CO<sub>2</sub> (wet and dry) and low pH solutions from dissolved CO<sub>2</sub> for decades.

Duoline 20 GRE lined tubing offers attractive savings compared to capital intensive high-chrome materials, such as 25CrSDSS and 28Cr, that are often the metallic selection for CO<sub>2</sub> applications.

While CCUS projects depend on dehydration of the CO<sub>2</sub> gas to prevent corrosion, it is undoubtedly challenging to maintain the 100% absence of moisture downhole. There are concerns around the impact of residual water from the reservoir during possible shut-in of CO<sub>2</sub> injection wells. In such cases, the dehydration of the gas will prove ineffective in combatting corrosion downhole. This risk necessitates a pre-emptive corrosion prevention strategy.

Over the life of CCUS projects, it is expected that the injected gas may be contaminated with NO<sub>2</sub>, SO<sub>2</sub> and other contaminants from flue gases generated at various industrial sources. The performance of metallic alternatives is sensitive to variations in the composition of process fluids. Duoline GRE liners, on the other hand, will offer consistent corrosion resistance irrespective of variations in constituents over the life of the project.

The selection of Duoline GRE lined tubing provides added insurance against potential process interruptions on the surface. For instance, any disruption to surface facilities for dehydration or treatment of the injected gas will not interrupt CO<sub>2</sub> injection if the material used downhole is able to withstand all corrosive elements. It is also noteworthy that repairs due to avoidable downhole failures are far costlier and time-consuming than repairs on the surface. Such cases justify the added insurance of Duoline GRE lining of tubing.

The above points demonstrate how Duoline GRE enhances the integrity and flow assurance of CO<sub>2</sub> injection systems thereby reducing the overall carbon footprint of the project. Duoline GRE Lined tubing offers substantial value to the overall economic and environmental viability of CCUS projects. Whether the well is completed onshore or offshore, platform or subsea, Duoline GRE lining is a single solution for tubing corrosion prevention and flow assurance.

#### Industry and Regulatory Authority Endorsements

Duoline GRE liners have been tested extensively for resistance to exposure to a variety of industry chemicals, full-scale combined loading inside tubing, pressure cycling, high erosional velocities, fatigue, and durability when exposed to downhole, coiled tubing and wireline, interventions.

Saudi Aramco, Shell, BP, Eni, and Statoil have conducted tests to confirm the viability of Duoline 20 GRE lined tubing as an alternative to chrome alloy steels.

Eni have performed several tests to qualify Duoline 20 GRE Lined tubing specifically for gas-well applications. These include tests to confirm the erosion resistance and mechanical properties of Duoline GRE which proved that its fatigue resistance is about nine times higher than

super-duplex stainless steel. Direct impact and straight pipe test results showed a very good resistance of Duoline GRE comparable to that of a Nickel Alloy 625 sample under similar conditions. These tests verified the erosional resistance of Duoline GRE essential for use in high velocity gas wells.

Duoline GRE has been used in wells with bottom hole temperatures up to 145 °C (293 °F) and has also been tested for resistance to temperatures as low as -51 °C (-60 °F). The resistance of Duoline GRE to temperature swings is particularly relevant considering the phase change sensitivity of CO<sub>2</sub> relative to temperature and pressure.

Operators have tested the compatibility of the Duoline 20 GRE Lining System with several families of premium connections. These confirm that the Duoline's GRE lining process and system components do not affect the connection dimensions, torque values and gas sealability. Duoline 20 GRE Lining systems have been applied on pipes with premium connections from Tenaris, Vallourec, JFE, Voest Alpine and TMK, among others.

In the US, experience and good practices recorded in the field of CO<sub>2</sub> injection are documented as regulatory alternatives and operating practices for the geological sequestration of CO<sub>2</sub> by the United States' Environmental Protection Agency (USEPA). Federal Requirements under the Underground Injection Control (UIC) Program for CO<sub>2</sub> geologic sequestration wells, are codified in the US Code of Federal Regulations, known as the Geologic Sequestration Rule, which establishes a new class of injection well (Class VI) and sets minimum technical criteria for these wells for the purpose of protecting underground sources of drinking water (USDWs). Proper well construction is necessary to ensure that CO<sub>2</sub> is safely injected into and contained within the targeted injection zone for the protection of USDWs. This guidance describes the construction and operating requirements for an approved Class VI injection well. GRE lined tubing is well accounted for in this document.

#### Value addition from flow assurance benefits

Duoline GRE retains its surface smoothness over its life. This has proven to retard, and even eliminate, the nucleation and subsequent deposition of solids such as scales, paraffins and hydrates on its surface hence enhancing flow assurance in wells.

Flow assurance benefits derived from Duoline 20 GRE Lining have also been attributed to the thermal insulation provided to the steel by the fiberglass and grout. Eni and Pertamina have published findings of higher temperature retention in wells with Duoline GRE lined tubing compared to bare steel tubing.

For completions requiring higher levels of thermal insulation, Duoline can engineer a lining solution compatible with premium connection Vacuum Insulated Tubing (VIT) to combine superior corrosion resistance with superlative thermal insulation.

The benefits of Duoline GRE lining system have also been applied to flowlines. Since 2008, Eni, Shell, and Apache subsidiaries have been using Duoline GRE lined, API and Premium connection, tubing to construct flowlines used for the transportation of hydrocarbons and water. While standalone GRE systems are available for flowline construction, the presence of steel reinforces the pressure bearing capabilities of the flowlines. In a worldwide first, Shell constructed a high-pressure flowline network using premium connection tubing. In such a system, the combination of the metal-to-metal seal in the premium connection tubing, and the Duoline GRE backed by the steel body of the pipe, ensure that there is no permeation of dissolved gases through the flowline into the atmosphere.



# FULL VALUE CHAIN







## SUMMARY

The Chilled Ammonia Process (CAP) was developed to address the challenges of removing carbon dioxide from low-pressure flue gases, which were generated by fossil-fuel-based power plants and industrial emissions points, such as coal-fired power plants, waste-to-energy power plants, biomass power plants, cement plants, refineries, and petrochemical complexes.

CAP is a post-combustion carbon-capture process that uses a non-proprietary solvent formulation based on ammonia. Ammonia is a low-cost, inorganic commodity chemical, readily available on the global market from multiple sources and not bound to any specific supplier. It is also stable, tolerant to flue gas contaminants and typically exhibits very low and controllable loss in the CAP process. Moreover, green ammonia (produced from green hydrogen) could be used instead of conventional ammonia in the CAP process.

Amine-based solvents have a tendency to degrade as a result of exposure to hot environments (thermal degradation), in the presence of oxygen (oxidative degradation) and in acid gas reactions (such as  $\text{NO}_x$ ).

The degradation results in a reduction of performance, solvent loss, equipment corrosion and the generation of volatile degradation compounds that are emitted into the treated flue gas, including nitrosamines, which are known carcinogens. Such degradation phenomena are absent for CAP, as the process uses an ammonia-based solvent, which is inorganic. CAP has the added advantage of being able to regenerate  $\text{CO}_2$  at elevated pressure, resulting in reduced energy costs to liquefy or further compress the  $\text{CO}_2$  downstream.

CAP has been validated at several test facilities with a design capacity of up to 100 ktpa  $\text{CO}_2$ , treating flue gases generated by oil boilers, coal boilers and industrial off-gases. A CAP plant designed to capture up to 80 ktpa  $\text{CO}_2$  has been operated at Test Centre Mongstad (TCM) in Norway for 2 years, where it demonstrated low specific thermal energy consumption of 2.6 GJ/ton  $\text{CO}_2$  on refinery cracker offgas (12.5 -16.0%  $\text{CO}_2$ ). The testing at TCM also demonstrated CAP's ability for quick start-up, low ammonia emissions, high  $\text{CO}_2$  product purity and meeting targeted  $\text{CO}_2$  capture rates.

## BENEFITS

- Demonstrated low specific thermal energy consumption of 2.6 GJ/ton  $\text{CO}_2$
- Uses ammonia, a commodity chemical that is easily procured and not bound to a specific supplier
- Stable reagent. Unlike amine-based solvent systems, it does not suffer from thermal and oxidative degradations
- Flexible for process integration. Allows efficient-direct high temperature waste heat utilization or direct electrical heating without the degradation of solvent performance
- Tolerant towards oxygen in flue gas and towards contaminants such as  $\text{SO}_x$  and  $\text{NO}_x$
- Produces less harmful emissions and potentially useful by-products
- Regenerates  $\text{CO}_2$  at high purity (> 99.5%) at elevated pressure, thus requiring less compression energy for the downstream  $\text{CO}_2$  product

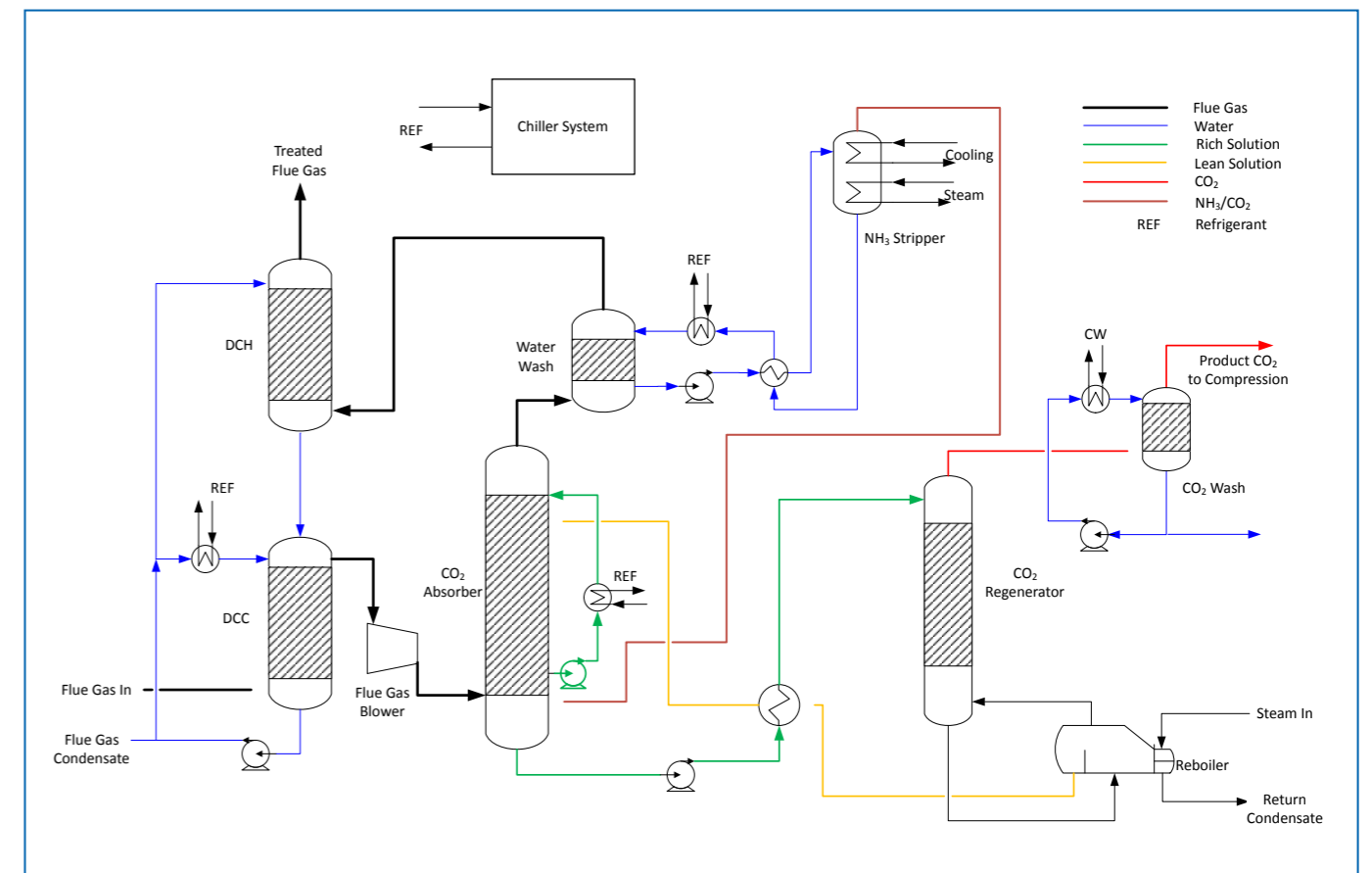



### DESCRIPTION

The Chilled Ammonia Process (CAP) uses an ammoniated aqueous carbonate solution to absorb CO<sub>2</sub> from the flue gases at ambient pressure and low temperature. Unlike other technologies, the functionality of the ammonium solution is not affected by oxygen and easily purged of heat stable salts formed by trace acidic components, which may pass dedicated flue gas preconditioning steps. Moreover, since its gaseous emissions and liquid waste streams are non-toxic, no additional treatment facilities are required.

A simplified process flow diagram of the CAP technology is shown in the accompanying figure and the process can be described as follows.

Inlet flue gas first undergoes cooling via a direct contact cooler (DCC) that enables the contact of gas with cooling and chilled water to lower the flue gas temperature to a suitable level (typically below 15 °C), which is needed for the CO<sub>2</sub> absorption process and water balance. Most of the water vapour contained in the flue gas is removed in this step, which reduces the volumetric gas flow and increases the CO<sub>2</sub> concentration. For conventional amine-based solvents, a flue gas pre-treatment step is required, which is typically integrated with the DCC to reduce NO<sub>x</sub>, SO<sub>x</sub> and other contaminants in the flue gas to very low levels to decrease degradation and formation of heat-stable salts when the flue gas interacts with the solvent. However, for CAP, this pre-treatment step is typically not required as the ammonia-based solvent is able to tolerate these flue gas contaminants. Strong acids such as SO<sub>x</sub> react with ammonia and form heat-stable salts, which are withdrawn from the system as an aqueous by-product.

Cooled flue gas from the DCC enters the bottom of the absorber column, where it is washed counter-currently with lean ammonia-based solvent (orange line). CO<sub>2</sub> is selectively removed from the flue gas in a chemical absorption process using the alkaline lean solvent. The lean solvent is a solution comprising ammonia, water and CO<sub>2</sub> where different species (ammonium carbamate, ammonium bicarbonate, ammonium carbonate and a limited amount of free ammonia in an aqueous solution) are in equilibrium. The dissolved ammonia species react with CO<sub>2</sub> from the flue gas in the absorber by shifting the species' equilibria towards bicarbonate. The CO<sub>2</sub>-rich solvent (green line) leaves at the bottom of the absorber and is sent to the regenerator section, where it is heated to a temperature high enough for CO<sub>2</sub> to be released from the solvent. A reboiler located at the bottom of the regenerator column provides the heat to the solvent. The heating source is typically steam, although hot oil or heat from a direct-fired or electric heater can also be used due to the absence of thermal degradation.

Heat is imparted to the solvent to shift the equilibria to ammonia-rich species releasing the absorbed CO<sub>2</sub>, which leaves at the top of the regenerator column. Compared to the amine-based post-combustion technologies that regenerate CO<sub>2</sub> at near atmospheric pressure, CAP regenerates CO<sub>2</sub> at an elevated pressure (14 bar - 25 bar(a)), which reduces the downstream compression power requirements.

Regenerated lean solvent (orange line) is returned to the absorber after undergoing cooling through heat exchange with the cold rich solvent in the lean-rich heat exchanger, which simultaneously heats the rich solvent. This is an important heat integration step that significantly reduces the reboiler heat requirement.

Treated flue gas exiting the top of the absorber column contains residual CO<sub>2</sub> and ammonia, which is recovered with a water wash step to prevent unacceptable emissions of ammonia into the atmosphere. After the water wash step, the flue gas is routed to a flue gas heater. A guard system is integrated with the flue gas heater, which relies on the injection of sulfuric acid to neutralize any residual ammonia, converting it into ammonium sulphate. The flue gas is reheated with warm water condensed from the DCC, which serves to raise the temperature of the final treated flue gas to a temperature high enough to be released into the stack and to optimize the water balance of the system.







### SUMMARY

Baker Hughes uses the Mixed-Salt Process (MSP) for CO<sub>2</sub> capture under license from SRI International. SRI International received support from the US Department of Energy's Office of Fossil Energy and National Energy Technology Laboratory (NETL) for the development of this technology.

MSP is a post-combustion carbon-capture process that uses a novel solvent formulation, which is based on potassium carbonate and ammonium salts. Both chemicals are low-cost, inorganic commodity chemicals, and readily

available on the global market from multiple sources. The inorganic solvent used by MSP is tolerant to flue gas contaminants (such as SO<sub>x</sub>, NO<sub>x</sub>, and O<sub>2</sub>), unaffected by thermal and oxidative degradation, results in lower emissions, lower toxicity, and higher CO<sub>2</sub> regeneration pressure compared to conventional amine-based solutions. MSP has been demonstrated at the capacity of 0.25 tpd at the SRI campus in Menlo Park, USA. A 10 tpd pilot-scale plant to demonstrate the MSP technology at the University of Illinois is currently in the design phase.

### BENEFITS

- Reduced reboiler energy consumption of 2.0 – 2.3 GJ/ton CO<sub>2</sub>
- Uses inexpensive, industrially available chemicals (potassium and ammonium salts)
- Stable reagent. Unlike amine-based solvent systems, it does not suffer from thermal and oxidative degradation
- Tolerant towards oxygen in flue gas and to contaminants such as SO<sub>x</sub> and NO<sub>x</sub>
- Regenerates CO<sub>2</sub> at elevated pressure, thus requiring less compression energy for the downstream CO<sub>2</sub> product
- Reduced auxiliary electricity loads

### DESCRIPTION

MSP is a post-combustion technology that is applicable to a wide range of flue gases. It uses a blend of ammonium and potassium-based salts to absorb CO<sub>2</sub> from flue gases at ambient pressure and temperature. The stability of the inorganic solvent used by MSP's ammonium solution is not affected by oxygen and shows high tolerance to acidic trace components present in the incoming flue gas. The process is characterized by very low emissions and produces little-to-no toxic waste.

A simplified process flow diagram of the MSP technology is depicted in the accompanying figure and the process can be described as follows.

Inlet flue gas first undergoes cooling to 20 - 30 °C in a direct contact cooler (DCC) and subsequently enters Absorber 1, where it contacts the mixed salt solvent counter-currently. The mixed salt solvent in Absorber 1, which has a higher concentration of ammonium-based species than potassium-based species (high ammonia/potassium ratio), performs the bulk removal of CO<sub>2</sub>, absorbing 60-80% of the CO<sub>2</sub> in the flue gas. The remaining CO<sub>2</sub> is absorbed in Absorber 2, which operates with the mixed-salt solvent with a lower ratio of ammonium-based species to potassium-based species than that of the solvent feed of Absorber 1. Absorber 2 performs the trim removal of CO<sub>2</sub> to achieve an overall CO<sub>2</sub> capture rate of more than 90% and reduces the ammonia slip from Absorber 1. A water wash located at

the top of Absorber 2 further reduces the ammonia content in the treated flue gas to ensure that it meets the ammonia emission limits.

Both absorbers operate with liquid recycle using heat exchangers to remove the heat of reaction and keep the solution at the optimum temperature for efficient absorption and minimum ammonia slip. The CO<sub>2</sub>-rich solvent collected from the absorbers is sent to the regenerator for regeneration via an integrated rich-lean heat exchanger network that is designed to recover sensible heat.

Heat is supplied to the regenerator via a reboiler located at the bottom of the column. The increase in temperature releases CO<sub>2</sub> as a gas and regenerates the mixed-salt solvent to be returned to Absorber 1 and Absorber 2. CO<sub>2</sub> is released at an elevated pressure of 10 - 20 bar(a) from the regenerator column, which serves to reduce the downstream CO<sub>2</sub> compression requirements.

The CO<sub>2</sub>-lean mixed salt solvent is drawn from the lower-middle stage of the column and sent back to Absorber 1 to perform bulk CO<sub>2</sub> removal. Near the bottom of the regenerator where the temperature is higher, ammonia is vaporized, resulting in a lean solvent with low ammonia/potassium ratio, which is returned to Absorber 2 where it performs the trim removal of CO<sub>2</sub> and reduces ammonia losses.

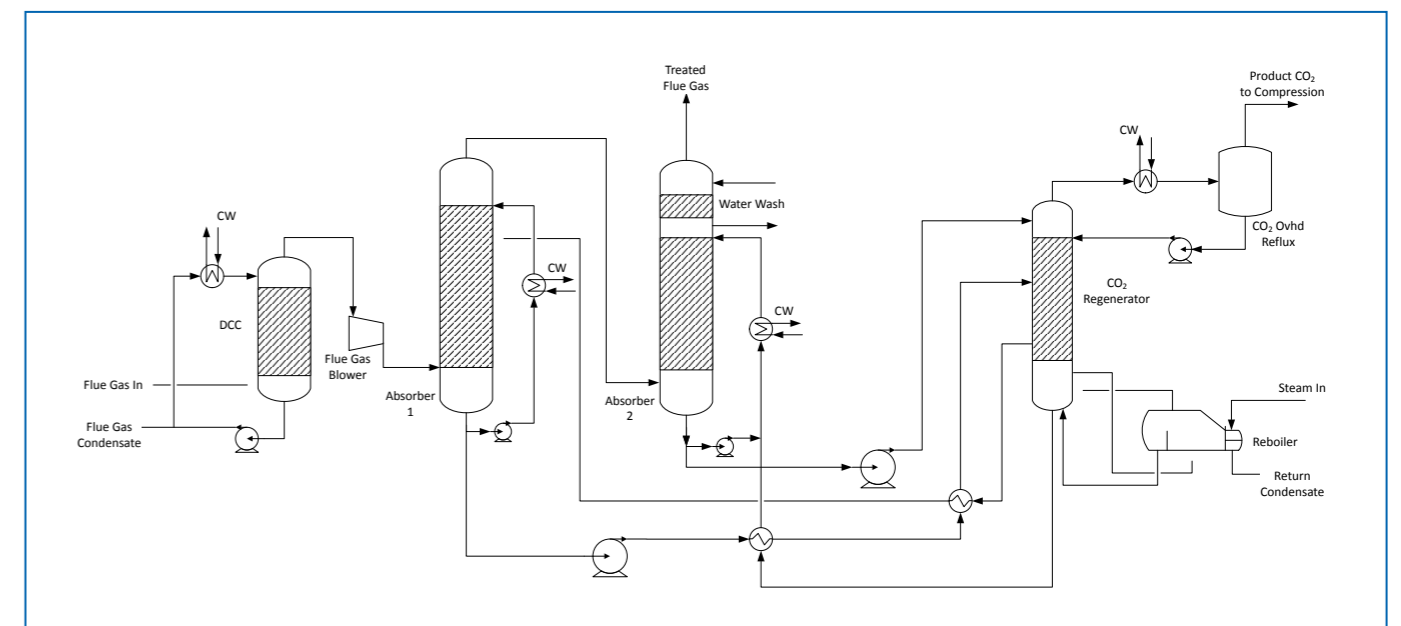



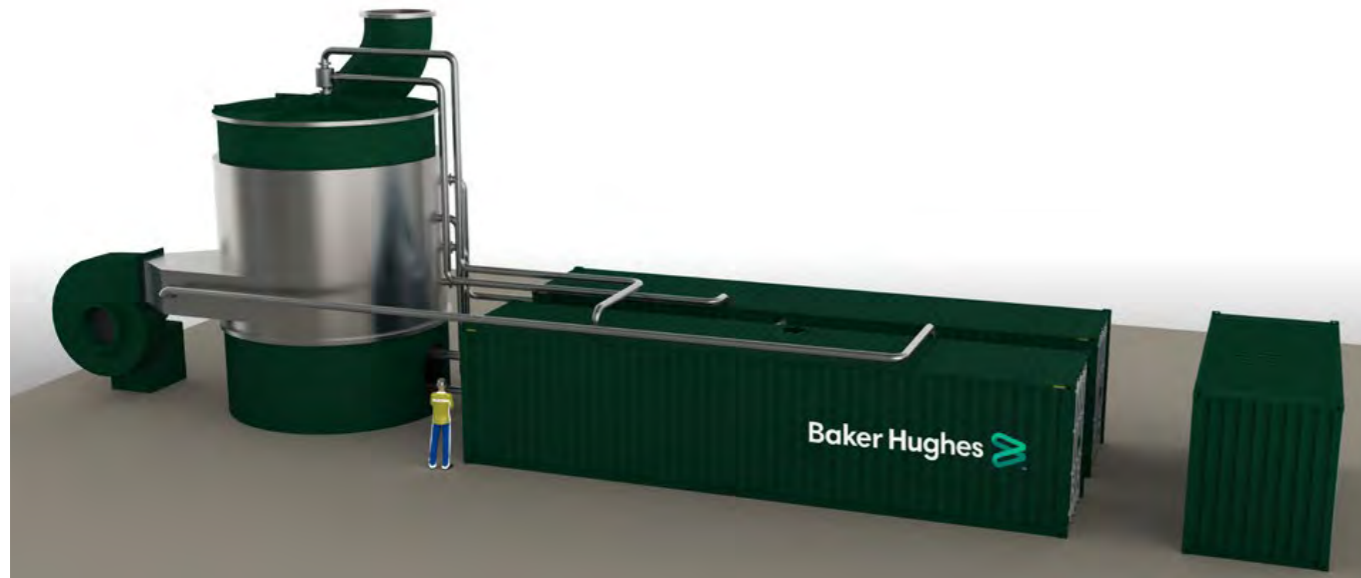

## SUMMARY

Baker Hughes acquired Compact Carbon Capture (CCC), a pioneering technology development company based in Bergen, Norway, that specializes in compact carbon capture solutions. CCC employs the rotating packed bed technology, a novel process intensification that utilizes centrifugal acceleration to intensify mass transfer, thereby reducing the equipment size and cost. CCC's technology is solvent-agnostic and in principle, can be applied to any solvent developed for post-combustion carbon capture.

Using its rotating packed bed technology, CCC drastically

increases the vapor-liquid contact area, overcoming the traditional hydraulics limitations. Compared to traditional solvent-based systems using static equipment, CCC's enhanced mass transfer results in reduced residence time in both the absorber and the regenerator, thereby requiring much smaller equipment.

CCC is currently validated at the lab-scale (CO<sub>2</sub>) at Equinor's test facilities (PLAB) in Porsgrunn, Norway. Steps for further advancement are ongoing, with a demonstration plant at the 30 tpd scale currently in the planning stage.

## BENEFITS

- Up to 75% reduction in the overall size of the capture plant compared to conventional technologies
- Up to 50% reduction in capital expenditure compared to conventional technologies
- The possibility to reduce operating expenses significantly by using new, viscous, and efficient solvents
- Reduced lead time through standardized and containerized production, design thinking for simplified logistics, and decreased demand for civil works
- Modular scalability to increase the deployment speed of CO<sub>2</sub> capture equipment. For example, it is possible to invest in partial capture right away and increase the capture capacity at a later stage.

## DESCRIPTION

Compact Carbon Capture has transformed the process equipment used in post-combustion carbon capture by introducing rotation and high G-forces to capture CO<sub>2</sub>. The G-forces are created in several cross-flow rotating packed beds. CO<sub>2</sub>-lean solvent is distributed from the inner axis and horizontally flung outwards in the direction of the wall of the column, while the flue gas moves vertically from the bottom to the top. Mass transfer takes place between the flue gas and the solvent in a cross-flow type arrangement.

Due to the rotation of the packed bed within the column that induces high centrifugal forces (60-100 G-force), the solvent is accelerated when it hits the packing structure, forming small droplets. This generates a large vapor-liquid contact area compared to traditional static mass transfer technology that rely on gravity. The larger contact area between gas and liquid results in a faster mass transfer of CO<sub>2</sub> from the flue gas into the solvent droplets, resulting in a much shorter absorber column height compared to conventional, static absorber columns.

The high G-forces allow for the application of highly viscous solvents that improve the process efficiency. Higher solvent concentration results in higher absorption rates. When this is combined with the compactness introduced by the process intensification, a considerably lower solvent volume is needed, and the pump capacity needed for solvent transfer is reduced.

The compact stripper is a combined reboiler and desorber unit that can operate at higher pressures and handle highly viscous solvents. High-speed rotation of the stripper unit introduces turbulence and high G-force to the solvent regeneration, which are advantageous for mass and heat transfer, resulting in very compact equipment. The rotating bed desorber/stripper can be described as a lightweight pressurized shell-and-tube heat exchanger where the "hot-side" tube bundle rotates to generate the centrifugal force required to produce small solvent droplets. Instead of a static regenerator column with attached reboiler in a conventional solvent-based system, CCC will have a single compact rotating bed/flash drum that both heats the rich solvent and flashes off CO<sub>2</sub> to generate a high purity (>99%) CO<sub>2</sub> product stream.





## SUMMARY

Leveraging its extensive domain expertise in compression and pumping technologies from decades of experience in related areas such as urea and liquefied natural gas, Baker Hughes has the comprehensive capabilities to make the compression of CO<sub>2</sub> safer, easier and more cost-effective for CCUS applications. Baker Hughes has focused its attention on customizing complete compression trains suited for the unique characteristics of CO<sub>2</sub> so that these can operate more efficiently and minimize the overall parasitic power consumption of CCUS processes.

Baker Hughes offers a range of products, including reciprocating, centrifugal and integrally geared CO<sub>2</sub> compressors, as well as centrifugal CO<sub>2</sub> pumps. These technologies have undergone years of proven in-field performance. Baker Hughes has also continued to develop and optimize these technologies at our global research centres, performing extensive testing in both laboratory and in-field environments before launching these products for our customers' use.

## BENEFITS

- Reduced compression train parasitic power consumption
- Optimized high compression ratio across a wide range of flow rates
- Optimum rotor balance for low vibration level
- Easily accessible components for maintenance
- Automatic capacity control and safety system to reliably match any operating condition
- Reduced lead time through standardized and containerized production, design thinking for simplified logistics, and decreased demand for civil works

## DESCRIPTION

The operating envelope for CO<sub>2</sub> delivery to sequestration sites is very broad in terms of volumetric flow and delivery pressure. It ranges from several thousand m<sup>3</sup>/h at relatively low pressures, up to a few hundred m<sup>3</sup>/h at extremely high pressures (700-800 bar). Baker Hughes offers a range of customizable CO<sub>2</sub> compression systems, depending on site conditions such as delivery pressure, temperature, cooling sources and gas composition. General configuration options for CO<sub>2</sub> compression are shown in the table below.

PRESSURE	CONFIGURATION OPTIONS
< 200 bar	In-line compressor Integrally geared compressor + pump
> 200 bar	In-line compressor + HP pump Integrally geared compressor with MP pump + HP pump

MP = medium pressure; HP = high pressure

Baker Hughes has optimized the configuration of the overall CO<sub>2</sub> compressor-pump train for CCUS applications. This includes the selection of the intermediate pressure between the last compression stage and the pump suction with the goal of decreasing the total power consumption and cost.

### Integrally geared compressors

The main advantage of integrally geared centrifugal compressors are that coolers can be installed after each stand-alone stage. Baker Hughes' design features a bull gear and from one to four high-speed pinions, with one or two impellers mounted on each pinion shaft. Stand-alone stages optimize impeller speed and allow impellers to operate at higher peripheral speed and level of compression. Each stage can be fitted with inlet guide vanes to eliminate the need for recirculation for partial loads. The net result is a high efficiency operation that requires less work than an in-line compressor.

### In-line centrifugal compressors

Baker Hughes has supplied more than 200 in-line compressor units with discharge pressure within the range of 200 bar. The typical train arrangement includes a steam turbine or electric motor that drives a low-speed, horizontally split compressor, and a high-speed barrel compressor through an increasing gearbox, typically followed by a pump for CO<sub>2</sub> injection. For applications where the CO<sub>2</sub> stream contains H<sub>2</sub>S and water, Baker Hughes uses primarily stainless steel for improved corrosion resistance.

### Pumps

Baker Hughes' development of its high-pressure CO<sub>2</sub> injection pumps rely on the experience of over 1,000 multi-stage centrifugal pumps for liquefied gas applications. Our multistage barrel pump is a good fit for CO<sub>2</sub> applications, providing better overall efficiency compared with the in-line rotor configurations, thanks to its opposing back-to-back impeller configuration.



## SUREVIEW™ WITH COREBRIGHT™ OPTICAL FIBRE BAKER HUGHES



### SUMMARY

Reliable downhole measurement of well and reservoir parameters is imperative to the success of geological sequestration projects. Baker Hughes is uniquely positioned to holistically address the monitoring challenges. Baker Hughes leverages a broad portfolio of technology and experience across permanent downhole gauges, microseismic monitoring, wireline monitoring, and fibre optic solutions. Specifically, fibre optic monitoring is an effective solution to gather a range of real-time data downhole. These systems can provide distributed

temperature, acoustic & strain measurements, transmit point gauge data, and capture seismic measurements for use in vertical seismic profiling. The majority of traditional downhole fibre optic installations are intended for 10-20 years of hydrocarbon production life. However, the geological sequestration projects can require much longer service life. SureVIEW™ with CoreBright™ technology is a proprietary fibre optic cable design with industry-leading 40+ years of reliability and unique resistance to common hydrogen darkening failure.

### BENEFITS

- Collect multiple measurements with a single cable including distributed fibre optic sensing, pressure/temperature gauges for well integrity, compaction monitoring, and seismic data.
- Utilizes CoreBright™ hydrogen resistant fibres to limit the effects of hydrogen darkening
- Cable is clad with robust Inconel 825 corrosion-resistant nickel alloy for maximum protection against chemicals, abrasion, crimping and crush.
- Continuous cable with no orbital welds
- Fibre In Metal Tube (FIMT) utilizes continuous (splice-free) fibres throughout
- Equipped with excess fibre to ensure that no strain is transferred to the optical fibre core during deployment or operation. Excess fibre compensates for thermal expansion, as well as tubing stretch.

### DESCRIPTION

SureVIEW™ downhole cable by Baker Hughes uses CoreBright™ optical fibre, which leads the industry in hydrogen darkening resistance, a leading cause of failure for fibre optic systems over time. CoreBright™ fibre is constructed from pure silica that minimizes hydrogen darkening. The cable also includes a layer of hydrogen-absorbing gel. This combination provides the industry's best protection against hydrogen darkening.

Fabricating a downhole optical cable with the performance and reliability demanded by our industry requires a sophisticated understanding of fibre design, fibre coatings, cable manufacturing processes, and cable construction.

Fibres are typically coated, often with carbon, to prevent this hydrogen darkening. However, over time, this coating can break down or suffer from uneven application during manufacturing. A well applied coating will likely break down in about 20 years, particularly at higher temperatures (above 150 °C). CoreBright™ fibre offers its extended lifetime through a simple principle: instead of attempting to avoid hydrogen damage by trying to block hydrogen, CoreBright™ optical fibre avoids the hydrogen damage by preventing the reaction between the SiO<sub>2</sub> structure of the optical fibre and the hydrogen. In addition, Baker Hughes' fibre optic cables are fitted with hydrogen scavenging gels to further reduce darkening risk.

In this way, Baker Hughes' solution is unique: the fibre will not darken, and reliable readings over the full life of the installation are assured. Independent testing has concluded that CoreBright™ optical fibre is the only fibre in the industry that is suitable for harsh downhole environments over a long duration. It is the only known fibre that was designed for, and has demonstrated, long-term immunity to first and second-order hydrogen darkening effects.<sup>1</sup>

SureVIEW™ fibre optic cables, powered by CoreBright™ fibre, have been installed in over 300 wells worldwide. As of today, there are no instances of hydrogen darkening ever experienced. In addition, during high-temperature monitoring work performed by Baker Hughes for electrical submersible pumps where it is common practice to test the fibre as the pumps are pulled, the CoreBright™ fibre has

CONTACT

Gianluca Di Federico

Email: [gianluca.difederico@bakerhughes.com](mailto:gianluca.difederico@bakerhughes.com)

Web: [www.bakerhughes.com](http://www.bakerhughes.com)



maintained its mechanical and optical reliability in every instance. Proof-testing of the fibre showed levels that are typical of 'as-built' condition and demonstrated negligible changes in optical loss profiles.

High reliability and longevity enable the use of fibre optic measurement in more applications particularly behind the casing where workover is likely impossible. Baker Hughes' SureVIEW™ downhole cable is expected to improve data quality and facilitate better decision-making in geological sequestration today.

<sup>1</sup> "tedTemperatures Under Hydrogen Conditions", SEAFOM Industry Meeting (Dec. 2012)





## SUMMARY

Well-known pressure and temperature are key to proper functioning throughout a CO<sub>2</sub> storage system. For most applications, the best way to monitor these parameters is with permanent downhole gauges (PDHGs). These gauges can be used as a standalone means of measurement or as calibration for a fibre optic-based or other extensive

measurement system. Baker Hughes leverages the quality and performance of the SureSENS™ line to execute integrated monitoring solutions that combine point gauges, fibre optics, along with periodic means of measurement such as wireline logging data.

## BENEFITS

- Provides superior reliability in long-life and/or demanding (high-pressure and high-temperature) applications
- Derives finest pressure/temperature measurement resolution attainable
- Deploys multiple gauge combinations on a single standardized carrier
- Eliminates the need for additional splices, increases reliability, and reduces installation time through unique construction configurations with fewer connections
- Deploys multiple gauges, flowmeters, and valve positions to provide redundant readings
- Serves as platform for future developments

## DESCRIPTION

The SureSENS™ QPT ELITE gauge for permanent downhole installations measures static and dynamic pressures and temperatures while introducing a step change in reliability and accuracy. The gauge is qualified for operation at pressures less than 35,000 psi (2,414 bar) and temperatures up to 225 °C (437 °F). The static and dynamic pressure information obtained can be used to determine the effects of injection and plume growth on monitoring wells, monitor injection characteristics, and provide input or validation to reservoir models. The SureSENS™ QPT ELITE gauge includes the new ELITE electronics package, built upon Baker Hughes' industry-leading STAR hybrid electronic package design. The ELITE electronics package incorporates an application-specific integrated circuit (ASIC), providing a new level of reliability to the industry. Baker Hughes provides three configuration options—single, dual, and triple gauge. The single-gauge configuration is an economical option that will also permit the smallest possible running diameter for a streamlined, slim-hole gauge carrier. A dual-gauge configuration provides isolated operational redundancy of electronics and transducer at any given installation point. Each gauge in a dual package operates individually, providing independent measurements for data redundancy and

integrity verification. The triple gauge option can offer redundancy or be ported to record three independent pressure measurements. The shorter carrier for a side-by-side triple-gauge assembly also retains a slim hole running outside diameter.

For applications requiring long active life and high data accuracy, even in demanding high-pressure/high-temperature type environments, the SureSENS™ QPT ELITE gauge system provides a flexible and reliable solution.

Being highly robust, the SureSENS™ QPT ELITE gauge maintains mechanical integrity by deep-penetration and high vacuum, electron-beam fusion welds, without the need for filler material. Only two fittings, the pressure port and the tubing encapsulated conductor (TEC), are required to interface the gauge with the carrier. The gauge pressure interface connection to the carrier can be externally tested in the direction in which it will experience pressure, eliminating the need for an internal pressure test tool. The TEC's primary seal is a dual metal-to-metal pressure-testable interface. The mechanical package is completely integrated into the gauge assembly, which eliminates the requirement for external Y-block components.



Gauge Carrier configured with QPT ELITE permanent downhole gauge



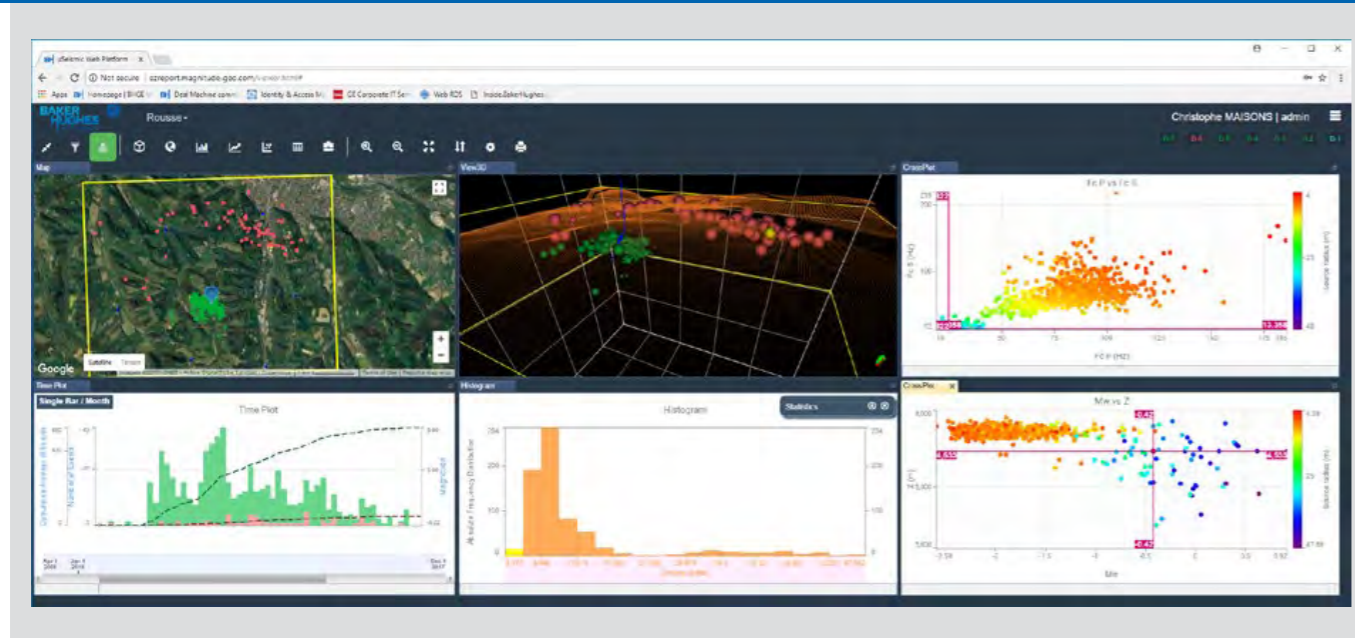

### SUMMARY

Monitoring seismicity is essential to guarantee the integrity of geological sequestration reservoirs and caverns. In terms of physical integrity, seismicity in the cap rock is an indicator of the risk of catastrophic failure. At the reservoir scale, seismicity at faults can identify the reactivation by fluid injection or that they provide a pathway to the surface for the stored fluids. With more public attention towards induced seismicity and environmental impact

of human activity, reputational integrity is becoming as important as physical integrity. It is therefore becoming essential to detect growing activity trends before critical situation happens to support operators' injection program. Baker Hughes provides the whole range of customized microseismic services and instrumentation to provide lifetime monitoring of CCS assets.

### BENEFITS

- Maximize storage capacity within safety limits
- Compliance with regulations
- Monitor structure integrity (cap-rock & faults)
- Distinguish induced versus natural seismicity
- Avoid water breakthrough

### DESCRIPTION

The range of the monitoring solution can be described in 3 distinct stages that can be performed as a whole or as independent services.

#### Network design

In this phase, consideration is given to the project's constraints (regulatory, geological, operational and logistical) and advanced modelling is used to determine the most cost-effective network that will meet the project's objectives. This network can consist of a specific technology (surface or downhole solutions with analogic geophone or fibre optics) to be deployed, but can also have a combination of them to benefit from their different capabilities.

#### Installation and maintenance

Baker Hughes ensures supply of all the required instrumentation: surface sensors, shallow buried sensors (100 m), borehole sensors, surface electronics, fibre optics, digitizers, and fully equipped seismic cabinets. Where not internally developed, Baker Hughes works with trusted suppliers with long-term relationships to develop reliable hardware (Mean Time Between Failures of more than five years) with advanced capabilities.

Baker Hughes installs and maintains all the instrumentation, including borehole sensors. The requirement for preventive maintenance is extremely low (one visit a year at most). This allows us to operate sites all over the world. Most of the sites are totally autonomous, relying on solar panels for power and 4G networks for communications.



#### Monitoring - Processing

A dedicated team of experts processes the data and reports on the seismicity through a dedicated web portal. The portal allows the operator to visualize the seismicity in two-dimensions (2D) or 3D along with the well trajectories and formation interfaces and offers statistical analysis capabilities. It also plays the monitoring network's state of health and expected sensitivity in real time. Pressure and/or flow rate curves can be displayed along with seismic rates to easily relate any seismic activity to its probable cause.

Automation of the process can be utilised to enhance the processing solution by adding 24/7 services such as traffic light systems that will alert the operator when critical seismicity is reached, and the prediction of the level of seismic risk for the upcoming hours using machine learning.

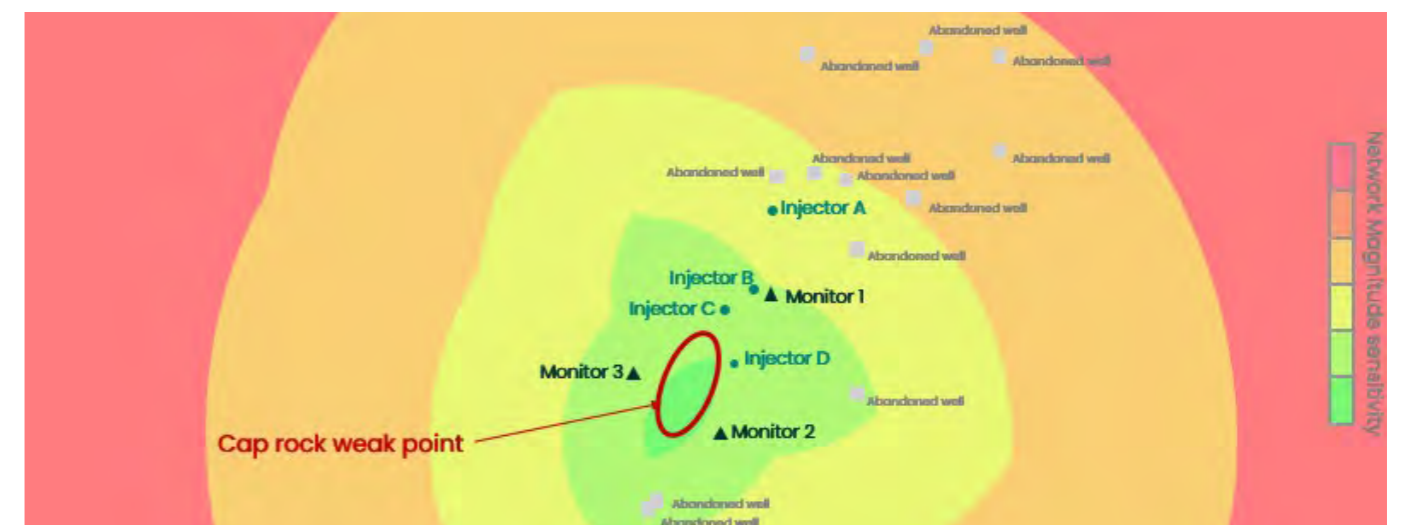



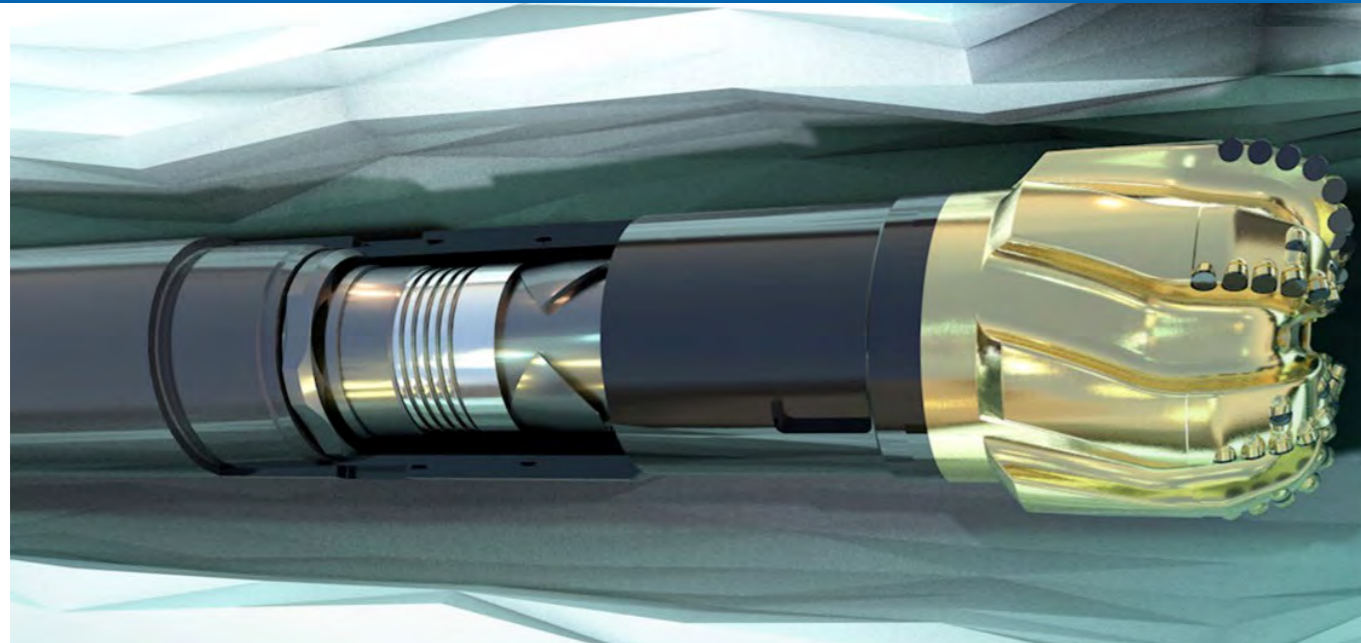

**SUMMARY**

Seal integrity is key to the success of any geological sequestration project. Along with the logging and measurement technology, taking physical cores is one of the best ways to characterize these structures. Core samples retrieved with traditional coring systems can often break and become jammed or lost in a hole. Jams and poor core quality can lead to re-runs that incur significant

additional cost. The CORTIVA™ coring system improves efficiency and de-risks core recovery through the use of a fully-closed and jam-mitigating core barrel. By combining these key features, CORTIVA™ shortens the time and costs required to cut and retrieve a core sample by ensuring the whole core section is retrieved safely in a single trip.

**BENEFITS**

- Core longer even in fractured or other jam-prone formations by neutralizing up to two jamming events
- Full-closure catcher completely seals inner tube to prevent loss even when the core is unconsolidated
- The HT30™ Max core barrel system delivers larger, longer samples than other systems
- Unobstructed 'slick' entry eliminates risk of jam at core's centre

**DESCRIPTION**

Core jamming during coring operations and/or loss of friable core material during trip-outs leads to additional coring runs, resulting in increased rig time and cost. Jams that occur inside the inner tube of a core barrel can often be mitigated by certain jam-mitigation techniques, allowing coring to continue. However, jams that occur in the core catcher, provoked by the mechanical interaction of the core with the catcher mechanism, would not be mitigated by such anti-jamming technologies. These typically occur in formations that are a mixture of fractured (jamming-prone) and friable rock. This type of complex, coring application demands technologies beyond what is currently available in the market. Competitors have either standalone jam mitigation systems for jam-prone formations, or full-closure catcher systems for unconsolidated/friable rock.

Baker Hughes combines the benefits of various technologies to improve the efficiency of coring operations in complex formations. With its CORTIVA™ full-closure system with jam mitigation technology, Baker Hughes combines the JamBuster™ jam mitigation coring system and the

HydroLift™ full-closure catcher system—industry standards for jam mitigation and recovery of friable rock to improve the efficiency and recovery of high-quality core in complex fractured and friable formations.

The Baker Hughes patented JamBuster™ system neutralizes jams inside the inner tube through concentric inner core barrel sleeves that automatically telescope if a core becomes jammed in the core barrel, allowing coring to continue without interruption. The HydroLift™ system efficiently recovers high-quality, intact core samples collected in soft, or unconsolidated formations. The system's slick, unobstructed entry eliminates the risk of jamming at the core catcher for the incoming core, while the full closure mechanism secures the core, thus preventing loss of friable/ loose formation during trip-out.

The CORTIVA™ full-closure system with jam mitigation technology is also integrated with HT30™ Max core barrel system to deliver an unmatched core size. It also reduces core acquisition costs by acquiring longer, high-quality core samples per run, even in harsh environments.







## SUMMARY

In geological sequestration, completion integrity for any well penetrating the target storage interval is key to maintaining storage integrity over the life of the project. Chemical corrosion inhibitors and reservoir's environmental factors can be damaging to elastomer seals over time. The most common sealing elastomers in the industry today often force a choice between effectiveness at low temperatures or chemical compatibility with corrosion inhibitors. Aptum™ seal systems, along with industry-

leading packers such as the Premier™ NXT removable production packer, perform at lower, more appropriate temperatures for CCUS and yet maintain excellent chemical compatibility and mechanical properties. With Aptum™ seals in the completion, operators can better protect their metal tubulars and equipment without fear of elastomer degradation.

## BENEFITS

- Delivers high performance across a wide temperature range
- Compatible in a range of environments including corrosion-inhibited fluids and reservoir fluids
- Resistant to sour conditions
- Single compound simplifies material recommendations and testing for well planning across all seals including packing elements, O-rings, and bonded seals
- Extends life of seal, further improving reliability
- Meets ISO 23936-2 and API 11D1 standard

## DESCRIPTION

In typical well completions, the injection or monitoring tubing string is isolated from the well casing by a production packer. This packer creates a mechanical anchor and a seal between the tubing and casing. The four main elastomers currently used in these packer element systems to seal between the tubing and the casing are Nitrile (NBR), hydrogenated Nitrile (HNBR), Aflas (FEPM), and Viton (FKM). These elastomers provide an excellent range of capabilities for most applications. However, in each case, there are trade-offs, which can introduce risks and costs to an operation.

For instance, NBR has balanced mechanical properties and performs well even at lower temperatures. However, its chemical resistance, particularly to corrosion inhibitors, is quite low. Aflas, on the other hand, is excellent for use in many inhibited brines, but has significant limitations in lower temperatures. Baker Hughes set out to develop a balanced element system that could be used confidently in a broader range of applications – carbon storage being a prime example.

	TEMPERATURE 40 °F (4 °C)	TEMPERATURE 350 °F (177 °C)	INHIBITED BRINE >200 °F (93.3 °C)	BROMIDE RESISTANCE	OIL-BASED MUD RESISTANCE	H <sub>2</sub> S RESISTANCE >10%	BALANCED MECHANICAL PROPERTIES	PRODUCED RESERVOIR FLUIDS
<b>MATERIALS</b>								
Aptum Seal	○	○	○	○	○	○	○	○
Nitrile (NBR)	○	X	X	X	○	X	○	X
Hydrogenated Nitrile (HNBR)	○	○	X	X	○	X	X	○
Viton (FKM)	○	○	X	X	○	○	○	X
Aflas (FEPM)	X	○	○	○	○	○	○	○

Due to excessive swelling, limit exposure to oil-based mud (OBM) during run-in

Due to excessive swelling, O-rings and packing elements require back-up mechanisms to reduce extrusion

Aptum™ seals are compatible with a range of industry standard corrosion inhibitors while still maintaining sealing capabilities in low downhole temperatures.

Carbon storage applications can create corrosive environments when CO<sub>2</sub> becomes mixed with water and other fluids in the wellbore. Completion equipment can often be exposed to hydrocarbons, formation water, CO<sub>2</sub> and a host of other corrosive fluids. A common and effective way of combating this corrosion is to treat the completion fluids with corrosion inhibitors. These corrosion inhibitors protect the metallic components of the completion including the casing, tubing, and packer body. However, they can also degrade the elastomer. As mentioned earlier, elastomers with excellent compatibility with inhibited fluids often have temperature limitations.

Many target formations for sequestration are shallow and have lower temperatures, making them difficult applications for elastomers such as Aflas. Add the potential for significant cooling during various phases of CO<sub>2</sub>-injection operations, and a new solution is needed. Aptum™ provides excellent performance at 4 °C (40 °F) yet maintains long-term compatibility with bromide- and chloride-inhibited brines.

When used as a part of the Premier™ removable production packer, Aptum™ seals enable a secure seal between the tubing and the casing, create a reliable mechanical anchor for the tubing string throughout extreme temperature and pressure changes, and is easily removed from the well for workover or plug and abandonment activities.



## HEAVY METAL™ SWARF-FREE SECTION MILLING BAKER HUGHES



### SUMMARY

Many of the world's most promising geological targets for large scale CO<sub>2</sub> storage exist in and above late-life and depleted hydrocarbon plays. Late-life fields often have many existing wells that penetrate the target storage geology and can pose seal integrity risks. Baker Hughes offers advanced plug and abandonment solutions to ensure that the integrity of aging infrastructure is not compromised for the life of the sequestration project. During plug and abandonment operations, it is sometimes required to remove a section of the casing and adjacent cement sheath to expose the formation. This process is called section milling. Section milling operations provide an effective downhole seal during plug and abandonment

by setting a cement plug directly across the geologic seal - removing metal tubulars and potentially failed cement. However, section milling operations can be challenging, which makes its large scale use less appealing. Additionally, conventional section milling requires specialized equipment to handle the cuttings or 'swarf' that are brought to surface during milling operations. HEAVY METAL™ swarf-free section milling system increases the efficiency while decreasing the cost and carbon footprint of section milling operations. By improving the performance and economics of section milling operations, wells can be plugged more effectively and with less long-term risk of seal integrity issues.

### BENEFITS

- Provides a robust rock-to-rock barrier
- Reduces cost and time associated with section milling
- Decreased health, safety & environment (HSE) risk for personnel on site
- Reduces requirements for rig capability, swarf handling, and other specialized equipment
- Eliminates the need for swarf cleaning, transport, and disposal

### DESCRIPTION

Section milling is a conventional method for casing removal during plug and abandonment (P&A) operations where annular well integrity is compromised or questioned. The removal of casing by milling a window provides full access to the virgin formation, enabling placement of a rock-to-rock barrier. Swarf is an unavoidable by-product of section milling, generating thousands of pounds of these sharp metal cuttings that have to be removed from the well. Retrieving and handling the swarf is a time-consuming and costly process that poses additional health, safety, and environmental (HSE) risks, and oftentimes operators will opt for less reliable options, such as perf-and-wash, just to avoid swarf.

Baker Hughes offers the HEAVY METAL™ swarf-free section milling service to provide a reliable solution without the negative side effects of swarf. It eliminates swarf to surface through a unique upwards milling process, depositing swarf deep in the rathole, while still enabling a secure rock-to-rock barrier. This unique service reduces time and costs in half, eliminating the need for swarf removal and the risks that swarf presents to people, equipment, and the environment. The bottomhole assembly (BHA) consists of multiple tools providing different functions to enable upwards section milling using normal right hand drill pipe connections without any rotation at surface. A torque isolator allows uninterrupted axial movement and continuously isolates reactive torque of the left-hand mud

### CONTACT

Gianluca Di Federico

Email: [gianluca.difederico@bakerhughes.com](mailto:gianluca.difederico@bakerhughes.com)

Web: [www.bakerhughes.com](http://www.bakerhughes.com)

motor, while milling upwards. The mud motor requires circulation from surface and provides downhole left-hand-rotation and torque to the section mill and auger.

The system's section mill features upward-facing knives that utilize METAL MUNCHER™ advanced milling technology (AMT) carbide cutting structures and allow upward milling and reaming in one run—even in long laterals. The section mill cuts through the casing at the bottom of the window, mills upwards to the desired distance, and then reliably retracts its knives at the top of the window.

The auger continuously transports any swarf created from the window to the bottom of the rathole, leaving it all in the well, while providing a window free of swarf. Because the swarf does not have to be circulated to surface, there is no need to change over to a high viscosity milling fluid, saving additional cost and logistics.

A Baker Hughes dedicated project management team can oversee the entire P&A project—from planning phase through final abandonment— all with a strong focus on safety and efficiency. With a single point of contact, customers achieve a simplified, streamlined process that helps reduce time and minimize risk.





### SUMMARY

Our mineralization technology has billions of hours of testing in nature, as we replicate the process where sea urchins build their shell and spikes through mineralization of CO<sub>2</sub> and calcium that are naturally found in seawater. Dr. Lidija Siller at the Newcastle University upon Tyne is a nano-scientist and the inventor of CAPTICO2's unique and patented mineralization technology. CAPTICO2 uses a catalyst to dramatically increase the speed and efficiency of CO<sub>2</sub> mineralization. CAPTICO2 has an exclusive worldwide license to commercialize this patent, covering all areas of use on any fossil burning source.

Carbon dioxide (CO<sub>2</sub>) mineralization is a process, which does not require CO<sub>2</sub> capture. This is because, there is already a significant amount of CO<sub>2</sub> present in brine or seawater. This CO<sub>2</sub> will be converted regardless of its concentration. CAPTICO2 has developed a highly cost-effective cryogenic capturing technology, which can capture CO<sub>2</sub> at a cost of EUR 15-20/t CO<sub>2</sub>. With the CAPTICO2 turnkey CCUS solution, the total cost of CO<sub>2</sub> capture and mineralization, including source supply and logistics for the end-product is between EUR 30 – 40/t CO<sub>2</sub>, and the best of all - we offer a solution for each step of the CCUS loop: Carbon Capture, Utilization and Storage.

### BENEFITS

The following highlights describe the benefits of the CAPTICO2 CCUS technologies:

- Proven, patented and certified CO<sub>2</sub> mineralisation technology applicable for all fossil-based emission sources
- High-speed and high conversion rate due to utilization of readily available catalyst in the mineralisation process
- Proven and patented cost-effective, health and environment-friendly CO<sub>2</sub> capture technology, by cooling the components in flue gas and separating CO<sub>2</sub> without the use of expensive and harmful amines
- Highly competitive investment and operational cost between EUR 30 - 40/t CO<sub>2</sub> captured and mineralized, which is half the cost of competing solutions
- Closed loop solution covering CO<sub>2</sub> capture to mineralisation, storage, and utilisation, whereas most competitors offer only CO<sub>2</sub> capture, leaving out solutions for transportation and storage
- Rapid technology development enables us to bring our technology to a commercial state by the end of 2022, offering full-scale compact and scalable 1.3 Mtpa CO<sub>2</sub> capture and conversion modules to customers worldwide

### DESCRIPTION

While studying marine biology at a nano-particle level, Dr. Siller discovered the natural process through which sea urchins quickly mineralize CO<sub>2</sub> to build their shell and spikes, using naturally available catalyst present in sea water. Building upon this discovery, Dr. Siller and her team at Newcastle University upon Tyne, successfully tested a laboratory-scale tubular reactor for hundreds of hours that mineralized CO<sub>2</sub> in only 60 seconds. CAPTICO2 holds a worldwide, exclusive license to commercialise the patented technology developed by the Newcastle University upon Tyne. In August 2020, CAPTICO2 successfully tested the CO<sub>2</sub> mineralization technology at a government owned waste-to-energy plant in Norway, in collaboration with "Det Norske Veritas", DNV, a renowned third-party certification company, upon which we received a Certificate of Feasibility. The cryogenic capture technology was developed by CAPTICO2 in collaboration with Sintef, a renowned Norwegian independent research institution. Cryogenic gas distillation has traditionally been known to require high energy consumption. By utilizing energy conserving principles from the oil and gas industry, and running extensive advanced process simulations, CAPTICO2 has been able to develop a cryogenic distillation process, which can separate 99% CO<sub>2</sub> from the flue gas at a cost of EUR 15-20/t CO<sub>2</sub>.

The traditional approach to CO<sub>2</sub> capture involves the utilization of amine-based absorption. There are several challenges with most amine-based technologies, such as the high cost of the amines, the harmful health impact from the toxic amines, and limitations on the lifetime of the amines. CAPTICO2's cryogenic capture is non-toxic, uses nitrogen and oxygen present in the flue gas as cooling medium to distil CO<sub>2</sub> from the flue gas. In combination with the CO<sub>2</sub> mineralization technology, CAPTICO2 can provide yet another step in the CCUS process, which is typically not offered by CO<sub>2</sub> capturing companies: conversion of captured and volatile CO<sub>2</sub> to a non-toxic, long-term storable and usable mineral, calcium carbonate, and thereby closing the loop for our customers.

In collaboration with Enea, the fourth largest Polish provider of electrical power, CAPTICO2 will certify our technologies to the European Union's definition of Technical Readiness Level (TRL) 7 in 2022, which is described as a system prototype demonstrated in operational environment.

A fully mobile project test rig with a capacity of 1,300 tonne CO<sub>2</sub> capture and mineralization per year will be installed at one of Enea's coal power plants in Poland for a period of 3 months, followed by a Front-End Engineering and Design (FEED) study for full-scale CCUS modules. At the end of 2022, we expect to be ready to offer the sale of our modules.

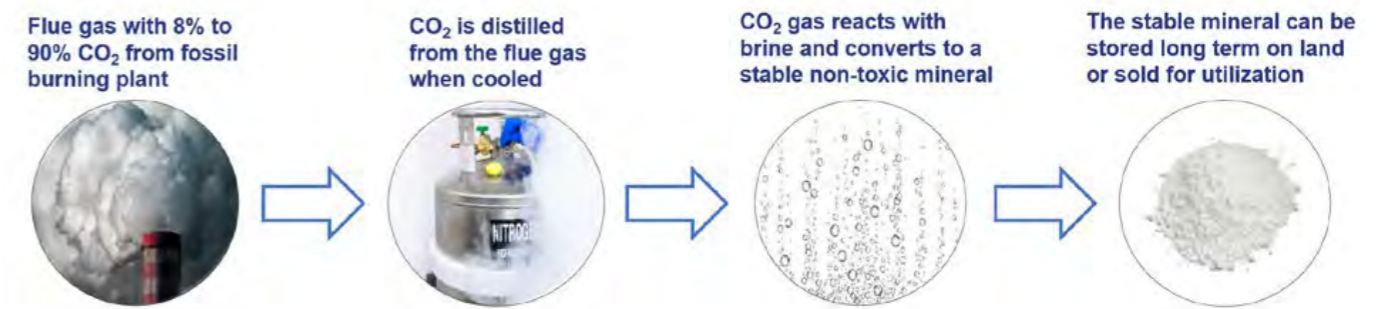





## SUMMARY

The Carbfix process captures CO<sub>2</sub> and turns it into stone underground in under two years through technology that imitates and accelerates natural processes, providing a permanent carbon storage solution. Carbfix is the world's first organisation dedicated to facilitating and implementing carbon capture and mineral storage (CCMS) worldwide. Robust research and innovation based on subsurface geochemical processes laid the foundation for injection of dissolved CO<sub>2</sub> into mafic and ultramafic formations for efficient mineralisation. To date, such approach is the safest and fastest carbon capture and storage (CCS) method applicable at industrial scale.

Carbfix can adapt its well-established technology to a range of point source emissions as well as direct air capture technologies with a portfolio of solutions. Where local conditions allow, mineral storage operations co-

located with the emission sources offer one of the most economic full-chain CCS in the world. Carbfix is also pioneering mineral storage in connection with direct air capture technologies (for example, Climeworks' Orca plant) as well as large scale hubs that can receive transported CO<sub>2</sub> (Coda Terminal). On top of the numerous ongoing projects, Carbfix offers consultancy services and carries out feasibility studies tailored to each project and facility. Factors such as flue gas composition, local geology and water availability determine whether on-site storage or transport to offsite storage facilities is the most feasible for customers wanting to permanently convert their CO<sub>2</sub> emissions to stone. Carbfix has carried out generic cost estimates and process simulations for selected industry sectors, providing assessments for footprint, water and energy requirements and associated CapEx and OpEx.

## BENEFITS

The Carbfix technology is:

- Built on firm scientific foundation and robust monitoring campaigns
- Safe. The risk of leakage is fully eliminated by dissolving CO<sub>2</sub> in water
- Cheaper than alternative solutions, has lower up-front capital costs and financial risks
- Environment-friendly. The process imitates and accelerates nature's way of storing CO<sub>2</sub> in rocks with no chemicals used other than water
- Permanent. Minerals are stable for thousands of years limiting the need for long-term monitoring
- Highly flexible with respect to capture technology used, injection strategy and up-scaling
- Dissolved CO<sub>2</sub> has less stringent requirements for pipe and casing material than pure CO<sub>2</sub>
- Able to provide added value through co-capture of other soluble industrial gases such as sulphur oxides, nitrogen oxides, hydrogen sulphide and fluorine
- Seeing higher levels of public acceptance than conventional CCS





## DESCRIPTION

Trees and vegetation are not the only form of carbon drawdown from the atmosphere. Vast quantities of carbon are naturally stored in rocks. Carbfix imitates and accelerates these natural processes, offering a permanent and safe carbon sink. The technology provides a complete carbon capture and injection solution, where CO<sub>2</sub> dissolved in water is injected into the subsurface where it reacts with favourable rock formations, such as basalts, to form solid carbonate minerals via natural processes. For the Carbfix technology to work, one needs to meet three requirements: suitable rocks, water, and a source of carbon dioxide.

Carbonated water is acidic. The more carbon you can pack into water, the more acidic the fluid will become. Carbfix's carbonated water reacts with rocks underground and releases available cations such as calcium, magnesium and iron into the water stream. Over time, these elements combine with the dissolved CO<sub>2</sub> and form carbonates, thus filling up the empty space within the rocks. The carbonates are stable for thousands of years and can therefore be considered permanently stored. The timescale of this process initially surprised scientists. In the CarbFix pilot project, it was determined by a suite of chemical and isotopic tracers that at least 95% of the injected CO<sub>2</sub> mineralised within two years, much faster than previously thought. Once the mineralisation process is confirmed, further monitoring is not required.

The injected carbonated water is denser than the surrounding water in the geological formation, and therefore, has the tendency to sink after it has been injected. This differs from more conventional methods of carbon capture and storage, which depend on cap rock to prevent possible leakage of gaseous CO<sub>2</sub> injected into deep formations that are overall not very reactive. Young basaltic rocks are highly fractured and porous such that water seeps easily through the interconnected cracks and empty spaces underground. It has been estimated that after injecting 100,000 tons of gas into the Hellisheiði basaltic reservoir only 0.05% of the storage space was filled with solid minerals. The global storage potential of such favourable formations (Carbfix atlas)<sup>1</sup> is greater than the emissions of the burning of all fossil fuels on Earth. It is estimated that Europe could theoretically store at least 4,000 billion tons of CO<sub>2</sub> in rocks, while the United States could store at least 7,500 billion tons.

The Carbfix technology requires significant amounts of water, which is co-injected into the subsurface with the CO<sub>2</sub>. To address this, Carbfix has already developed the scientific basis for using seawater, a near-unlimited resource, to dissolve CO<sub>2</sub> prior to injection, thus expanding the applicability of the technology to water scarce regions, coastal and offshore areas. A field site demonstration of mineral storage using seawater will take place in SW-Iceland in 2022 (CO<sub>2</sub>-Seastone project).<sup>2</sup>

Carbfix operations only use minimal above-surface infrastructure, whose footprint is further reduced by innovative approaches such as using multi-well well-pads where several injection wells are drilled from the well-pad.

Carbfix is being deployed and further validated in numerous ongoing projects. The now routine CCS operations taking place at the Hellisheiði power plant (Iceland) capture the plant emissions (CO<sub>2</sub> and H<sub>2</sub>S) through a simple on-site single-stage water scrubbing process, and then injecting the mixture into the basaltic bedrock where it forms solid carbonate and sulphide minerals. With the help of EU Innovation Fund, emissions from the power plant will be reduced to near-zero by 2025 (Silverstone project).<sup>3</sup> Cost of on-site CCS operations at Hellisheiði is US \$24.8/ton – much lower than the recent average price of EU Emission Trading System allowances. By applying the Carbfix process also to capture and mineralise H<sub>2</sub>S along with CO<sub>2</sub>, instead of conventional sulphur removal methods, significant economic benefits have been achieved.

Further developments of the Carbfix technology at the Hellisheiði power plant include the Orca project,<sup>4</sup> which builds upon the collaboration with a Swiss tech company specialized in direct air capture (DAC). Project Orca has the capacity of capturing 0.004 Mtpa CO<sub>2</sub>, which is being injected by Carbfix into nearby basaltic formations and permanently turned into stone.

An even bigger Carbfix upscaling towards tackling the global CO<sub>2</sub> emissions is represented by the Coda Terminal,<sup>5</sup> a scalable cross-border carbon transport and mineral storage hub in Iceland. Carbon dioxide (CO<sub>2</sub>) is captured at industrial sites in North Europe and shipped to the Terminal where it is unloaded into onshore tanks and subsequently pumped into a network of nearby injection for permanent storage. The target capacity of the Coda Terminal is to reach 3 Mtpa CO<sub>2</sub> stored in the basaltic bedrock by 2030-2034.

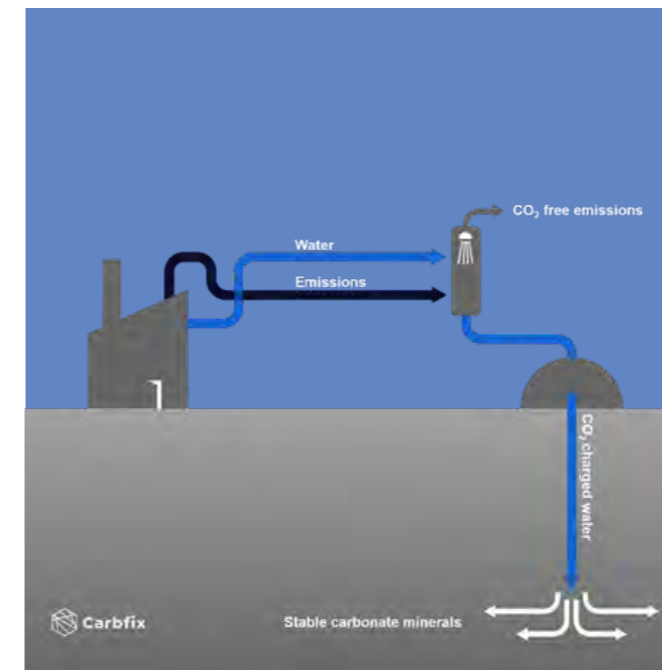
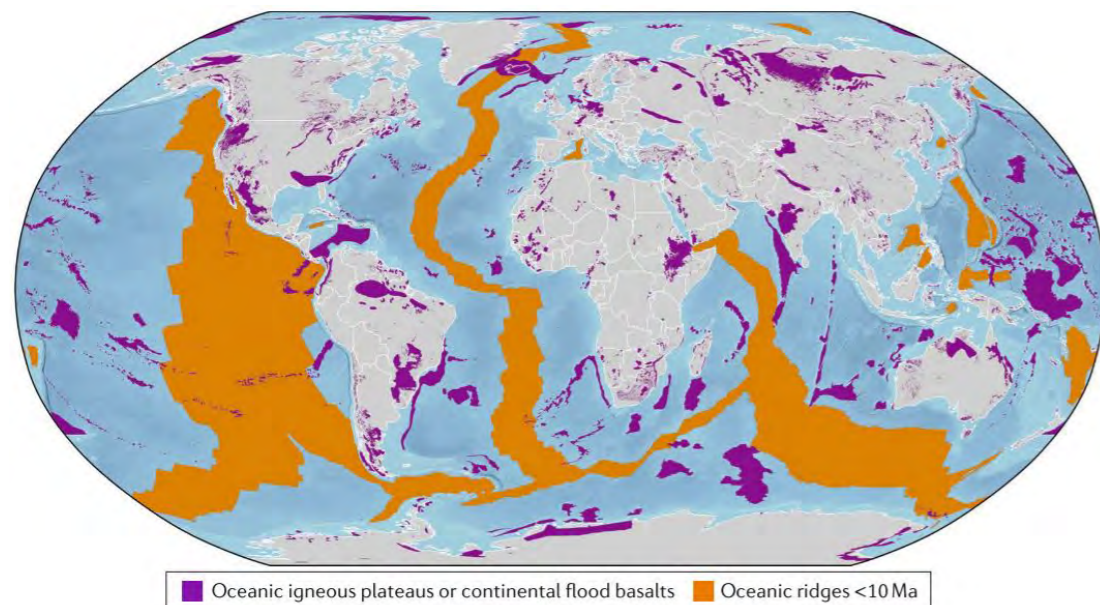

<sup>1</sup> <https://www.carbfix.com/atlas>

<sup>2</sup> <https://www.carbfix.com/CO2-seastone>

<sup>3</sup> <https://www.carbfix.com/Silverstone>

<sup>4</sup> <https://www.carbfix.com/currentoperations>

<sup>5</sup> <https://www.carbfix.com/codaterminal>



# CARBON CAPTURE, UTILIZATION AND STORAGE CHEVRON



CONTACT

Brian Chase  
Email: [newenergies@chevron.com](mailto:newenergies@chevron.com)  
Web: [www.chevron.com](http://www.chevron.com)



## SUMMARY

At Chevron, we believe the future of energy is lower carbon. Reducing the carbon intensity of the energy that people rely on is a tremendous opportunity to advance the global net-zero ambitions of the Paris Agreement. We're looking to the future with confidence by applying more than 140 years of experience to help meet the expanding energy needs of a growing world, while accelerating progress towards a lower carbon future.

Our energy transition approach is straightforward: we are lowering the carbon intensity of our operations and growing lower carbon businesses. We formed Chevron

New Energies (CNE) in August 2021 to advance lower carbon solutions, and scale businesses in hydrogen, carbon capture, utilization, and storage, offsets and emerging lower carbon opportunities. These businesses will target sectors of the economy where emissions are harder-to-abate or that cannot be easily electrified, such as heavy-duty transportation, refining and petrochemicals, steel, and power generation.

Chevron New Energies aims to provide integrated, lower carbon solutions across the value chain by leveraging our capabilities, assets, and customer relationships.

## BENEFITS

- Chevron is well-placed to be a CCUS leader building upon our capabilities, assets, and customer relationships.
- We bring decades of operational experience and a proven track record of carbon capture projects.
- We are one of a few companies with the ability to execute across the CCUS value chain and scale CCUS.
- Since 2018, we've committed about \$500 million to lower-carbon investments to help bring innovation to scale.
- Chevron New Energies aims to provide integrated, lower carbon solutions across the value chain for partners and customers, and is working to help lower the carbon intensity of our operations.

## DESCRIPTION

### Why we need CCUS at scale

Carbon capture, utilization and storage (CCUS) is a critical enabler of global net-zero, and our CCUS targets reflect its importance. We see CCUS as an enabler in reducing the carbon intensity of our existing assets and as a business opportunity to provide emissions reduction solutions for partners and customers. We are targeting 25 million of tonnes per annum in equity storage by the end of this decade.

Chevron is actively evaluating multiple locations to implement CCUS solutions that would support our internal efforts to lower the carbon intensity of our operations, and also grow a lower carbon business. By aggregating emissions, we see a future in the development of CO<sub>2</sub> sequestration hubs in underground storage sites where CO<sub>2</sub> can be stored permanently. We have oil & gas operations across the world and our refinery network

spans the United States and Asia Pacific, providing a variety of high-value products to the global marketplace. Neighbouring industrial plants and third-party emitters can be enrolled as potential partners and customers as hub concepts and projects are developed.

We are also focused on investing in innovative projects across the CCUS value chain to reduce costs, develop new ways to capture, use, and sequester carbon, with the goal of scaling these solutions.

Chevron has committed \$100 million to the Oil & Gas Climate Initiative, bringing our lower carbon investments through our venture organization since 2018 to about \$500 million. These investments target cutting edge technologies, bringing early insights through pilot programs – often utilizing Chevron's existing assets. Learn more by visiting <https://www.chevron.com/technology/technology-ventures>

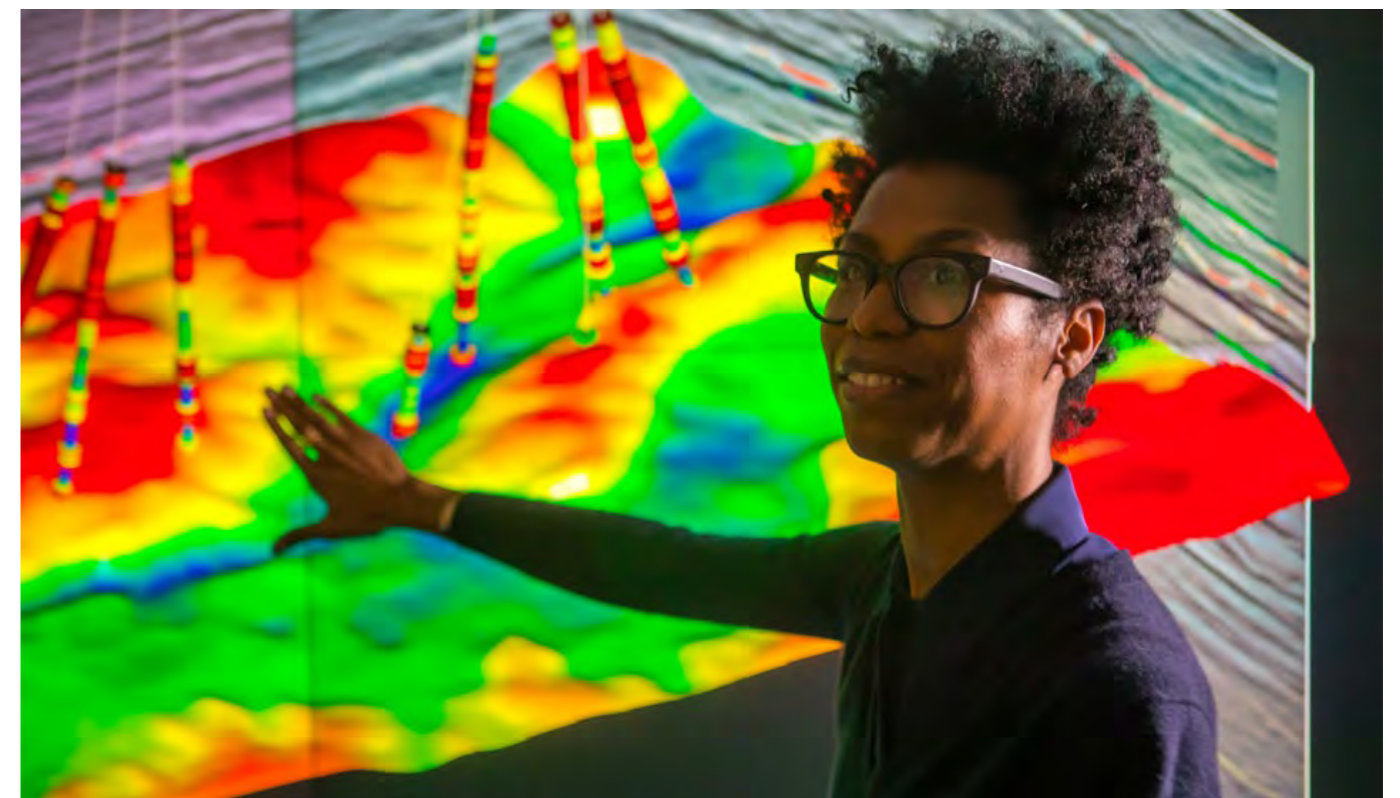



### Chevron CCUS project spotlights

Chevron brings decades of operational experience through our large-scale deployment of CO<sub>2</sub> injection into oil formations for enhanced oil recovery in the United States over approximately the last 40 years. We have safely operated a CO<sub>2</sub> pipeline in Colorado for 35 years. This experience is coupled with our capabilities in drilling, geology, injection, pipeline operations, monitoring and managing pressure in wells, and our ability to successfully bring together diverse stakeholders across the value chain.

We have a proven track record of carbon capture projects that have been focused on lowering the carbon intensity of our existing assets. For example, our Gorgon Project in Australia is one of the largest sequestration projects in the world with the capacity to store up to 4 million of tonnes per annum CO<sub>2</sub>. The Gorgon carbon capture and storage project involves the design, construction, and operation of facilities to inject and store CO<sub>2</sub> into a deep reservoir unit, known as the Dupuy Formation, more than two kilometres beneath the Barrow Island — providing us with key operational experience.

Chevron is committed to leveraging its capabilities, assets, and customer relationships to lead the way in carbon capture, transportation, storage, monitoring, and utilization. We are investing in several technologies related to CCUS and implementing pilots to demonstrate more efficient and cost-effective capture solutions for emissions streams with various CO<sub>2</sub> concentrations.

We are advancing a project awarded from the U.S. Department of Energy (project #DE-FE0031944) to pilot technology that captures CO<sub>2</sub> from post-combustion gas at our Kern River Carbon Capture site in San Joaquin Valley, California. In collaboration with Svante and the National Energy Technology Laboratory, we are planning to test Svante's innovative new technology to reduce CO<sub>2</sub> capture costs.

We recently completed front-end engineering design (FEED) on concentrating equipment for a commercial-scale pilot in the San Joaquin Valley, California to capture CO<sub>2</sub> from a cogeneration plant's gas turbine. The project combines two technologies, CarbonPoint Solutions\* Semi-Closed Cycle CO<sub>2</sub> Concentration Technology and Carbon Clean Solutions Limited's Advanced Rotating Packed Bed Solvent Capture Technology. This opportunity could capture over 200 tonnes per day of CO<sub>2</sub>.

Chevron and Carbon Clean aim to develop a carbon capture pilot for Carbon Clean's CycloneCC™ technology by separating CO<sub>2</sub> from a co-generation plant's exhaust at our facility in San Joaquin Valley, California. Carbon Clean's patented technology is expected to reduce the costs and physical footprint required for carbon capture compared with many existing techniques.

CCUS offers opportunities to unlock markets for lower carbon products as compared to conventional products, such as blue hydrogen and biomass power to meet growing energy demands while creating a lower carbon economy. At our Richmond Refinery, we're exploring the development of a regional CCUS hub that could enable blue hydrogen.

### Delivering Lower Carbon Solutions

Our capabilities, assets, and customer relationships will serve as a platform for rapid growth in the years to come. Our existing assets span the value chain and are in areas where we can facilitate demand based on cost-competitive supply combined with appropriate policy support. We have strong relationships with key customers and partners, which will be critical in developing economic projects that can scale quickly across a complex value chain.

Innovation, technology, and policy will be key drivers of change. We begin with a portfolio of existing assets and decades of experience as a strong foundation for future growth. We've successfully managed complex, joint ventures all over the world. We have deep technical expertise inside the Company and a long history of advancing and adopting external innovation. We have strong commercial capabilities and experience managing rapidly changing businesses. Managing diverse stakeholder and government interests is something we do every day. Chevron's credibility and reputation make us the partner of choice, bringing access to new opportunities.



Gorgon is one of the largest sequestration projects in the world.

\* Acquired by Caterpillar in 2021





## SUMMARY

Japan CCS Co., Ltd. (JCCS) was founded in May 2008 when a group of major companies with expertise in CCS-related fields, including electric power, petroleum, oil development, and plant engineering, joined forces to answer the Japanese government's call for development of CCS technology.

JCCS has been conducting the Tomakomai CCS Demonstration Project, Japan's first full-chain CCS demonstration project in Tomakomai City, Hokkaido Prefecture, Japan since JFY2012 (JFY: Japanese fiscal year from April to March). The project was commissioned to JCCS by the Ministry of Economy, Trade and Industry (METI) between JFY2012 and 2017, and from JFY2018 by New Energy and Industrial Technology Development Organization (NEDO) with subsidies from METI.

Prior to the selection of Tomakomai as the demonstration project site, site surveys and a site selection process were conducted from JFY2008 to 2011. At first, there were 115 candidate locations. After an evaluation of existing data and site surveys, Tomakomai was finally selected due to technical reasons including the confirmation of good reservoirs and overlying cap rocks, and that no active faults were found at the Tomakomai site. In addition, a decisive factor was that the local community, in particular the Tomakomai city mayor, supported the project. Furthermore, the Tomakomai site was located in an oil exploration area where a leading shareholder of JCCS had acquired a lot of geological data. This made it possible to characterize the site within a limited period. The original project schedule

comprised a four-year construction, three-year CO<sub>2</sub> injection and two-year post injection monitoring period. Aiming to establish CCS technology for practical use by around 2020, the main objectives and tasks of the project are as follows:

- Demonstrate a full-chain CCS system from capture to storage
- Demonstrate that the CCS system is safe and reliable
- Remove concerns about earthquakes by the data collected by establishing:
  - No influence by natural earthquakes on CO<sub>2</sub> stored
  - No perceptible earth tremors induced by CO<sub>2</sub> injection
- Disclose project information and data and enhance understanding of CCS by local residents
- Acquire operational technology as well as strive towards practical implementation.

As Japan is an earthquake-prone country, removing concerns regarding earthquakes is vital.

The actual CO<sub>2</sub> injection period was three years and eight months. The target of 300,000 tonnes of CO<sub>2</sub> injection was achieved in November 2019. Monitoring operations are being continued.

JCCS is able to share the knowledge and experience acquired from the Tomakomai Project.

## BENEFITS

JCCS can share the following knowledge and experience acquired from the Tomakomai Project.

- Capture and compression technologies (excluding inherent know-how belonging to the process licensor)
- Injection and monitoring technologies
- Public outreach experiences

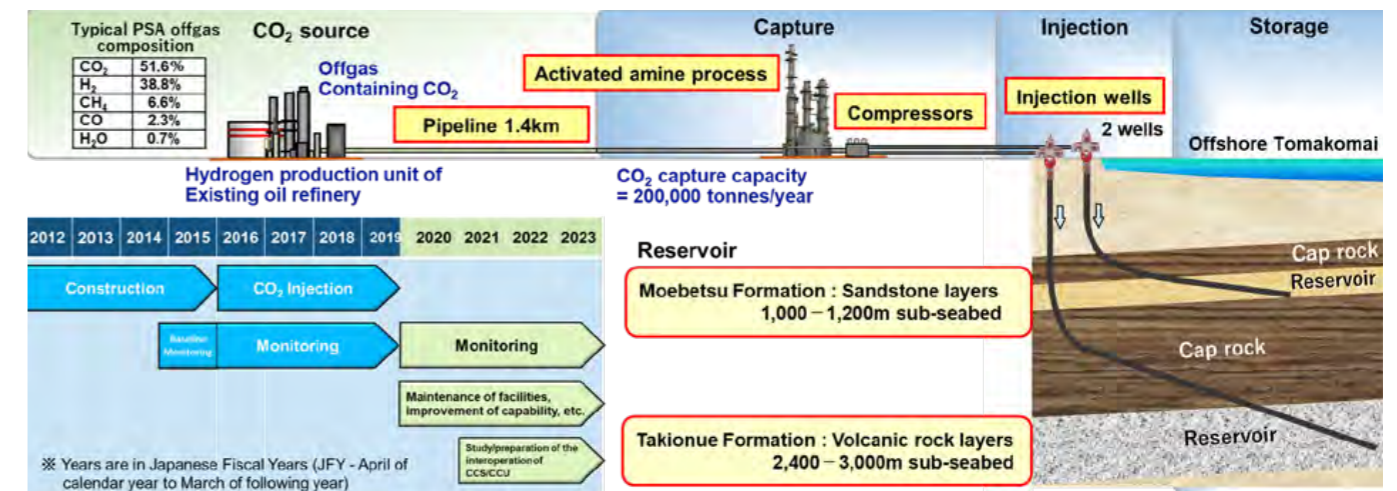
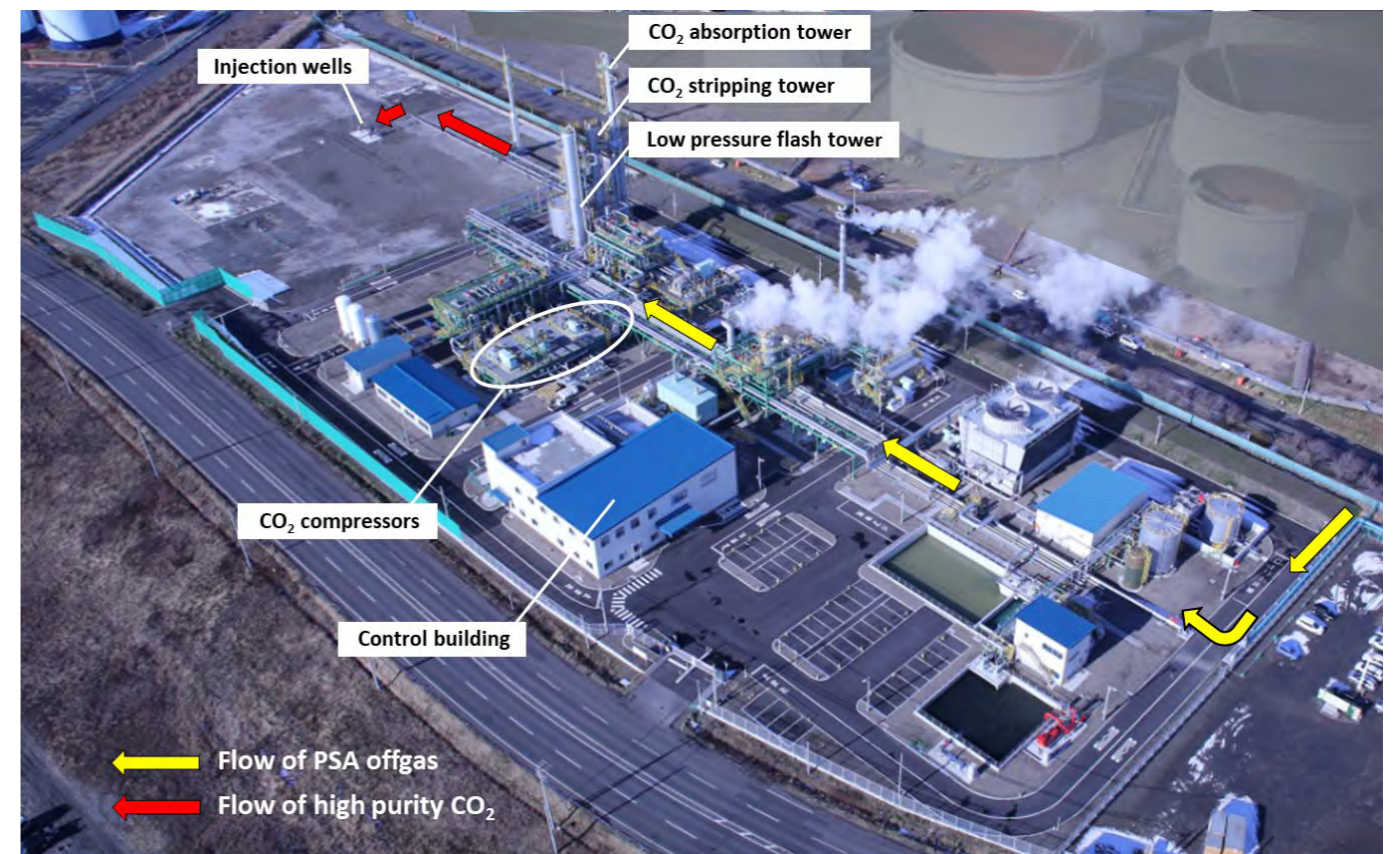



DESCRIPTION

JCCS can share the knowledge and experience acquired from the Tomakomai project as described below.

1. Overview of the Tomakomai Project

The Tomakomai CCS Demonstration Project is an offshore CCS project in Japan. The CO<sub>2</sub> source is offgas from an HPU (Hydrogen Production Unit) of an oil refinery located in the coastal area of the Tomakomai Port. Carbon dioxide (CO<sub>2</sub>) captured by an activated amine process is compressed and injected by two highly deviated injection wells drilled from an onshore site targeting two offshore reservoirs.

2. Key Results of Tomakomai Project

2.1 CO<sub>2</sub> capture

The CO<sub>2</sub> capture process used in the Tomakomai project is a commercially proven amine scrubbing process (OASE<sup>®</sup> by BASF), and the capture facility comprises of a two-stage CO<sub>2</sub> absorption tower, a CO<sub>2</sub> stripping tower and a Low-Pressure Flash Tower (LPFT), as shown in Fig. 1. The maximum CO<sub>2</sub> capture rate is 25.3 tonnes per hour.

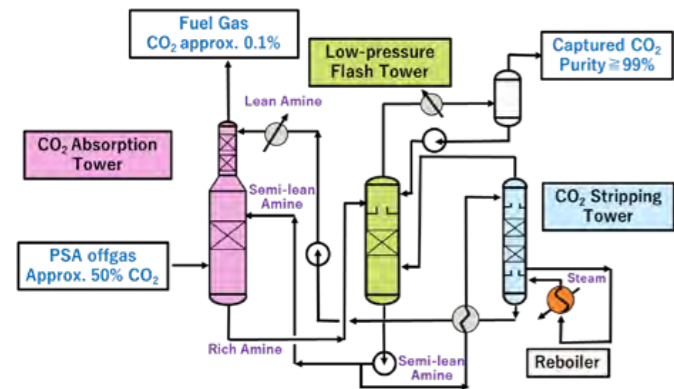

Figure 1. Two-stage absorption process

The two-stage absorption system results in a significant reduction of amine reboiler heat consumption in the CO<sub>2</sub> stripping tower as only a small amount of semi-lean amine needs to be sent to the CO<sub>2</sub> stripping tower. The reboiler heat consumption was measured as approximately 0.9 GJ/t CO<sub>2</sub> or less, which is a significantly lower energy consumption than that of a conventional one-stage absorption system. The purity of the captured CO<sub>2</sub> was greater than 99% (dry basis) at the top of the LPFT.

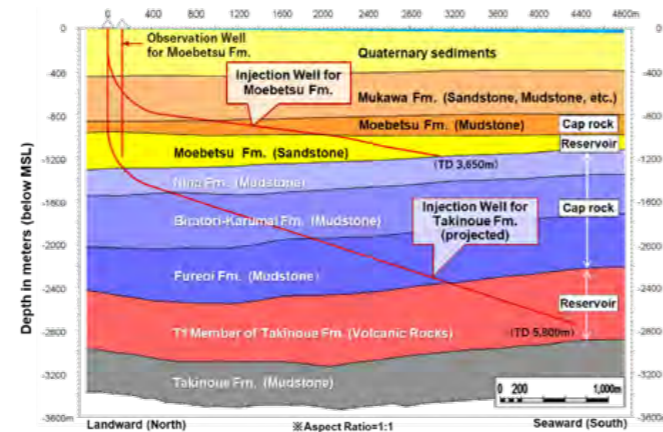

Figure 2. Schematic geological section

2.2 CO<sub>2</sub> injection and monitoring

A schematic geological section is shown in Fig. 2 with profiles of the deviated injection wells. The Tomakomai project targets two independent reservoirs of different depths and different lithofacies; the Lower Quaternary Moebetsu formation at about 1,000 to 1,200 m in depth and 3 km off the coastline, and the volcanic and volcanoclastic layers of the Miocene Takinoue formation at about 2,400 to 3,000 m in depth and 4 km offshore.

Onshore monitoring facilities consisted of a seismic station and three observation wells with pressure and temperature sensors and seismic sensors.

Offshore facilities consisted of an OBC (ocean bottom cable) with 72 seismic sensors and four OBSs (ocean bottom seismometers).

The facilities were deployed as shown in Fig. 3 and started operation on February 1, 2015, thirteen months before the start of CO<sub>2</sub> injection. CO<sub>2</sub> injection into the Moebetsu formation began on April 6, 2016 and was terminated with the cumulative amount at 300,012 tonnes on November 22, 2019. Carbon dioxide (CO<sub>2</sub>) injections into the Takinoue Formation were conducted from February 6 to February 23, 2018, and from July 31 to September 1, 2018. The injectivity of the Takinoue formation was much lower than expected, and therefore, the cumulative injection of CO<sub>2</sub> was 98 tonnes. To date, no seismicity attributable to CO<sub>2</sub> injection has been detected in the vicinity of the reservoirs. Seismic surveys at cumulative CO<sub>2</sub> injection of approx. 65,000, 207,000 and 300,000 tonnes into the Moebetsu Formation detected anomalies, indicating evolution of the CO<sub>2</sub> plume. Seasonal marine environmental surveys have detected no indications of seepage of the injected CO<sub>2</sub>.

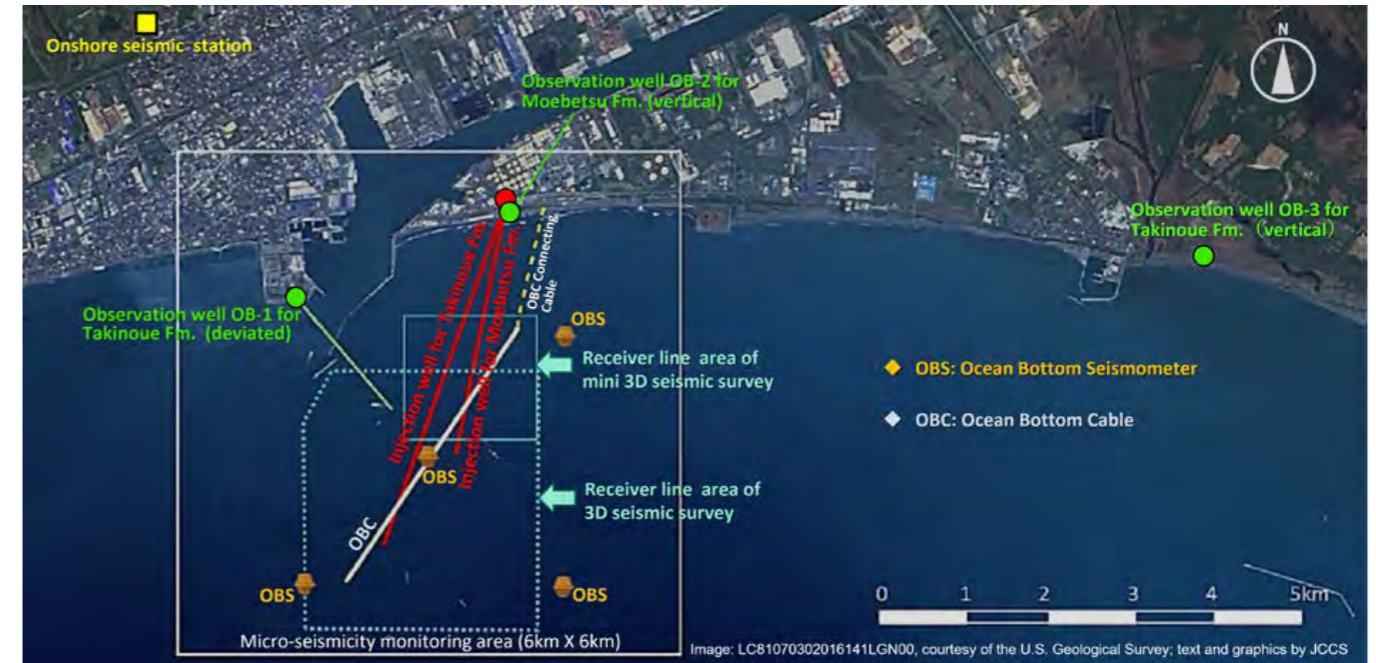

Figure 3. Layout of monitoring facilities

3. Public outreach activities

As the project is being conducted close to the centre of Tomakomai, a large industrial city including active fishing with a population of approximately 170,000, securing the trust of the local community through sustained communication, in particular with the local government and fishery cooperative, has been an important step in achieving the smooth delivery of the project. A key factor was the strong support of the city mayor and the local government, which formed the Tomakomai CCS Promotion Association in April 2010 that was chaired by the mayor of Tomakomai

and comprised of all the major local industries including the fishery cooperatives.

JCCS also places emphasis on removing concerns regarding earthquakes and securing trust in the safety of Japan's CCS technology through various public outreach activities such as forums for local residents, panel exhibitions, exhibits at environmental conferences, site tours, lectures, and experiment classes for schoolchildren. We have also maintained an information disclosure system in the city hall of Tomakomai (Fig. 4).



Figure 4. Public outreach activities





**LINDE'S TECHNOLOGY AND OPERATIONAL CAPABILITIES SUPPORT THE SWIFT ACHIEVEMENT OF DECARBONIZATION TARGETS AS WELL AS CO<sub>2</sub> UTILISATION CONCEPTS**

Linde has been developing and optimizing gas processing, separation and liquefaction technologies for more than 100 years. Through trusted, lasting business relationships, the company collaborates closely with its customers all over the world to develop tailored solutions that maximize plant lifecycle productivity, efficiency and service life. Its Engineering business delivers high-quality gas processing solutions to support customer expansion, efficiency improvements and emissions reductions. The Gases business is experienced in plant operations and in CO<sub>2</sub> transportation and handling.

The company offers a rich technology portfolio to help industry decarbonize processes and assets: The portfolio includes advanced technologies for harnessing renewable energies, for avoiding, reducing or capturing CO<sub>2</sub> emissions. Moreover, Linde's offerings cover purification, compression, liquefaction, storage, distribution and use of CO<sub>2</sub>.

In addition, Linde covers every step in the hydrogen value chain from production, processing, distribution and storage to applications. Services and digital innovations complement its decarbonization offering.

**TECHNOLOGIES FOR A LARGE VARIETY OF CARBON INTENSITIES AND SOURCES**

In essence, decarbonization is about reducing the carbon footprint of processes and products. For this, Linde provides a portfolio of technologies and services along the whole CO<sub>2</sub> value chain. When deciding which solution to select, the company's engineers first verify which CO<sub>2</sub> concentrations need to be addressed – low, medium and

high (Figure 1). Linde provides solutions for many different CO<sub>2</sub> emitting industries.

The technologies are further divided into their suitability for the CO<sub>2</sub> source, whether it be flue gas, natural gas, syngas or tailgas.

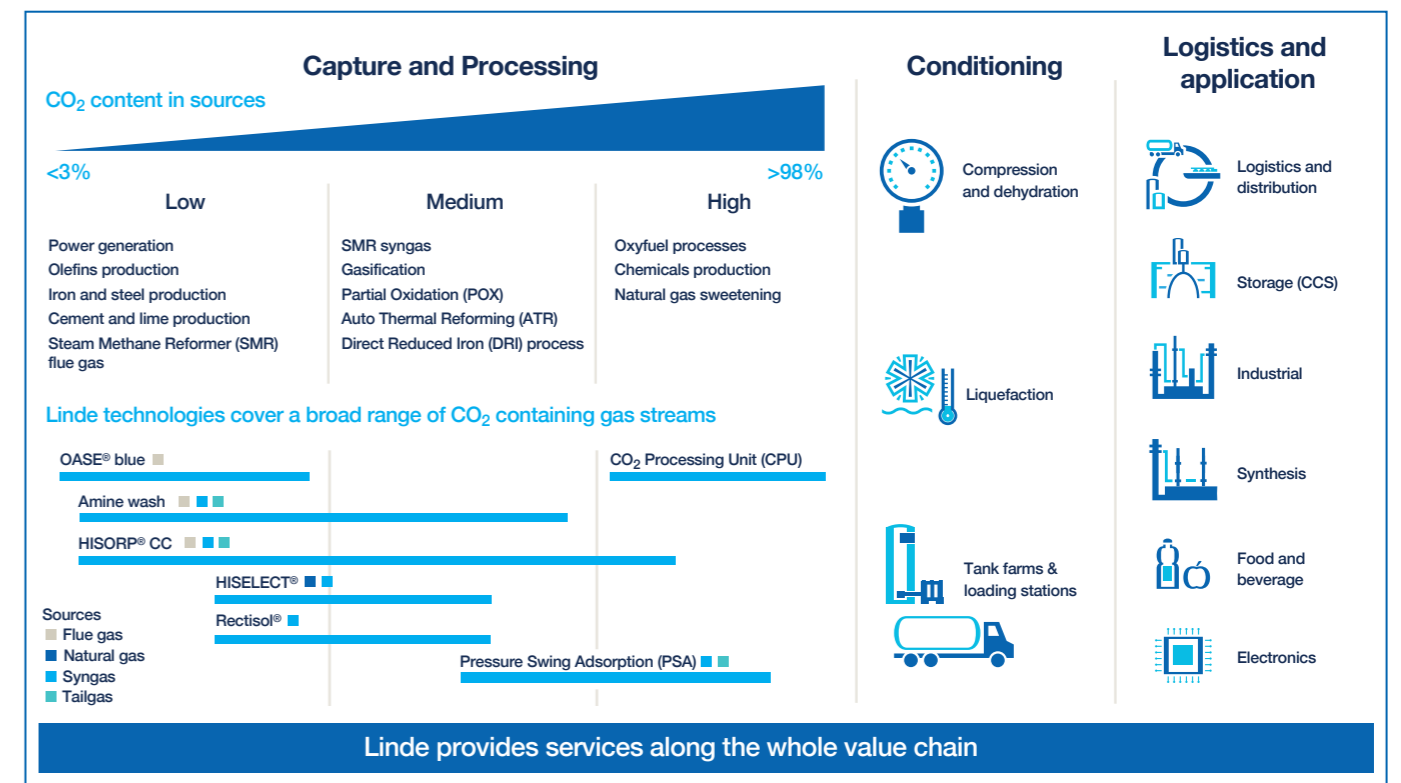

Figure 1: Overview of Linde's technology portfolio along the CO<sub>2</sub> value chain

The CO<sub>2</sub> technology portfolio is complemented with compression and dehydration plants as well as liquefaction plants and CO<sub>2</sub> tank farms with loading stations for trailers, trains and ships.

Linde also offers logistics and distribution solutions as well as plant and operator services among others for carbon storage and the industrial, synthesis, food & beverage and electronics sectors. Linde operates approximately 1,000 plants worldwide, providing a variety of services such as

- On-site gas production
- Investment, assembly & start up

- Operation & maintenance
- Backup system & logistics
- Remote Operations Centres
- Plant turnarounds

Further information on Linde's decarbonization and carbon management portfolio: Linde CO<sub>2</sub> Management Solutions (<https://www.engineering.linde.com/CO2>).

In the following key technologies are described.



FOR GAS STREAMS WITH LOW CO<sub>2</sub> CONTENT

OASE® blue technology for Post-Combustion CO<sub>2</sub> Capture (PCC)

Post Combustion CO<sub>2</sub> Capture (PCC) is a mature option to capture CO<sub>2</sub> from flue gas streams and thus ensures compliance with increasingly strict emissions thresholds. With the OASE® blue technology, CO<sub>2</sub> is removed from the flue gas through chemical scrubbing with an aqueous amine-based solvent (Figure 2). It can be implemented downstream of existing assets without interfering with upstream processes. For new assets, advanced plant integration concepts and optimized total costs of ownership can be accomplished.

The optimal design of turnkey facilities using OASE® blue technology has been jointly developed by BASF and Linde. It leverages BASF's capabilities in high-performance gas treatment technologies and Linde's strength and proven track record in design and delivery of turn-key industrial plants. This results in optimal interplay of solvent, process design, equipment and plant integration.

The technology can be applied to flue gases from various sources such as different types of power plants, gas motors, steam generators, cement plants and furnaces, just to name a few. It easily covers a spectrum from 3 to 25 vol% CO<sub>2</sub> content in the flue gas. The technology allows for CO<sub>2</sub> capture rates higher than 95% and generates

a CO<sub>2</sub> product purity of 99.9 vol% (dry). This purity is in compliance with the CO<sub>2</sub> product specification in most cases. Therefore, a further purification step may not be necessary.

This high-performance CO<sub>2</sub> capture technology in combination with our solid track record in large-scale gas treatment plants ensures low risk in EPC projects.

Highlights

- Compact footprint
- High CO<sub>2</sub> capture rate even at low CO<sub>2</sub> concentrations
- 20% lower energy consumption and 20% lower circulation rate compared to MEA solution
- Low solvent degradation rate even at elevated oxygen content in flue gas, and therefore, low solvent consumption rate
- Different options for energy and heat integration
- Unique emissions control technology for minimum environmental impact
- > 500 OASE® gas treatment plants in operation for different applications
- > 65,000 hours of operational experience with OASE® blue
- Reference plants in Germany and USA

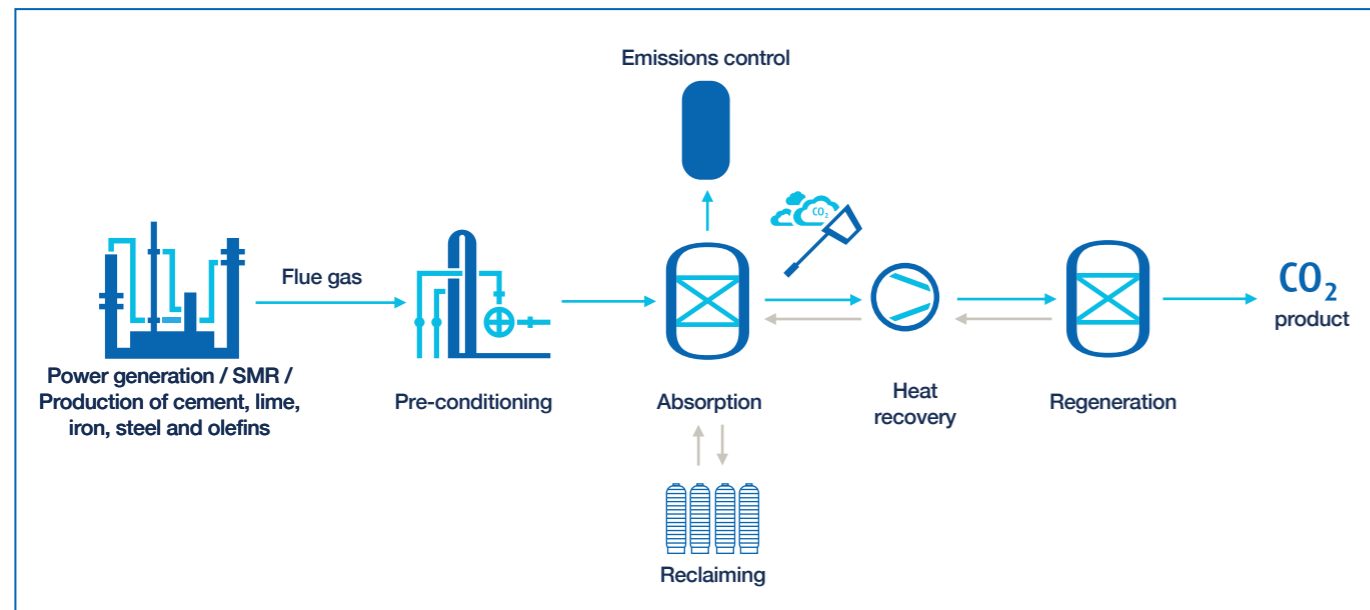

Figure 2: OASE® blue Post-Combustion CO<sub>2</sub> Capture (PCC) process  
<sup>1</sup> OASE® is a registered trademark of BASF SE

FOR GAS STREAMS WITH LOW TO MEDIUM CO<sub>2</sub> CONTENT

Amine wash

Amine wash processes are the standard for CO<sub>2</sub> removal from Steam Methane Reforming (SMR) based hydrogen, syngas and ammonia plants. CO<sub>2</sub> capture from syngas (Figure 3) is a proven technology. It achieves a CO<sub>2</sub> recovery rate of 99.9%. Further advantages include a low investment and favourable operating costs. Amine wash units can be installed in various areas of a plant, from low- to high-pressure applications. They are also suitable for advanced CO<sub>2</sub> removal as well as simultaneous removal of CO<sub>2</sub> and sulphur. Amine wash units can also be combined

with other Linde technologies, such as with the Linde Ammonia Concept (LAC™) or with cryogenic processes for carbon monoxide production.

Highlights

- State-of-the-art process
- Compact design
- Favourable design for low-pressure and high-pressure applications
- Compatible for CO<sub>2</sub> removal and/or sulphur removal

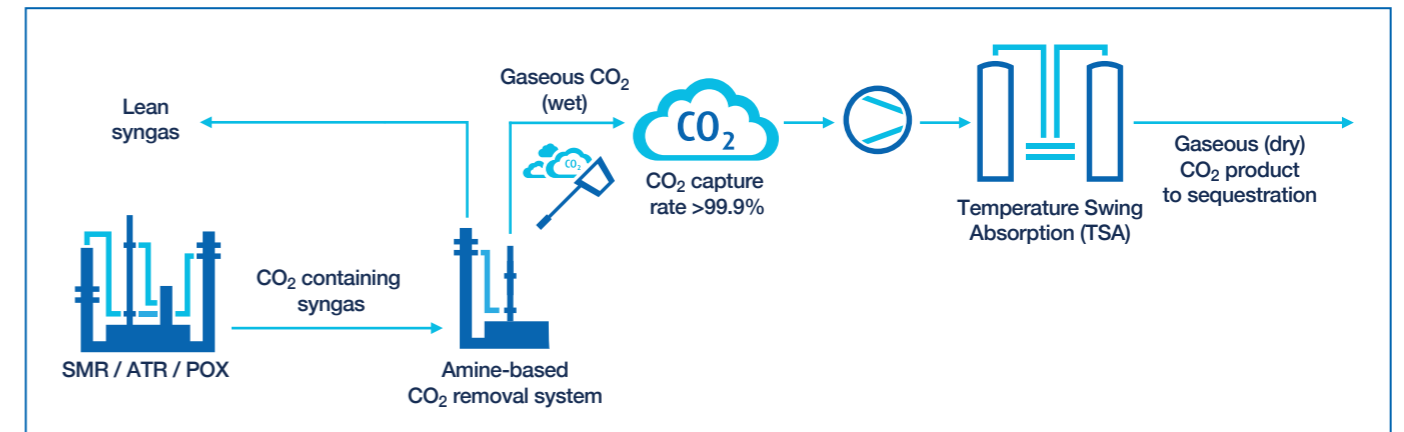

Figure 3: Amine wash-based CO<sub>2</sub> capture process from syngas





**HISORP® CC**

The adsorption-based HISORP® CC technology targets the reduction of the carbon footprint of hydrogen production plants (both for new-built and retrofit), such as SMR, autothermal reforming (ATR), partial oxidation (POX), and gasification (Figure 4). To produce blue hydrogen, it can be applied for CO<sub>2</sub> capture in the syngas or the hydrogen PSA tailgas route of existing SMRs and ATRs. A further use case is for Post Combustion CO<sub>2</sub> Capture (PCC) from the flue gases of SMRs and power plants. The technology achieves CO<sub>2</sub> capture rates of up to 99% from the particular gas stream and greater than 95% of the overall plant. HISORP® CC is flexible in regard to scale (covering all relevant industrial sizes), CO<sub>2</sub> feed concentration, the state in which the CO<sub>2</sub> should be exported (in gaseous, liquid or supercritical form) and all product purities (e.g. industrial grade or high purity beverage grade).

In addition, HISORP® CC can be applied to other industries where CO<sub>2</sub> emissions are hard to abate, such as steel and cement, or for coal-burning power plants.

**Highlights**

- No steam required for regeneration (therefore, no additional CO<sub>2</sub> generation), and no solvent is applied
- No solvent management required
- No extra cost for solvent makeup and handling
- Environmentally benign when powered with renewable electricity
- No hydrogen losses when applied for CO<sub>2</sub> capture from syngas or tailgas
- Low CapEx and OpEx

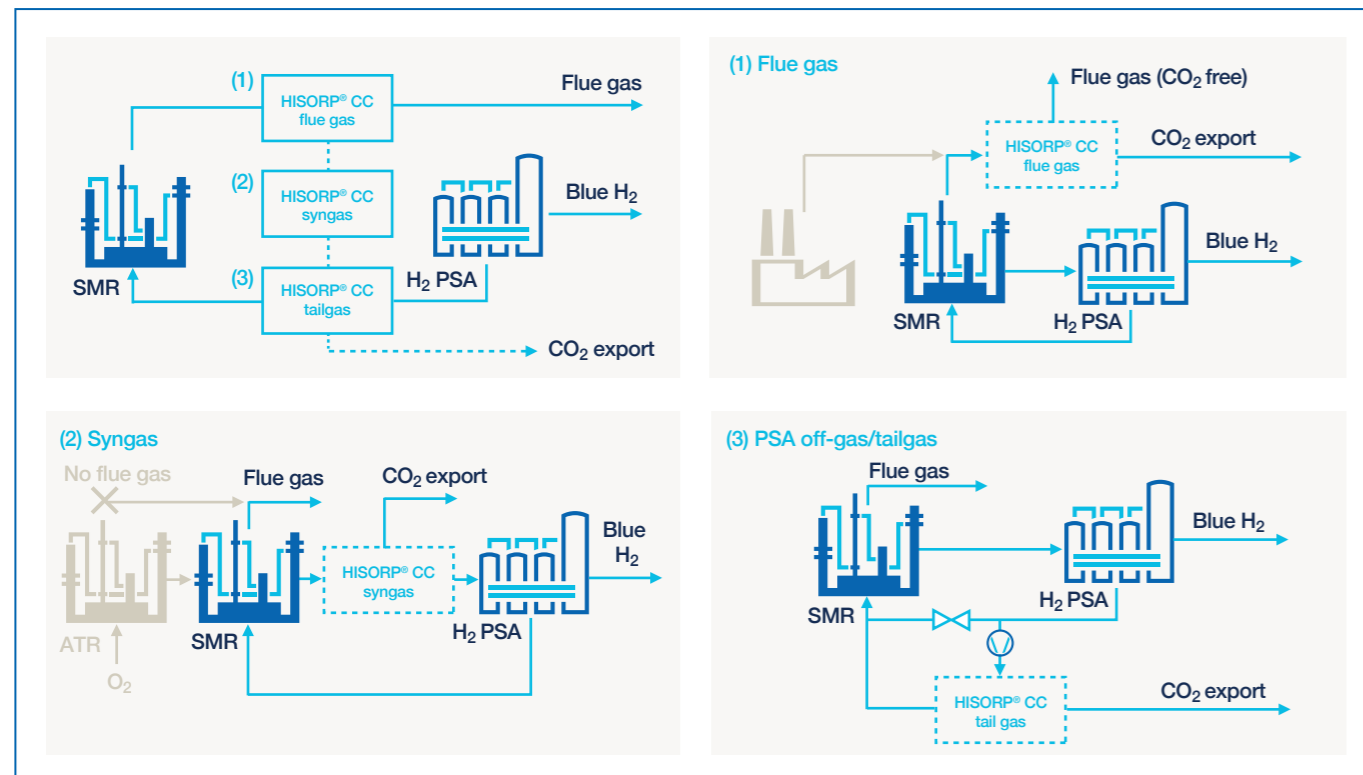

Figure 4: Typical adsorption-based HISORP® CC process for capturing CO<sub>2</sub> from flue gas (top right), syngas (bottom left), and tailgas (bottom right).

**HISELECT® powered by Evonik membranes**

The HISELECT® membrane was originally developed with a focus on natural gas and process gas industries. For natural gas resources with sour and acid fractions, membranes are an excellent alternative to conventional amine wash systems for acid gas removal. Driven by partial pressure difference, the HISELECT® membrane works like a semi-permeable barrier and separates the feed gas into a low-pressure permeate, rich in the gas to be removed or recovered (such as CO<sub>2</sub>) and a high-pressure retentate with a low content of these components. A typical setup of a gas processing unit with membranes is shown in Figure 5. HISELECT® membranes efficiently remove CO<sub>2</sub> from natural gas over a wide flow rate and concentration range. The membranes demonstrate high selectivity for CO<sub>2</sub>, irrespective of high hydrogen content (HHC) and CO<sub>2</sub> partial pressure. Additionally, strong resistance to unsaturated hydrocarbons, mechanical robustness, and high resistance to hydrogen sulphide (H<sub>2</sub>S) result in low maintenance requirements and a rapid return on investment. Beside applications in natural gas sweetening, HISELECT® membrane technology can also be applied in hybrid solutions with pressure-swing or temperature-swing adsorption units to efficiently remove CO<sub>2</sub> or other gases from process gases.

**Highlights**

- Low CapEx and OpEx with high operational flexibility
- High separation capacity and high selectivity for maximum recovery rates and high purities
- Ability to tailor membrane capacity and selectivity to customer requirements
- High volume efficiency due to optimized packing of hollow fibre membranes
- Production flexibility with wide feed stream condition range and supporting temperatures up to 100 °C and pressures up to 200 bar
- Resistant to CO<sub>2</sub> partial pressure of up to 50 bar
- Robust and stable performance over time under harsh operating conditions, reducing need for overdesign
- Reduced pre-treatment effort due to excellent resistance to heavy hydrocarbons and plasticization
- Mechanical resistance to process fluctuations during operation

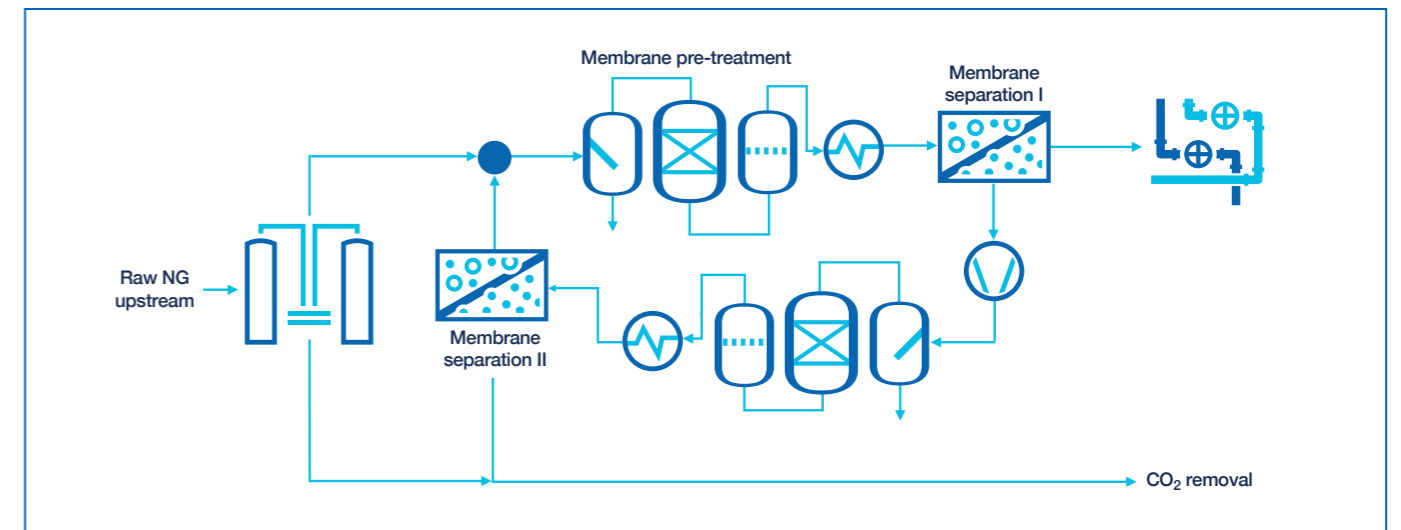

Figure 5: Typical process design of a gas processing unit with HISELECT® for natural gas acid removal



**Rectisol® wash unit**

Linde's Rectisol® wash unit is able to extract sour gas from syngas. The technology uses proven technology that is adjusted to the actual needs and requirements of plant operators. Its application in syngas is indicated in Figure 6. It is flexible with respect to upstream syngas generation as well as gas specification for downstream applications. Rectisol® can either be used for selective removal of CO<sub>2</sub> and sulphur or it can be designed for designated CO<sub>2</sub> capture. In case of selective removal of CO<sub>2</sub> and sulphur, about 99% of the CO<sub>2</sub> can be captured sulphur-free, which means that no additional desulfurization units are required. Rectisol® can be integrated with other Linde gas processing technologies (such as downstream PSA and cryogenic processes). Nominal capacities can vary widely, from small-scale plants (30,000 Nm<sup>3</sup>/h feed gas) up to high one-train capacity plants (2,000,000 Nm<sup>3</sup>/h feed gas).

**Highlights**

- State-of-the-art process
- Used for the treatment of feed gas containing sulphur and CO<sub>2</sub>
- Water- and sulphur-free CO<sub>2</sub> product for further processing
- Enriched H<sub>2</sub>S fraction can be realized within one process
- Easy solvent handling (chemically stable, low cost and readily available on the market)
- Enhanced trace component handling
- Low product losses (H<sub>2</sub> and CO)

**FOR GAS STREAMS WITH MEDIUM TO HIGH CO<sub>2</sub> CONTENT**

**CO<sub>2</sub> PSA**

Linde's pressure swing adsorption (PSA) system is an innovative, efficient and low - CapEx technology for the recovery of CO<sub>2</sub> from process gas streams covering a wide concentration range, such as from process gases including syngas streams and iron and steel production off-gases, as shown in Figure 7.

In the case of syngas, PSA technology is used to recover CO<sub>2</sub> from upstream, high-pressure raw syngas streams or low-pressure off-gas streams generated by SMR or gasification processes. In many cases, PSA technology is a more cost-effective alternative to conventional washing systems due to its lower investment and operating costs.

In the iron and steel industry, PSA technology can be used to efficiently remove CO<sub>2</sub> in direct reduction or blast furnace off-gases. The process removes maximum amounts of CO<sub>2</sub>, yet leaves valuable gas components, such as H<sub>2</sub>, CO, and CH<sub>4</sub> in the gas stream for further

processing.

A CO<sub>2</sub> PSA unit can achieve a product purity of up to 95 vol%, with unit capacities ranging from a few thousand Nm<sup>3</sup>/h to around 300,000 Nm<sup>3</sup>/h.

**Highlights**

- Mature and robust purification technology
- No electricity consumption
- No steam required for regeneration (thereby no additional CO<sub>2</sub> generation). No solvent is applied.
- No negative environmental impact due to the emissions of solvent traces in exhausts or CO<sub>2</sub> product
- No extra cost for solvent makeup and handling
- Low CapEx and OpEx technology

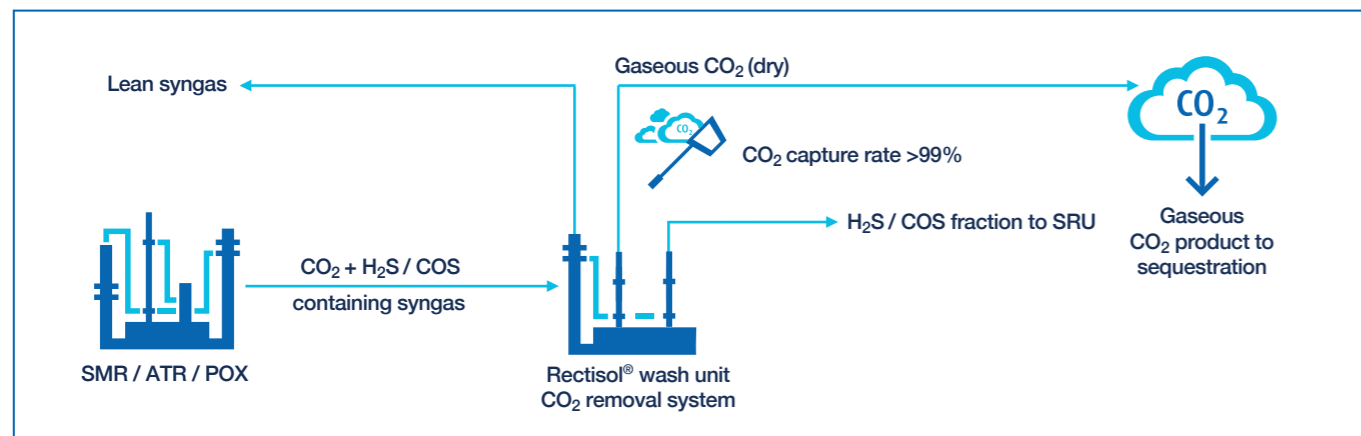

Figure 6: Typical Rectisol® process design for CO<sub>2</sub> capture from syngas

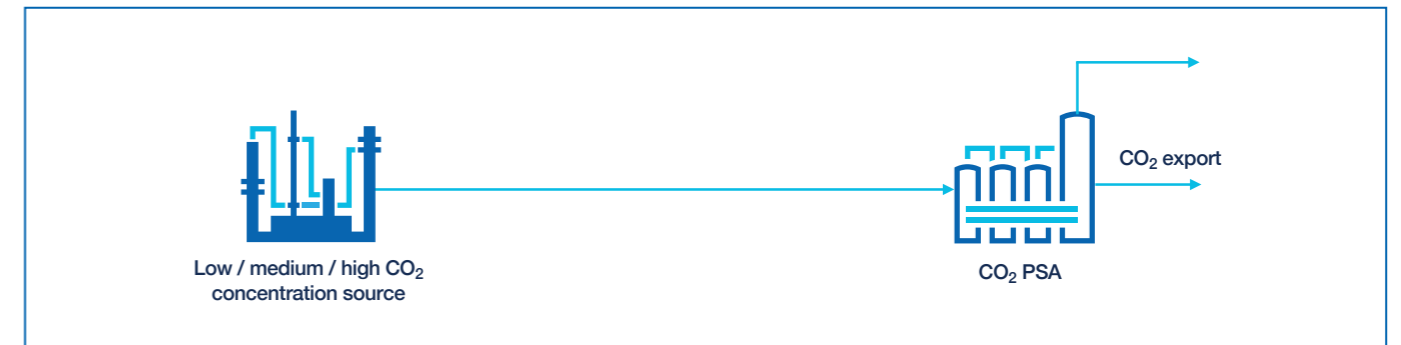

Figure 7: Typical CO<sub>2</sub> PSA process design for efficient capture of CO<sub>2</sub> from process gases



**CO<sub>2</sub> Processing Unit**

Linde's CO<sub>2</sub> Processing Unit (CPU) is applied to purify CO<sub>2</sub> containing gas streams to provide typical CO<sub>2</sub> product specifications for a variety of industrial applications. Typical CPU feed gas streams are CO<sub>2</sub>-rich gases generated from CO<sub>2</sub> capture processes, flue gases from oxy-fuel combustion processes or CO<sub>2</sub>-rich off-gases from chemical plants, such as ammonia, ethylene oxide, methanol or ethanol plants. As shown in Figure 8, an extended toolbox of processes and technologies allows for the removal of different trace components, such as sulphur- or nitrogen-containing compounds, hydrocarbons, heavy metals and air gases.

Linde initially developed and commercialized the CPU technology to treat oxy-fuel flue gases at an oxy-fuel lignite-fired power plant at Schwarze Pumpe, Germany.

More recently, Linde's CPU has been considered for oxy-fuel projects in the cement industry. Mature CO<sub>2</sub> processing technologies in combination with Linde's track record in large-scale gas-treatment plants ensure low-risk EPC projects for clients.

**Highlights**

- Mature and robust purification technology
- Reference plant in Schwarze Pumpe, Germany, for treatment of oxy-fuel flue gases
- Multiple EPC and Linde operation references for production of food-, chemical- and electronics-grade CO<sub>2</sub>
- Standardized and skid-mounted modules as well as large-scale customized, stick-built solutions available

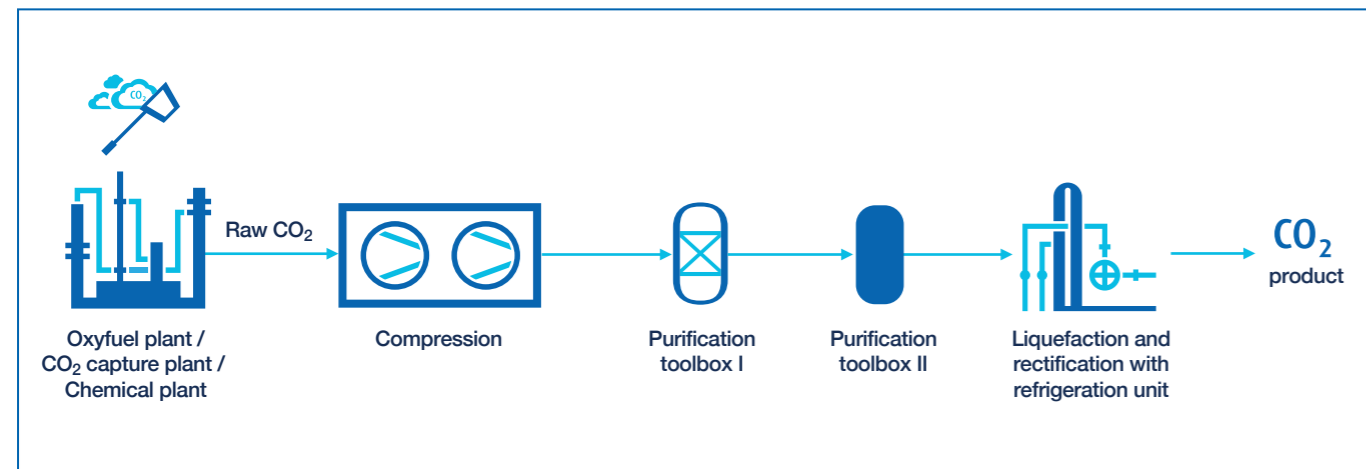

Figure 8: Typical CO<sub>2</sub> Processing Unit (CPU) design

**CO<sub>2</sub> compression/ dehydration**

CO<sub>2</sub> compression and dehydration (see Figure 9) are the most common process units in all CO<sub>2</sub> plants. If the CO<sub>2</sub> purity already meets specification requirements after the CO<sub>2</sub> capture process, the downstream CO<sub>2</sub> treatment usually involves compression and dehydration. It is also a typical process unit for CPU and CO<sub>2</sub> liquefaction plants.

Depending on the plant capacity, different types of compressors can be used, such as piston, screw and turbo compressors. And depending on local costs for utilities, electrical or steam-driven compressors can be employed.

The targeted CO<sub>2</sub> product pressure is defined by the downstream application or distribution concept. Pressures of up to a maximum of 215 bar have been realized. Compressor stations not only compress the main CO<sub>2</sub> feed gas stream, but can also be used to integrate and compress boil-off gases from storage tanks and other CO<sub>2</sub>-rich vents from the plant.

**Highlights**

- Mature and robust technology
- Various options for compressor types
- Multiple references for different scales worldwide

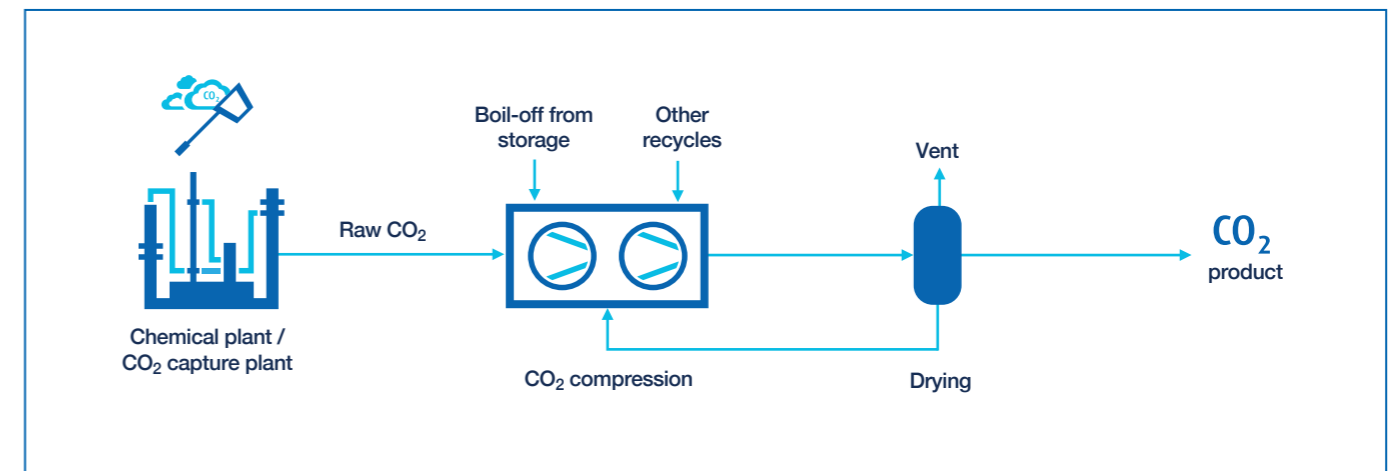

Figure 9: Typical CO<sub>2</sub> compression and drying process design





**CO<sub>2</sub> liquefaction**

CO<sub>2</sub> liquefaction, as shown in Figure 10, can be an additional process step attached to a CO<sub>2</sub> capture and processing plant. For example, when CO<sub>2</sub> is purified by means of cryogenic separation (rectification), CO<sub>2</sub> liquefaction is involved. In addition, CO<sub>2</sub> liquefaction might be required because of the CO<sub>2</sub> logistics concept when transporting it via road trailers, trains or ships. Linde's largest liquefaction plant in operation since 2015 is producing approximately 1,350 tons per day of CO<sub>2</sub>. The CO<sub>2</sub> is used in enhanced methanol and urea production. Additional large-scale plant references can be found

in Norway and the United States for carbon capture and storage (CCS) and food applications, respectively. Depending on local needs, the integration concept, safety considerations and cost efficiency, different refrigerants can be considered for use in the refrigeration unit.

**Highlights**

- Mature and robust technology
- Various options for refrigerants available
- Extended reference list at various product capacities
- Standardized and skid-mounted modules as well as large-scale customized, stick-built solutions available

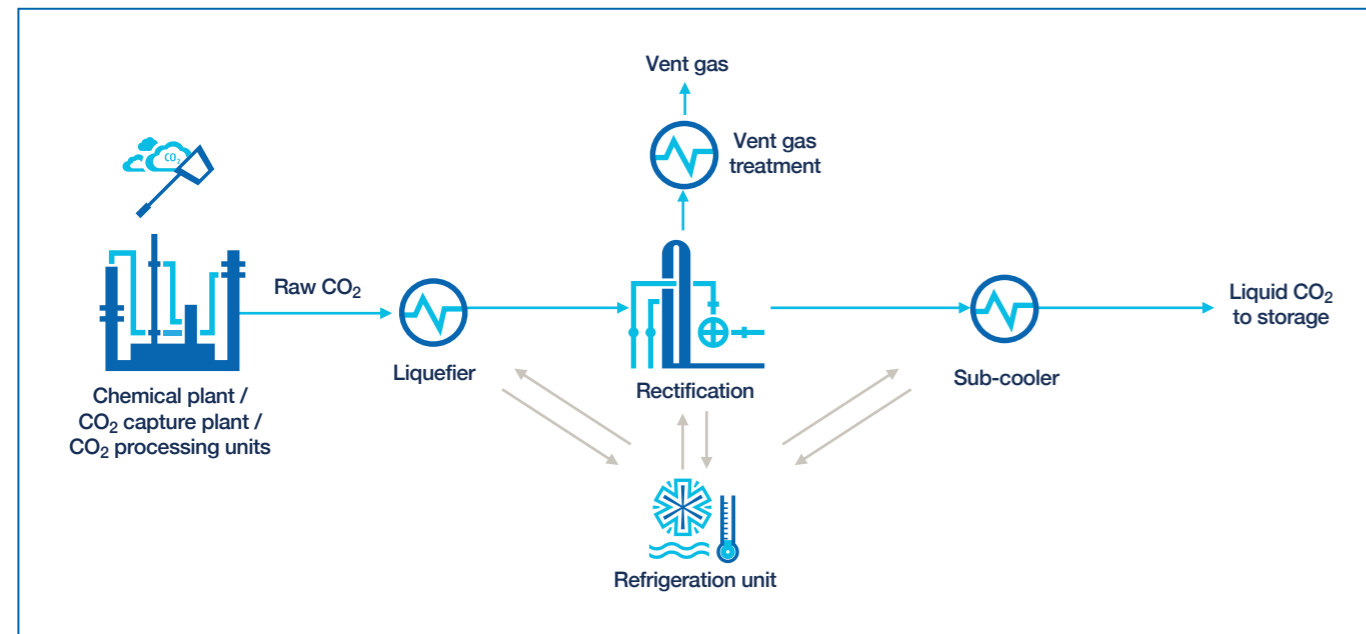

Figure 10: Typical CO<sub>2</sub> liquefaction process design

**CO<sub>2</sub> tank farm and loading stations**

Linde offers state-of-the-art tank farms to store liquid CO<sub>2</sub>. A range of configurations are available. For example, the storage tanks can be spherical or cylindrical (vertical or horizontal). Tank farms can be equipped with boil-off gas re-liquefaction as well as integration of gas return lines. Moreover, an essential component of a tank farm is a loading station. While most tank farms feature trailer

loading stations, Linde has also built train and ship loading stations (see Figure 11). This covers the whole range of potential distribution concepts.

**Highlights**

- Extended reference list at various product capacities
- High degree of standardization and skidded packages to reduce CapEx

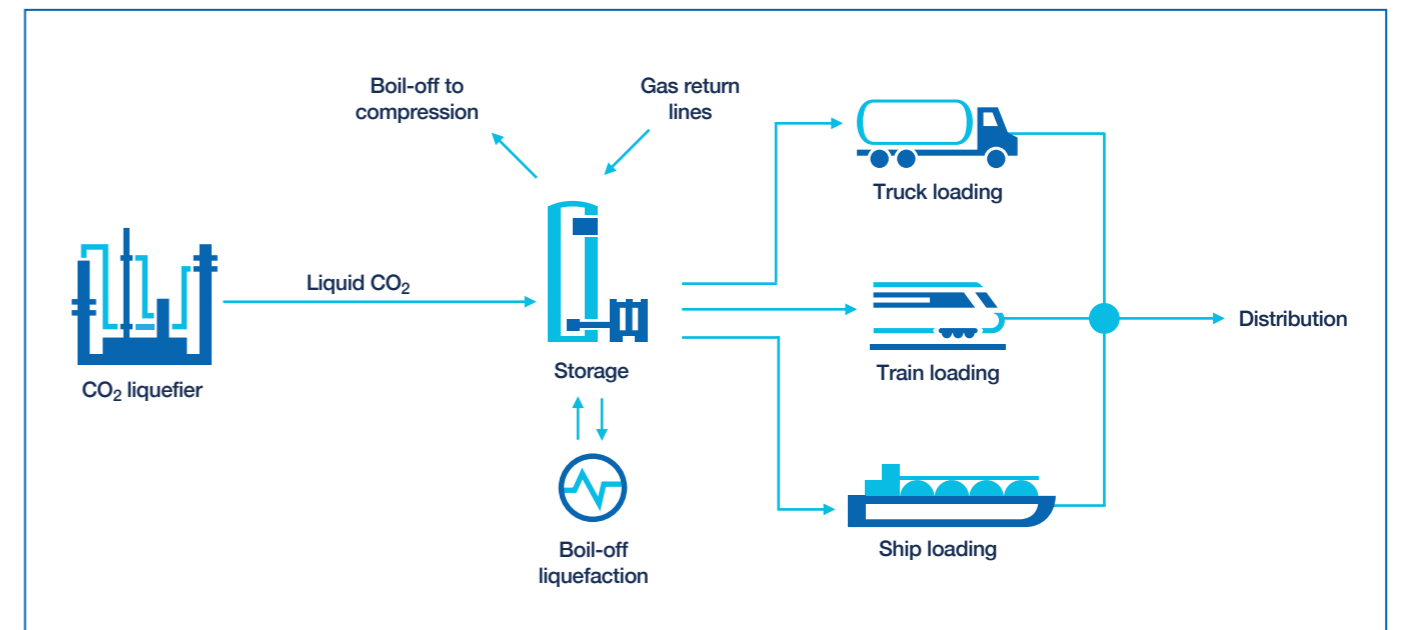

Figure 11: CO<sub>2</sub> tank farm and loading station







**SUMMARY**

The transition to cleaner, carbon-neutral energy, coupled with the growth in decarbonization methods, is one of the most significant technological shifts to happen in modern history. Throughout our 150 years of experience at NOV, we have pioneered innovations that have enabled our customers to safely produce abundant energy while minimizing the environmental impact of their operations. The energy industry depends on our deep expertise and technology to assist in advancing the energy transition toward a more sustainable future.

We have joined the movement and our goal is simple: rejuvenate to improve upon what we already offer, repurpose technology and equipment traditionally used in oil and gas operations, and reposition the skills and knowledge from oil and gas towards the energy transition.

Carbon Capture, Utilization, and Storage (CCUS) is one initiative where our gas processing technologists and process system experts have been able to utilize their core competencies to design a carbon capture system for post-combustion flue gas. Within upstream oil and gas, our Wellstream Processing group is recognized as the global leader in delivering gas processing technologies and process systems. This expertise is cultivated from our 35-year history of executing more than 350 complex gas treatment and conditioning projects in close to 50 countries worldwide.

Last year, we announced the release of our built-for-purpose carbon capture system. This solvent based, post-combustion capture design removes more than 90% of carbon dioxide. The flexibility in the selection of technology and scalability of our solution supports a wide range of applications and industries. We are also involved in strategic partnerships to develop additional carbon capture technologies.

In addition to our carbon capture technology, we design and supply gas dehydration and conditioning systems. Our diverse dehydration portfolio includes triethylene glycol (TEG) units, molecular sieves, and silica gel, and we have executed more than 100 projects. High-energy recovery and low-glycol loss are achieved by our dehydration packages and modules, which are compact, lightweight, and small in footprint. Our CO<sub>2</sub> dehydration systems reduce the water dewpoint, preventing hydrate formation, condensation, and corrosion in the downstream processes. Carbon dioxide (CO<sub>2</sub>) conditioning packages include removing contaminants such as oxygen, H<sub>2</sub>S and mercury, and compression for end use.

**BENEFITS**

NOV is a one-stop-shop, offering capabilities to support throughout the entire value chain. These benefits include:

- Established execution and global supply chain models, featuring local, low-cost fabrication and decreased delivery times
- Experience in standardized system and equipment packages to drive efficiency
- Precision with large-scale projects, resulting in lower engineering design and project management
- Research and development activity to keep customers involved with the latest CCUS technology advancements
- Vast well construction capabilities for geological storage to streamline vendor operations

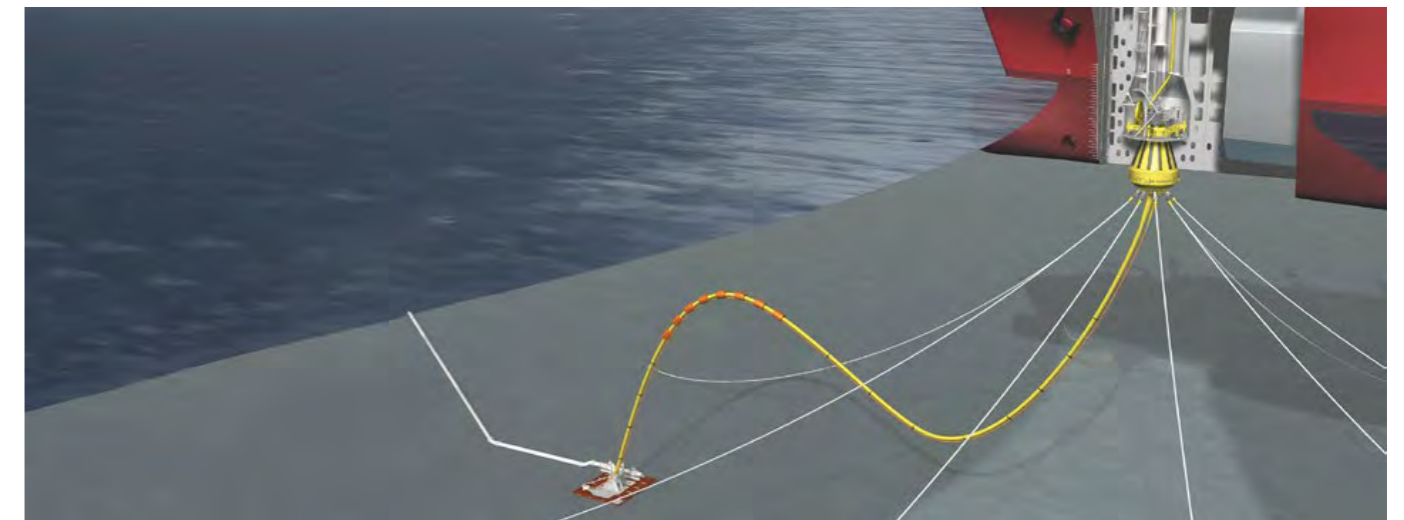

Submerged Turret Loading - An optimal solution for deep water locations, our Submerged Turret Loading (STL) system is designed for shuttling and permanent mooring or continuous operation. Our STL ensures safe and secure injection offshore.

**Carbon Capture Utilization and Storage (CCUS) Offering**

Transferability of our natural gas processing portfolio for CCUS

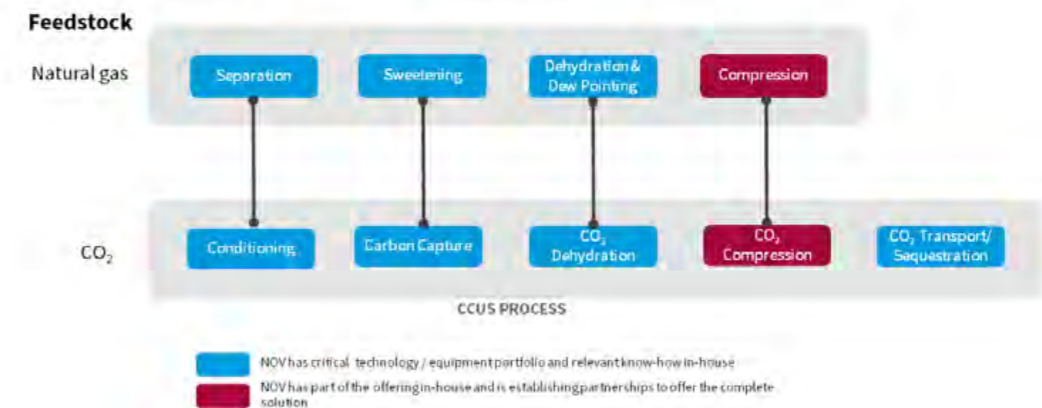

Transferability of our gas processing portfolio - We are the global leader in delivering gas processing technologies and process systems. This expertise transfers into the CCUS value chain and is cultivated from our 35-year history of executing more than 350 complex gas treatment and conditioning projects in close to 50 countries worldwide.



**DESCRIPTION**

Industry-leading solutions for CO<sub>2</sub> projects of any size are also available for transport, offshore offloading, injection, and storage. Our growing suite of automation, control, and monitoring solutions also support safe and reliable operations. A sampling of our solutions across CCUS includes:

**Transportation**

- For more than 80 years, Tuboscope has provided products and services that improve asset performance and maximize useful life. Our TK™-Corrosion control products and pipeline connection systems have successfully been used in CO<sub>2</sub> and carbon capture applications, efficiently transporting waste, preventing severe deterioration of pipeline and downhole tubing due to the corrosive nature of carbon-containing wastewater.
- The proprietary suite of Tube-Kote™ coatings addresses all operating environments, providing superior corrosion protection, deposit mitigation and improved hydraulics. When used with our pipeline connection systems, the result is a continuous coated surface throughout the connection area and improved pipeline integrity and efficiency.
- Our TK-Liner, GRE lined carbon steel pipe, delivers excellent corrosion protection in highly corrosive environments, as well as thermal insulation for downhole tubulars and flowlines.
- For more than 50 years, composite pipe has been used in CO<sub>2</sub> injection lines, high- and low-pressure pipelines, ductwork, WAG systems, and other challenging carbon capture and transportation applications. Our products are ideal for these critical applications due to their ability to handle concentrations of up to 100% CO<sub>2</sub>. Composite solutions bring excellent corrosion resistance without the additional cost of cathodic protections or coatings traditional metallic materials require.
- Our energy efficient horizontal pumping systems are an ideal option to boost CO<sub>2</sub> pressure for pipeline entry. Tying into our variable frequency drive (VFD), users control the speed of the pump to adjust discharge pressure and flow rate, as needed. Additionally, automation, control, and monitoring solutions drive productivity and improve safety and reliability.

**Offshore offloading, injection, and storage**

- We assist customers with offshore CO<sub>2</sub> transfer, from terminal or storage vessel to shuttle vessel, shuttle vessel to storage facilities/well, or from shuttle vessel to storage and injection vessel. Transfer and mooring systems are important to secure vessels and ensure safe and reliable CO<sub>2</sub> injection offshore.
- Our Single Anchor Loading (SAL) and Submerged Swivel and Yoke (SSY) systems are used in shallow waters, while our Submerged Turret Loading (STL) system is used in deep water locations. The SAL system is designed for shuttling operations where continuous injections are not required, also known as batch wise injection. Alternately, the STL is suited for both shuttling and permanent mooring/continuous operation in deeper waters (50 - 2500 m). The SSY is the preferable solution for permanent moored/continuous operation systems in shallow waters (15 - 60 m). Technology choice and individual system complexity levels are also subject to specific seabed, soil, and weather conditions for the given terminal or storage aquifer/reservoir location.
- Our portfolio of dynamic high-pressure unbonded flexible pipes is compatible with CO<sub>2</sub>. Already used in deep waters for CO<sub>2</sub> enhanced oil recovery injection (EOR), our offshore flexible pipes are equally applicable for injection into permanent storage.
- We also develop solutions for safe and efficient vessel integration of our technologies for CO<sub>2</sub> transfer interfaces, which include the Bow Loading System (BLS) and the Stern Discharge System (SDS). These high performing, field proven technologies have been used in the oil and gas industry for decades and are easily converted to CO<sub>2</sub> transfer in all three pressure and temperature levels considered for CO<sub>2</sub> handling.
- Our full suite of drilling technologies offers many solutions for drilling into saline aquifers or depleted oil and gas reservoirs for permanent CO<sub>2</sub> storage. We offer a complete suite of tubulars and bottom hole assembly (BHA) tools, as well as drilling optimization services.

**Research and technology**

We are home to multiple research and technology centres. Two of our facilities are specifically linked to NOV's low carbon initiatives, the Springett Technology Centre located just outside of Houston in Navasota, Texas, and the Flotta facility in Orkney, Scotland located in the heart of the Orkney Net Zero Ecosystem. We can rapidly produce prototypes and test technology for customers with expanding capabilities to support more low carbon

initiatives. Additionally, our lab services for low carbon supports environmental impact research, surveys, atmospheric monitoring, and permits.

As solutions to support decarbonization continue to evolve, NOV will remain at the forefront solving challenges and partnering with customers across the entire CCUS value chain. Please let us know if we can assist with your next project by emailing [marketing@nov.com](mailto:marketing@nov.com).

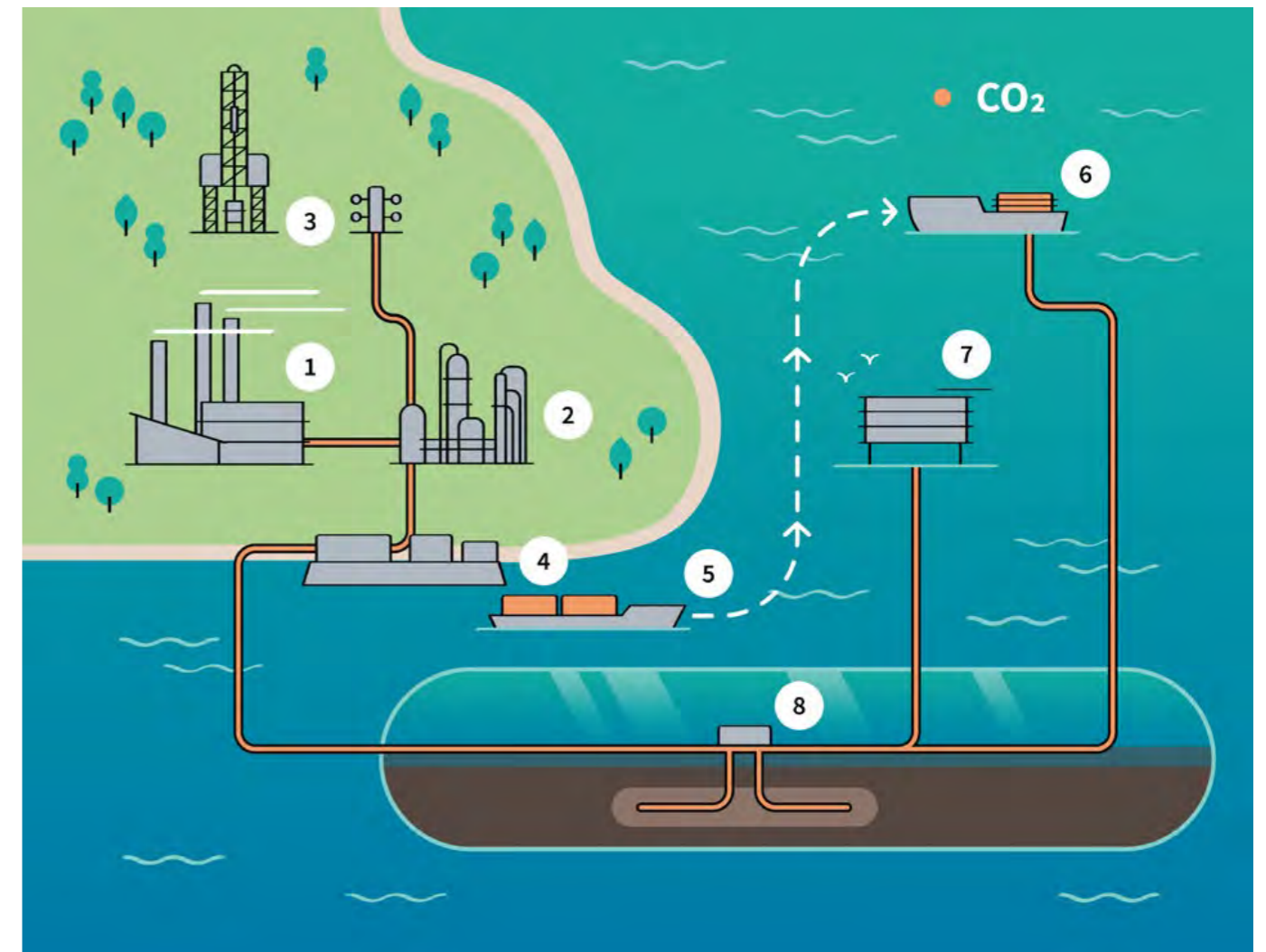

NOV technology supports the entire CCUS value chain. (1) Emission source (2) Carbon capture system (3) Onshore CO<sub>2</sub> injection well (4) Terminal for offshore CO<sub>2</sub> transportation (5) Transportation vessel (6) Vessel for offshore offloading and CO<sub>2</sub> injection (7) Re-purposed offshore platform for CO<sub>2</sub> injection (8) Offshore injection well for CO<sub>2</sub>





## 50+ Carbon Capture and Storage Projects

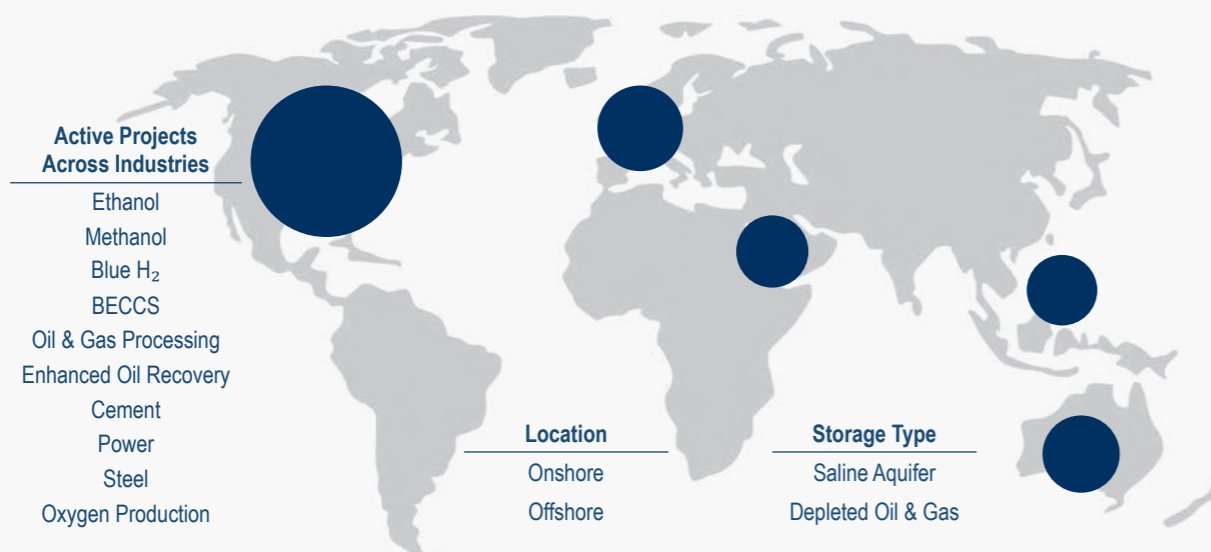

### SUMMARY

Carbon capture and storage (CCS) is a critical component of advancing decarbonization and achieving the Paris Agreement’s climate change goals. **As a technology leader in CCS and in the development of decarbonization and alternative energy solutions, Schlumberger is actively progressing CCS technologies and business models to enable widespread adoption of CCS.**

What Schlumberger brings to achieve these goals is more than 90 years of experience in characterizing and modelling underground rock formations and in designing and constructing wells. Schlumberger’s acquisition of Cameron in 2016 added a rich legacy in gas processing and pressure control equipment. For decades, we have been deploying digital tools and sophisticated sensors to improve operations, minimize risk, and monitor assets, including the use of automation, artificial intelligence, and comprehensive data management.

We applied this know-how to become an early technology leader in carbon capture for enhanced oil recovery (EOR) applications. Thirty-five years ago, we helped build the world’s first commercial CO<sub>2</sub> plant at the SACROC Field in West Texas.

For over two decades, Schlumberger has participated in more than 50 CCS projects around the globe, in different geological contexts and for various industry sectors. This hands-on experience, combined with our technology leadership, gives us unique insights into the varied

complexities posed by CO<sub>2</sub> sequestration. In order to overcome these challenges, we have united the diverse disciplines of geoscience and engineering to develop innovative, integrated end-to-end processes that enable us to deliver sequestration projects anywhere in the world.

Recently, Schlumberger has explored creating strategic partnerships with emitters to assess, develop, and operate projects spanning the entire CCS value chain, from capture to storage. The scope of collaboration goes beyond subsurface requirements and includes project economics, technology selection, business models, and permitting for a CCS project. By partnering with leaders in a range of strategic sectors, we are demonstrating viable and scalable CCS solutions across a wide range of industries. For example, we are exploring with Lafarge Holcim the feasibility of capturing carbon emissions from cement plants. Schlumberger is also collaborating with Chevron Corporation, Microsoft, and Clean Energy Systems on a bioenergy with carbon capture sequestration (BECCS) project in Mendota, California.

In addition to our deep expertise, technological leadership, and experience in creating viable CCS solutions, Schlumberger is uniquely positioned to help scale up the manufacturing of CCS technologies. We are leveraging our more than 80 technology centres and extensive manufacturing capabilities around the world to industrialize and deploy CCS technologies globally.

Schlumberger is developing, adapting, and applying innovative technologies in scalable business models to provide our customers and partners with economically viable solutions across the CCS value chain. In this “State of the Art: CCS Technologies 2022” report, we highlight some of the advanced technologies in our portfolio that significantly support the CCS industry today, organized into three sections:

- Capture, Gas Processing, and Transport
- Storage Selection, Design, and Construction
- Storage Monitoring, Verification, and Reporting.

### Capture, Gas Processing, And Transport

#### Highlighted Technologies and Services in our Portfolio

##### Capture and gas processing technologies

- Symmetry process software platform, available in our DELFI cognitive E&P environment
- CYNARA acid gas removal membrane system
- Amine gas treating systems
- SULFATREAT H<sub>2</sub>S removal adsorbent
- Process Live data-enriched performance service

##### Transport technologies

- OLGA dynamic multiphase flow simulator, available in our DELFI environment
- Horizontal pumping systems for pressure boosting during transport
- Low-emission valves

Our Symmetry process software platform enables the design and simulation of CO<sub>2</sub> capture process workflows in one environment that integrates pipelines, capture and compression facilities, and safety models while ensuring consistent thermodynamics and fluid characterization across the full system. **The use of the Symmetry platform in several CCS projects in Canada was key in rightsizing the process design and accurately modelling the phase envelope and control system integration.** For each project, the Symmetry platform identified operational improvements and minimized health, safety, and environment (HSE) risks.

The choice of capture technology depends on the purity of the CO<sub>2</sub> stream and whether capture is pre-, post-, or oxy-combustion. Comprehensive evaluation of these options in the Symmetry platform can achieve the optimum system in terms of both technical and economic feasibility.

Once CO<sub>2</sub> is captured, a variety of treatment technologies may be needed. Schlumberger offers both membrane systems and amine gas treatment systems in a range of designs and sizes to meet specific project requirements. The CYNARA acid gas removal membrane system works to separate CO<sub>2</sub> and H<sub>2</sub>S from natural gas via preferential permeation of the smaller acid gas molecules. The separated CO<sub>2</sub> can be transported and sequestered at a selected storage site.

**Monitoring valves and gas membrane systems with Process Live data-enriched performance service provides real-time status reports of performance and automates event detection.** These insights mitigate the risk of downtime and reduce inventory costs. Using Process Live service, we currently are providing uptime assurance and treatment optimization of 4.92 Mtpa CO<sub>2</sub>.

The OLGA dynamic multiphase flow simulator models and simulates the transportation of CO<sub>2</sub> from capture to injection. This enables a comprehensive understanding of optimal operating conditions to ensure that CO<sub>2</sub> remains in phase.

When transporting CO<sub>2</sub> between facilities, horizontal pumping systems provide the necessary pressure boost to maintain it in a fluid state. **Schlumberger has more than 15 years of experience with a wide variety of CO<sub>2</sub> transport operations. We understand how the selection of appropriate seals, valves, production chemicals, and maintenance schedules plays a critical role in equipment longevity and operational safety.**

To date, Schlumberger has installed thousands of industrial valves in various CO<sub>2</sub> and gas processing applications. In addition to enabling remote operation, these low-emission valves incorporate custom seals that reinforce their operational integrity. Some of the valves in this portfolio are manufactured to minimize leaks across the life of the valve.

To reduce maintenance downtime, our production chemistry technologies address specific problems of corrosion and hydrate formation.





## Storage Selection, Design, And Construction

Schlumberger has developed a wide range of risk assessment methods for screening geological formations and for identifying the most suitable site by conducting site characterization assessments. This in-depth assessment and evaluation of key criteria (such as storage capacity, injectivity, and containment) enables our customers to minimize cost while ensuring secure long-term CO<sub>2</sub> storage.

Integral to our involvement in CCS projects is our more than 35 years of petrotechnical software development experience paired with deep domain knowledge. End-to-end digital technologies harness this experience and expertise to drive workflows that screen, rank, design, model, simulate, and analyse every phase of the CCS project's life cycle.

By conducting the workflows within the DELFI cognitive exploration and production (E&P) environment, we leverage artificial intelligence and machine learning. For example, the interpretation workflows used to build a model of a storage site benefits from a 10× to 20× acceleration in workflow time by employing machine learning. Reservoir simulations benefit from high performance computing capabilities that reduce simulation time so that the engineers can focus on analysing results and exploring the full uncertainty space. **The DELFI environment was recently selected by the Northern Lights joint venture between Equinor, Shell, and TotalEnergies to streamline subsurface workflows and longer-term modelling and surveillance of CO<sub>2</sub> sequestration.**

Once the storage site has been selected and the project commissioned, we leverage our decades of expertise in well construction to optimize construction operations, including the selection and installation of monitoring methods.

Well integrity has been identified as the biggest risk contributing to leakage of CO<sub>2</sub> from underground carbon storage sites. **EverCRETE CO<sub>2</sub>-resistant cement system enables more efficient and secure underground storage compared with ordinary portland cement.** Whereas ordinary Portland cement is not resistant to CO<sub>2</sub> fluids and can degrade in a few weeks or less, the reaction between CO<sub>2</sub> fluids and the EverCRETE system results in a stable structure after two weeks, and mechanical and chemical properties are no longer affected.

Schlumberger designs and manufactures specialized wellheads, seals, and gate valves for achieving permanent underground sequestration of CO<sub>2</sub>. Our corrosion-resistant equipment is constructed with customized coating to withstand aggressive environments under any temperature conditions. The metal and elastomer seals used in these wellhead systems are proved to endure demanding pressures, temperatures, and corrosive environments.

## Storage Monitoring, Verification, And Reporting

Securing CO<sub>2</sub> storage and containment over long periods of time requires properly monitoring the CO<sub>2</sub> plume and integrity of the wells. A cost-effective combination of sensors and monitoring protocols can deliver optimum performance control and risk management in compliance with regulatory requirements.

Monitoring strategy design must address

- what is to be monitored
- what are the property variations
- how will those variations occur.

For a monitoring strategy to meet its objectives in terms of assurance, verification, and cost optimization, a holistic solution design and modelling workflow is required.

Critical to the success of the monitoring strategy design is the incorporation of dynamic geomechanical modelling, such as using our ECLIPSE, INTERSECT, and VISAGE simulators, for predicting subsurface behaviour and identifying the key parameters and their uncertainties. This informs the design and planning of appropriate geophysical measurements. A successful monitoring strategy is able to history match the dynamic modelling against field observation to identify anomalies and update the subsurface model, monitoring strategy, and risk model accordingly in real time.

Updating models requires timely measurements, for which a primary objective is to minimize data acquisition time and effort without adversely affecting interpretation quality. Our versatile and highly sensitive distributed fibre-optic sensing technology plays a significant role in achieving this balance by providing continuous data in both time and space. **Optiq Schlumberger fiber-optic solutions**

**bring multidomain distributed sensing capabilities to CCS projects for significant efficiency improvements in time-lapse reservoir monitoring through permanent fibre installation or temporarily deployed fibre wireline cables.**

In a 2016 project with the US Department of Energy and Archer Daniels Midland Company (ADM), we installed modular intelligent completion equipment and Optiq solutions to enable real-time monitoring and control of the subsurface storage. Together, we captured from ADM's ethanol facility more than 2.5 Mt CO<sub>2</sub> over a period of three years.

## Highlighted Technologies and Services in our Portfolio

*Site selection and design digital tools, available in our DELFI cognitive E&P environment*

- OLGA dynamic multiphase flow simulator
- Petrel E&P software platform
- ECLIPSE industry reference reservoir simulator
- INTERSECT high-resolution reservoir simulator
- VISAGE finite-element geomechanics simulator
- Symmetry process software platform, available in our DELFI environment

## Formation evaluation technologies

- Litho Scanner high-definition spectroscopy and laboratory services for X-ray diffraction, X-ray fluorescence, and Fourier transform infrared spectroscopy
- MR Scanner expert magnetic resonance and CMR-MagniPHI high-definition NMR service; triple-combo measurements for porosity, permeability, and capillary pressure; and laboratory services for routine and special core analysis, tight rock analysis, and mercury-injection capillary pressure measurement
- FMI-HD high-definition formation microimager, Quanta Geo photorealistic reservoir geology service, and laboratory services for whole core description, core fracture description, and goniometry
- Sonic Scanner acoustic scanning platform, MDT modular formation dynamics tester minifrac, XL-Rock large-volume rotary sidewall coring service, and laboratory services for unconfined compressive strength, triaxial stress testing, and pore volume compressibility
- MDT modular formation dynamics tester, Ora intelligent wireline formation testing platform, and laboratory

services for water analysis

- PressureXpress reservoir pressure-while-logging service
- CoreFlow digital rock and fluid analytics services
- High-resolution well testing services

## Well construction technologies

- DrillPlan coherent well construction planning solution
- EverCRETE CO<sub>2</sub>-resistant cement system
- Wellhead equipment: compact wellheads, monoblock Christmas trees, coated FLS extreme-service API 6A slab-style gate valves, elastomer seals, metal-to-metal seals, MRD recessed-bore metal-to-metal seals

## Well integrity technologies

- Wellbarrier well integrity life cycle solution
- Isolation Scanner cement evaluation service
- PS Platform production services platform multifinger imaging tool (PMIT)
- Slim cement mapping tool (SCMT)
- UCI ultrasonic casing imager, USI ultrasonic imager, and PowerEcho and PowerFlex annular barrier evaluation services
- EM Pipe Scanner electromagnetic casing inspection tool

## Monitoring, verification and reporting technologies

- Optiq Schlumberger fiber-optic solutions
- Pulsar multifunction pulsed neutron service and CHFR cased hole formation resistivity tool
- Optiq StreamLINE polymer-locked fiber-optic wireline conveyance
- Permanent gauges and pressure falloff (PFO) testing
- Isolation Scanner cement evaluation service and UCI ultrasonic casing imager

CHFR, CMR-MagniPHI, CoreFlow, CYNARA, DELFI, DrillPlan, ECLIPSE, EM Pipe Scanner, EverCRETE, FLS, FMI-HD, INTERSECT, Isolation Scanner, Litho Scanner, MDT, MRD, MR Scanner, OLGA, Optiq, Optiq Seismic, Optiq StreamLINE, Ora, Petrel, PowerEcho, PowerFlex, PressureXpress, Process Live, PS Platform, Pulsar, Quanta Geo, Sonic Scanner, Symmetry, SULFATREAT, UCI, USI, VISAGE, Wellbarrier, WellWatcher PS3, and XL-Rock are marks of Schlumberger or a Schlumberger company.





**SUMMARY**

From factory automation to logistics automation and process automation – SICK drives industries with sensors. As a technology and market leader, SICK provides sensors and application solutions that create the perfect basis for controlling processes securely and efficiently, protecting individuals from accidents, and preventing damage to the environment.

Founded in 1946 by Dr.-Ing. h. c. Erwin Sick, the company with headquarters in Waldkirch, Germany ranks among the technological market leaders. With more than 50 subsidiaries and equity investments as well as numerous agencies, SICK maintains a presence all around the globe. In the 2020 fiscal year, SICK had more than 10,000 employees worldwide and a group revenue of around EUR 1.7 billion.

**Sensor Intelligence. For all requirements.**

When movement becomes collaboration, when industrial systems have to be flexible, and when clean solutions are the key, then customer can certainly benefit from SICK’s many years of experience. As an innovation leader and pioneer in the development of groundbreaking sensor technology, we offer solutions that are already up to the challenges of the future today. With intelligent sensor technology that collects data and evaluates it in real time, adapts to its environment and communicates in the network.

**Process Automation**

SICK’s Process Automation division offers sensors and tailored system solutions as well as services for analysis and process measurement technology. When measuring emissions, they monitor the legally prescribed gas components, accurately record dust and particle emissions and measure volume throughput. The ultrasonic technology by SICK is one of the leaders in the precise flow measurement of natural gas in the pipeline distribution network as well as for process gases and steam. SICK’s measurement technology solutions make a valuable contribution to resource-saving plant control in the primary industries.

**Sensor solutions for CCUS**

SICK already has solutions to support the complete CCUS value chain, when it comes to continuous gas analysis or CO<sub>2</sub> flow metering.

**BENEFITS**

- **CO<sub>2</sub> reporting and accounting.** Flow metering will become necessary for fiscal purposes, custody transfer and compliance with future regulatory measurements. SICK provides solid experience from thousands of custody transfer applications with natural gas. This experience can be transferred for each step of the CCUS value chain to ensure accurate flow measurement and precise reporting.
- **Process efficiency.** Carbon capture processes require a high degree of efficiency to improve their economic and environmental attractiveness. The measurement of CO<sub>2</sub> content and the remaining components after the capture process is essential for control and optimization purposes. SICK has more than 10 years of experience with pilot installations.
- **Quality control.** Regardless of the destination of the captured CO<sub>2</sub> (storage or utilization), it is important to control the quality of the gas and possible impurities that can have a negative influence on the later steps of the CCUS network and ensure protection of the environment.
- **SICK LifeTime Services.** SICK LifeTime Services is a comprehensive set of high-quality services provided to support the entire life cycle of products and applications from plant walk-through to upgrades. LifeTime Services range from product-independent consulting to traditional product services.

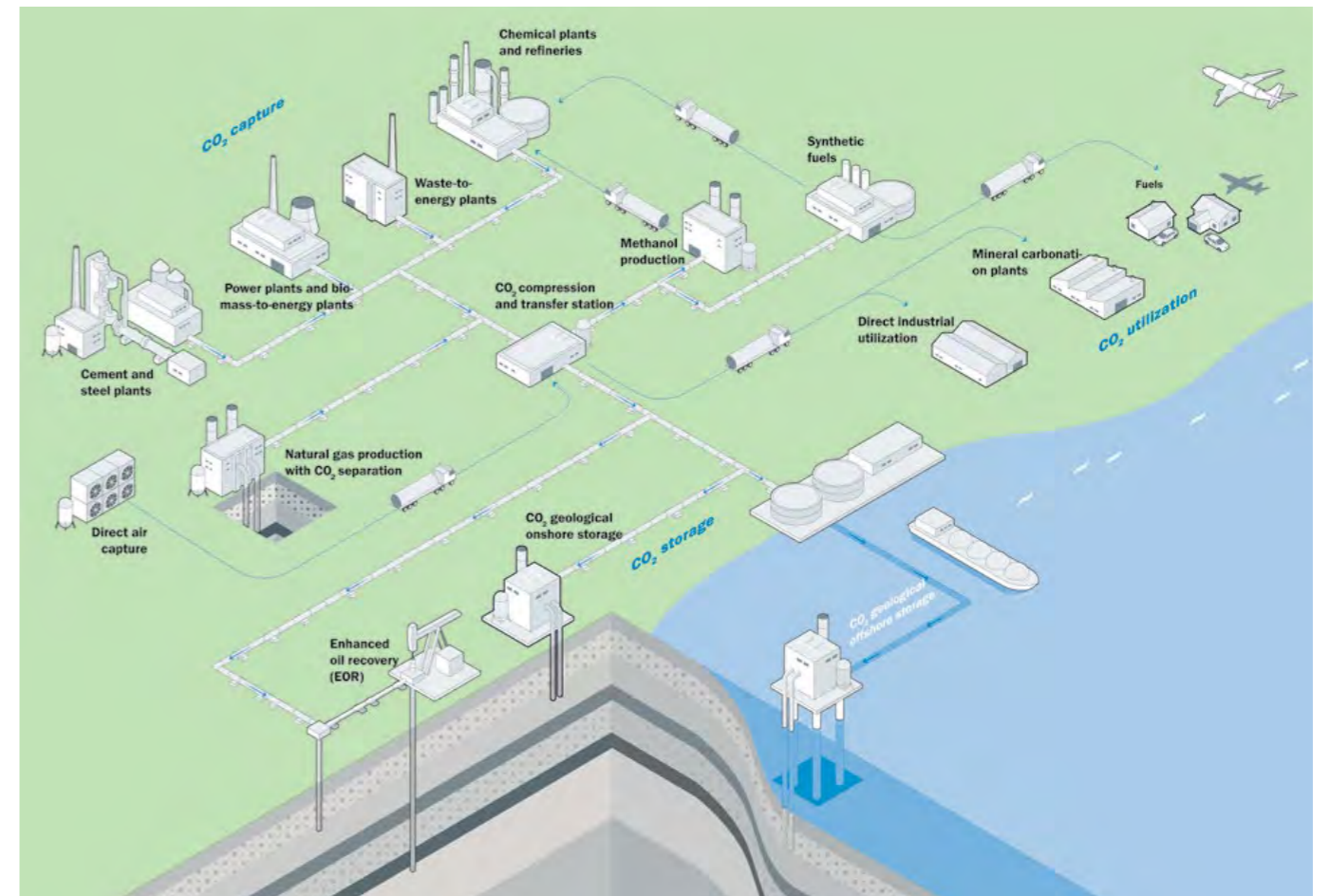



**DESCRIPTION**

**Continuous gas analysers for quality measurement and reporting**

Carbon capture processes produce a highly concentrated gas with more than 90% CO<sub>2</sub> by volume. On the other hand, there are the low carbon emissions to the environment, which have to be reported for taxation purposes. The gas mixtures contain other components that can be considered impurities, and which can be corrosive, and either have an influence on downstream process steps or are harmful to the environment.

To control and optimize the efficiency of processes and emissions along the CCUS value chain, SICK continuous gas analysers accurately measure the concentrations in CO<sub>2</sub> and other components in the gas mixture. Together with SICK's precise gas flow measurement, a true mass flow output is also available. Such measurements are essential prior to transportation, storage or utilization of CO<sub>2</sub>.

Depending on the application, SICK can offer different measuring technologies, including:

- In-situ gas analysers accurately measuring CO<sub>2</sub> directly in the gas flow without gas sampling. The reliability, precision and short response time offer key advantages for efficient process control.
- Extractive analysers from SICK ensure continuous monitoring of multiple components simultaneously such as CO<sub>2</sub>, H<sub>2</sub>O, HCl, SO<sub>2</sub>, CO, NO<sub>x</sub>, NH<sub>3</sub> and O<sub>2</sub> with high accuracy to control and optimize the

CCUS processes. The most suitable analyser can be selected depending on the application, the measuring conditions, and the requested measuring parameters.

**Gas flow measurement for transfer and process applications**

Carbon dioxide can be captured from different emission sources and then collected and transported via pipelines or ships for further handling steps such as storage or utilization. Gas flow measurements are necessary at each transfer point to control the quantity of captured CO<sub>2</sub> or the volume stored or transferred.

Accurate gas metering allows for precise accounting to companies or calculation of CO<sub>2</sub> taxes and credits based on regulations. With our experience in custody transfer applications for natural gas which can be easily transferred to CO<sub>2</sub> and our highly reliable ultrasonic gas flow meters, SICK provides the precise data required to operate the CCUS value chain. The FLOWSIC600/-XT gas flow meters deliver optimal measurement performance and provide the highest rated gas metering accuracy. Thanks to PowerIn Technology™, the FLOWSIC600-XT also ensures that measurements continue to be taken and data is stored even in the event of a power failure. The rugged design provides both the fault-free and maintenance free systems. Due to the direct path layout, the signals are not reflected inside the device and are thus not affected by contamination. This results in long-term system stability and accuracy.

**Reliable turnkey solution for CO<sub>2</sub> metering**

The FLOWSKID flow metering system is a full gas flow metering system. It is provided by SICK as a turnkey solution for transfer applications. The system is flexible in design and provides highly accurate measurement data. With FLOWSIC600 or FLOWSIC600-XT gas flow meters as the heart of the metering skid, system reliability can be assured. The metering skid can be customized with instrumentation including gas analysers, gas chromatographs, and supervisory computers – system solutions made by SICK! It is manufactured according to ISO standards and is of the highest quality in line with the latest DIN, ANSI, and ASME standards. This means the system will fulfil local regulations and requirements.

**Space and protection for measurement and analysis technology**

Container solutions are primarily used to protect the installed analyser systems from extreme ambient conditions such as heat, cold, dust, wind, earthquakes and corrosive or explosive atmospheres. They also offer advantages for transport as well as on-site installation and maintenance. At the factory, everything is coordinated and pre-installed in the container in a clear manner. Each container can be equipped to fit individual customer requirements. The installation of transformers and UPS, extinguishing, climate and gas warning systems is possible, as is the implementation of sample point switching or complex redundancy and signal concepts.





# GET IN TOUCH

To find out more about the Global CCS Institute including Membership and our Consultancy services, visit [globalccsinstitute.com](https://globalccsinstitute.com) or contact us.

---

## AMERICAS

Washington DC, United States  
[americasoffice@globalccsinstitute.com](mailto:americasoffice@globalccsinstitute.com)

## AUSTRALIA

Melbourne, Australia  
[info@globalccsinstitute.com](mailto:info@globalccsinstitute.com)

## CHINA

Beijing, China  
[chinaoffice@globalccsinstitute.com](mailto:chinaoffice@globalccsinstitute.com)

## EUROPE

Brussels, Belgium  
[europeoffice@globalccsinstitute.com](mailto:europeoffice@globalccsinstitute.com)

## JAPAN

Tokyo, Japan  
[japanoffice@globalccsinstitute.com](mailto:japanoffice@globalccsinstitute.com)

## MIDDLE EAST AND NORTH AFRICA

Abu Dhabi, United Arab Emirates  
[menaregion@globalccsinstitute.com](mailto:menaregion@globalccsinstitute.com)

## UNITED KINGDOM

London, United Kingdom  
[ukoffice@globalccsinstitute.com](mailto:ukoffice@globalccsinstitute.com)